

# U.S. Navy Diving Manual, 1943

---

In the collection of the  
U.S. Naval Undersea Museum

NUM.2019.012.048



---

---

# DIVING MANUAL

1943



TECH  
VM981  
.U8  
1943

NAVY DEPARTMENT  
BUREAU OF SHIPS

---

---

*Engineer  
Class 17  
1944*

416

~~2097~~

627.72  
U585d  
1943

NAVY DEPARTMENT  
BUREAU OF SHIPS

# DIVING MANUAL

## 1943

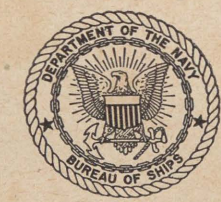

UNITED STATES  
GOVERNMENT PRINTING OFFICE  
WASHINGTON : 1943

# DIVING MANUAL

## TABLE OF CONTENTS

	Page
I. Foreword.....	VII
Chapter I. Development of diving and training of Navy divers.....	1
Chapter II. Physical qualifications of divers.....	10
Chapter III. Navy standard diving outfits.....	15
Chapter IV. Description of Navy standard diving gear.....	18
Chapter V. Shallow water diving apparatus.....	96
Chapter VI. Care, survey, and requisitioning of diving gear.....	104
Chapter VII. Physics of diving.....	123
Chapter VIII. Diving—Planning and arranging.....	128
Chapter IX. Diving—Diver's air supply (normal air).....	136
Chapter X.—Diving—Dressing the diver.....	148
Chapter XI. Diving—The descent.....	151
Chapter XII. Diving—Tending the diver.....	153
Chapter XIII. Diving—Working on the bottom.....	157
Chapter XIV. Diving—The ascent.....	167
Chapter XV. Diving—Diving with the helmet only and shallow-water diving.....	176
Chapter XVI. Diving—Compressed-air illness.....	180
Chapter XVII. Diving—Diving accidents.....	190
Chapter XVIII. Diving—Deeper diving by use of oxy-helium mixture.....	199
Chapter XIX. Diving—Salvage vessels, and special gear.....	236
Chapter XX. Diving—Glossary of terms.....	255
Chapter XXI. Diving—Index.....	260

## LIST OF ILLUSTRATIONS

Plate 1. Section of first floor of Experimental Diving Unit showing diver's recompression chamber (on left) and diving water tank (in background).....	4
Plate 2:	
(1) Diver entering diving water tank, diving school.....	5
(2) Diver in water diving tank sawing through a section of steel piping.....	5
Plate 3:	
(1) Lecture on circuits of various above water and under-water electrical tools and equipment.....	6
(2) Dressing student diver preparatory to descent in river.....	6
(3) Student diver descending in river from diving-school boat <i>Cirilley</i> .....	6
Plate 4:	
(1) Diving school—Diving water tank—Observing the diver in tank and regulating the pressure to correspond with water pressures at desired depths.....	7
(2) Diving school recompression chamber—Recompressing and decompressing the diver.....	7

	Page
Plate 5. Diving school training:	
(1) Training in above water burning as a prelude to under-water cutting.....	8
(2) Diving suit repair work.....	8
(3) Sample of flanges fitted under water by student divers.....	8
Plate 6. Diver completely dressed: Attendant with telephone.....	19
Plate 7. Diver partly dressed—Front view.....	20
Plate 8. Diver partly dressed—Back view.....	21
Plate 9. Diver partly dressed—Showing underwear.....	22
Plate 10. Tool bag.....	23
Plate 11. Diver's weighted belt.....	18
Plate 12. Boxes, tin, for piston leathers and for spare parts.....	23
Plate 13. Buoys, cork.....	24
Plate 14. Standard rubber-covered combination telephone and life-line cable.....	26
Plate 15. Diving outfit chest—Inside view.....	27
Plate 16. Diving outfit chest—Front view.....	27
Plate 17. Helmet chest—Inside view showing cradles.....	28
Plate 18. Helmet chest—Front view.....	28
Plate 19. Helmet cushion, cuff expanders, rubber tubing, and rubber wrist bands.....	30
Plate 20. Standard diving dress, with cuffs attached—Front view.....	31
Plate 21. Standard cuffs for Navy diving dress.....	32
Plate 22. Standard diving dress, with gloves attached—Front view.....	33
Plate 23. Standard divers' and tenders' glove.....	34
Plate 24. Diving helmet, Mark V, Mod. I.—Front view.....	35
Plate 24A. Diving helmet, Mark V, Mod. I.—Side view.....	35
Plate 25. Helmet lock.....	37
Plate 25A. Welding lens and frame, helmet.....	38
Plate 26. Helmet, nonreturn air valve.....	39
Plate 27. Helmet, air-regulating escape valve assembled.....	40
Plate 27A. Helmet, air regulating escape valve, disassembled.....	41
Plate 28. Grooving tool for installing air-regulating escape valve.....	43
Plate 29. Diving air hose.....	44
Plate 30. Diving air hose couplings and clamps.....	46
Plate 31. Diving air hose special fittings.....	47
Plate 32. Diving air hose double female coupling.....	47
Plate 33. Diver's knife.....	48
Plate 34. Diving ladder.....	50
Plate 35. Diving ladder details.....	51
Plate 36.	
Plate 37.	
Plate 38.	
Plate 39.	
Plate 40.	
Plate 41.	
Plate 42. Underwater visibility—Studded steel plates as they appear to	
Plate 43.     the eye under water in unfiltered and filtered light.....	53-59
Plate 44.	
Plate 45.	
Plate 46.	
Plate 47.	
Plate 48.	
Plate 49.	

	Page
Plate 50. Diving light, Westinghouse Lamp Co. type—Assembled.....	62
Plate 51. Diving light, Westinghouse Lamp Co. type—Disassembled.....	62
Plate 52. Diving light, A. J. Morse & Co. type—Assembled.....	63
Plate 53. Diving light, A. J. Morse & Co. type—Disassembled.....	63
Plate 54. Diver's control valve and air manifold.....	66
Plate 55. Navy standard diving air pump, Mark III, assembled—Front view.....	66
Plate 56. Navy standard diving air pump, Mark III, assembled—Back view.....	67
Plate 57. Navy standard diving air pump, Mark III, with top raised and front cover removed.....	68
Plate 58. Navy standard diving air pump, Mark III, arranged to supply air for two divers.....	68
Plate 59. Navy standard diving air pump, Mark III, removed from case.....	69
Plate 60. Navy standard diving air pump, Mark III, removed from case and showing pump wheels, handles, oil separators, and enlarged view of pump gages.....	70
Plate 61. Navy standard diving pump piston.....	71
Plate 62. Navy standard diving pump piston assembling tool.....	74
Plate 63. Oil separator—Assembled.....	75
Plate 64. Oil separator—Disassembled.....	76
Plate 65. Navy standard diving shoes.....	77
Plate 66. Decompression stage, small, front and plan view.....	78
Plate 67. Decompression stage, large, front view.....	79
Plate 68. Decompression stage, large, plan view.....	80
Plate 69. Diver's stool.....	81
Plate 70. Diving telephone, batteryless type.....	83
Plate 70-A. Diving telephone, batteryless type—Control box.....	83
Plate 71. Diving telephone, amplifier type.....	86
Plate 71-A. Diving telephone coupling, double female connection—Assembled.....	87
Plate 71-B. Diving telephone coupling, double female connection—Disassembled.....	87
Plate 71-C. Diving telephone connection, male (jack plug housing)—Assembled.....	88
Plate 71-D. Diving telephone connection, male (jack plug housing)—Disassembled.....	88
Plate 71-E. Diving telephone coupling, for helmet gooseneck (female connection)—Assembled.....	89
Plate 71-F. Diving telephone coupling, for helmet gooseneck (female connection)—Disassembled.....	89
Plate 72. Diving telephone, battery type, and sennet-covered combination telephone and life-line cable.....	90
Plate 73. Diving telephone, battery type—Wiring diagram for.....	91
Plate 73-A. Diving amplifier equipment—Amplifier and tender's reproducer front and right side.....	92
Plate 73-B. Diving amplifier equipment—Diver's reproducer and power cables.....	93
Plate 74. Diver's overalls.....	94
Plate 74-A. Tank, test, for diving air system.....	95
Plate 75. Weights.....	98
Plate 76. Shallow water diving apparatus—Miller-Dunn type.....	98

	Page
Plate 77. Shallow water diving apparatus—A. J. Morse Co. type.....	100
Plate 77-A. Shallow water diving apparatus—Ohio Rubber Co. type....	101
Plate 78. Pattern, glove patching—Glove palm section I.....	121
Plate 79. Pattern, glove patching—Patch for glove thumb.....	121
Plate 80. Pattern, strip for securing glove or cuff to sleeve and wood plug for holding sleeve.....	122
Plate 81. Pattern, glove patching—Glove palm section II.....	122
Plate 81A. Gasoline-driven air compressor.....	123
Plate 82. Turnbuckle for securing diving pumps in launch.....	135
Plate 83. Type plan—Installation of diving pump in launch.....	134
Plate 84. Arrangement of diving ladder, decompression stage, and de- scending line on diving launch.....	136
Plate 85. Arrangement of air flasks and connections for divers in motor launches.....	134
Plate 86. Chart—Dew point temperature curve and table of weights in grains of the aqueous vapor contained in a cubic foot of air.....	148
Plate 87. Schaeffer prone pressure method of artificial respiration.....	196
Plate 88. Schaeffer prone pressure method of artificial respiration.....	196
Plate 89. Schaeffer prone pressure method of artificial respiration.....	196
Plate 90. Electrically heated underwear for diving with oxy-helium mix- tures.....	216
Plate 91. Haldane-Henderson gas analysis apparatus.....	218
Plate 92. Helmet oxygen-helium (front view).....	223
Plate 93. Helmet oxygen-helium (side view) left.....	224
Plate 94. Helmet oxygen-helium (side view) right.....	224
Plate 95. Helmet oxygen-helium (rear view).....	225
Plate 96. Helmet oxygen-helium, section of recirculating system, showing CO <sub>2</sub> absorbent, canister and location of baffle.....	229
Plate 97. Helmet oxygen-helium, cross section of aspirator and discharge nozzle venturi.....	229
Plate 98. Oxygen-helium diving manifold front (end) view.....	230
Plate 99. Oxygen-helium diving manifold side view.....	232
Plate 100. Navy standard recompression chamber.....	240
Plate 101. Diving and salvage air lines on submarine rescue vessels.....	241
Plate 102. Diagrammatic arrangement of pontoon.....	243
Plate 103. Oxy-hydrogen under-water cutting torch.....	242
Plate 104. Velocity power pipe bonding press.....	244
Plate 105. Velocity power driver.....	245
Plate 106. Velocity power cable cutter.....	245
Plate 107. Washing nozzle—Falcon type.....	246
Plate 108. Self-propelling circular pipe lance.....	248
Plate 109. Cement gun.....	249
Plate 110. Salvage of U. S. S. <i>Squalus</i> —Arrangement of pontoons—lift of July 13, 1939.....	252
Plate 111. Salvage of U. S. S. <i>Squalus</i> —Arrangement of pontoons—lift of August 12, 1939.....	253
Plate 112. Salvage of U. S. S. <i>Squalus</i> —Arrangement of pontoons—lift of August 17, 1939.....	253
Plate 113. Arrangement of salvage gear used on salvage of U. S. S. <i>Omaha</i> .....	254

## FOREWORD

This Manual supersedes the 1924 edition of the Diving Manual and  
will be effective upon receipt.

CHAPTER I  
DEVELOPMENT OF DIVING AND THE  
TRAINING OF NAVY DIVERS

Records do not clearly show the origin of diving in the United States Navy. While there are evidences of excellent work having been performed at shallow depths in the early days of diving, very little was accomplished at deep depths, and with the crude methods and apparatus available, attempts at the latter usually resulted in the diver's contraction of "bends."

**History.**

The art of diving throughout the world gained noticeable impetus in 1906-7 from the findings of British Admiralty diving experiments, which indicated that a person could withstand with reasonable safety a rapid change of high absolute pressure to proportionately lower absolute pressures, i. e. to such pressures that the ratio of the high absolute pressure is to the reduced absolute pressure as 2.3:1. This meant that a diver working at deep depths could be brought up quickly to a comparatively shallow depth without stopping, and from thereon to the surface with stops at every 10 feet, in lieu of the previous and far less safe method of ascending at a uniform rate from the bottom. The findings of the British Admiralty became known as the stage method of decompression. In principle it is now almost universally employed in deep diving.

A definite program of development of diving was actively begun by the United States Navy in 1912, when extensive tests were conducted in diving tanks ashore, and later, on the U. S. S. *Walke*, in Long Island Sound, to determine the suitability of the stage method of decompression and to improve the standard Navy diving gear to enable deeper diving. The value of the findings was subsequently evidenced in the salvage operations of the U. S. S. *F-4* off Honolulu, in which divers descended to depths of 304 feet—a depth which is believed to be still a record in diving in the ordinary diving suit, using normal air for the diver's air supply.

**Experimental  
Diving Unit.**

The above-mentioned tests were followed by preparation and issue of a United States Navy Diving Manual and the establishment of the Navy diving school at the naval torpedo station at Newport, R. I. This school was subsequently discontinued upon the entry of the United States into the World War. Personnel of this school and some of its graduates formed a nucleus for the overseas salvage division which was established as a unit of United States Naval Forces abroad, and which throughout the war rendered valuable service in salvage operations along the French coast.

With modern submarines being constructed to operate at ever-increasing depths and the possibility of having to salvage such

vessels if sunk, ways and means of enabling divers to attain even greater depths than heretofore were made the subject of special investigation by the Bureau of Construction and Repair in the latter part of 1925, at which time the United States Navy experimental diving unit was created. This unit, composed of naval personnel, was established at the Bureau of Mines Experimental Station, Pittsburgh, Pa., to determine, in collaboration with the Bureau of Mines, the feasibility of using oxygen-helium mixtures as a substitute for ordinary air in diving.

Preliminary experiments on animals having indicated certain advantages in the use of this synthetic air over the air ordinarily used as a diver's supply, the experimental diving unit was subsequently transferred to the Washington Navy Yard as a permanent activity under the Bureau of Construction and Repair to continue the oxygen-helium investigations and other development work incidental to improved diving practices and equipment. The experimental diving unit has functioned accordingly, up to the present time. Such methods prescribed in this edition as depart from past practices, and new diving and salvage equipment shown are, in the majority of cases, the results of findings of the experimental diving unit, the diving school, or the experience gained from past submarine salvage operations.

**Diving School.**

Diving is arduous and hazardous work and the art can be mastered only by training. The ratings in the United States Navy are (1) master diver; (2) diver, first class; (3) salvage diver; (4) diver, second class. Master divers and divers, first class, are qualified at the Deep Sea Diving School. Salvage divers are trained and qualified at the Navy Salvage Training and Diving School, New York City. Divers, second class, are qualified within the fleet, ordinarily on board the submarine rescue vessels. Qualified master divers and divers, first class, are trained and permitted to dive to depths down to 300 feet. Divers, second class, are prohibited from diving to depths in excess of 150 feet.

The Deep Sea Diving School was reestablished in 1926 at the Washington Navy Yard. This location was chosen with the view that its proximity to the experimental diving unit would permit expeditious application of approved experimental findings to standard training curriculum. The school is operated under the cognizance of the Bureau of Naval Personnel, Navy Department, but the diving facilities, gear, and diving boat are furnished and maintained by the Bureau of Ships.

**Diving School faculty.**

The faculty of the diving school usually consists of a commissioned officer in charge with the rank of lieutenant or above, one medical officer, three chief petty officers qualified as master divers, two chief petty officers qualified as divers, first class, one boatswain's mate, first class, and one pharmacist's mate, first class, both of the latter being qualified first-class divers.

**Diving School eligibles.**

Eligibles for diving training are selected from volunteer boatswain's mates, gunner's mates, shipfitters, carpenter's mates, machinist's mates, and torpedomen, preference being given to shipfitters having previous experience in arc welding. Prior to acceptance, each candidate must have passed the rigid physical examination outlined in chapter II. A special course for medical

officers lasting from 10 to 12 weeks is also available. The duration of the standard course is 20 weeks and the classes usually consist of from 9 to 16 students.

The curriculum of the standard course at the diving school includes the following:

**Diving School curriculum.***Standard course*

Work	Location	Time required per man
1. Pressure diving (up to 300 feet).....	Diving tank.....	20 days.
2. Open-water diving tasks: Inspection of ships' bottoms, inspection of ships' propellers and rudders, searching, fitting flanges, blowing up pontoon, underwater cutting with hydrogen torch and underwater washing.	In Potomac River, depth 20 feet.	13 days.
3. Open-water diving tasks: Inspection of submarine fittings, and air-line connections to submarines. Searching in heavy mud and tide.	Potomac River.....	15 days.
4. Underwater burning (oxygen-hydrogen torch).....	Diving tank.....	12 hours.
Underwater burning (electric torch).....	Do.....	20 hours.
Underwater welding (electric torch).....	Do.....	Do.
5. Burning and welding.....	Surface.....	Do.
6. Submarine "lung" training.....	Tank.....	3 hours.
7. Rescue breathing apparatus training.....	Surface.....	2 hours.
8. Elementary instruction and training in the following subjects:		
(a) Caisson disease—cause and treatment.		
(b) Theory of welding. Elementary electric circuits.		
(c) Care and upkeep of suits, helmets, and attachments.		
(d) Diving pumps; care, upkeep, practical computation of diver's air supply and tests of equipment.		
(e) Telephones; care and upkeep of various types, elementary theory of circuits, practical work in overhaul, vacuum tube amplification of primary circuit.		
(f) Velocity power tools, practical work.		
(g) Bureau of Ships Diving Manual.		
(h) Salvage methods and equipment (lectures).		
(i) Oxygen rescue breathing apparatus; care and maintenance.		
(j) Submarine escape apparatus "lung"; care and maintenance.		

Some of the operations and work engaged in by students of the diving school are shown in plates 2 to 5, inclusive.

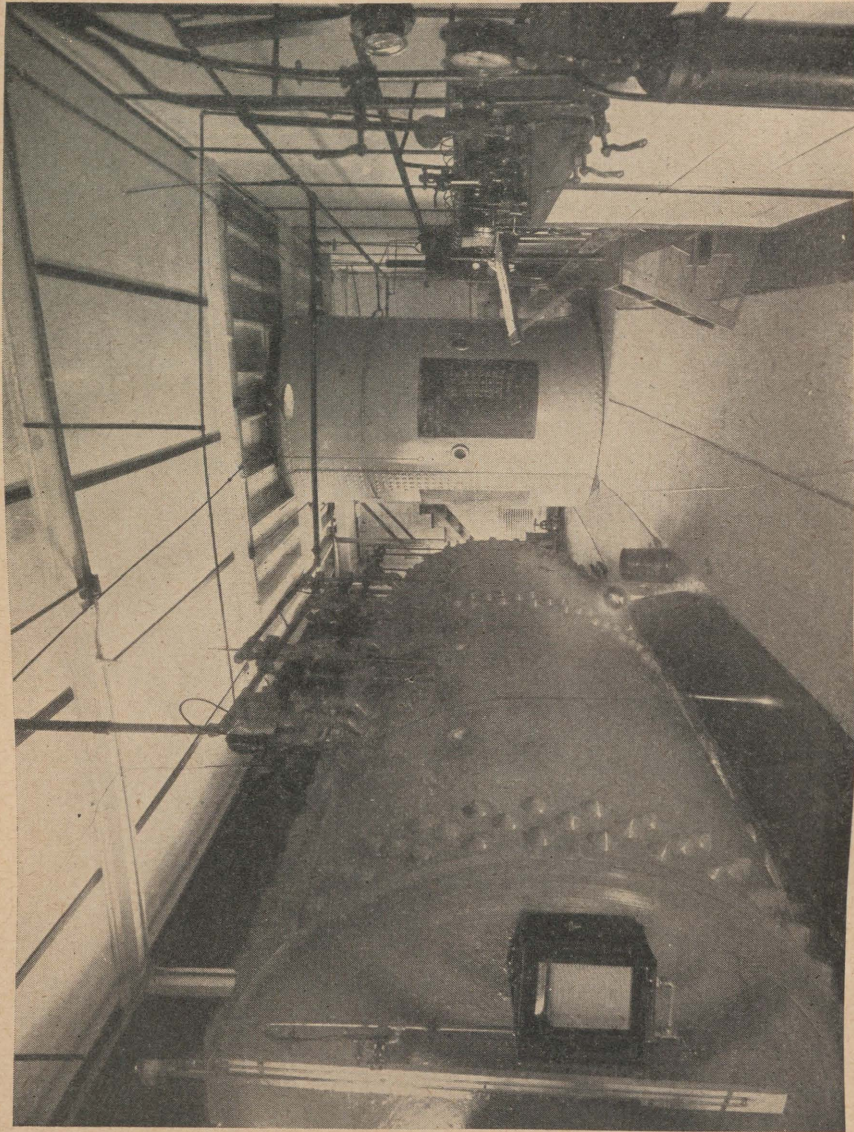

PLATE 1.—Section of first floor of experimental diving recompression chamber (on left) and diving water tank (in background).



PLATE 2—FIGURE 1.—Diver entering diving water tank, diving school.

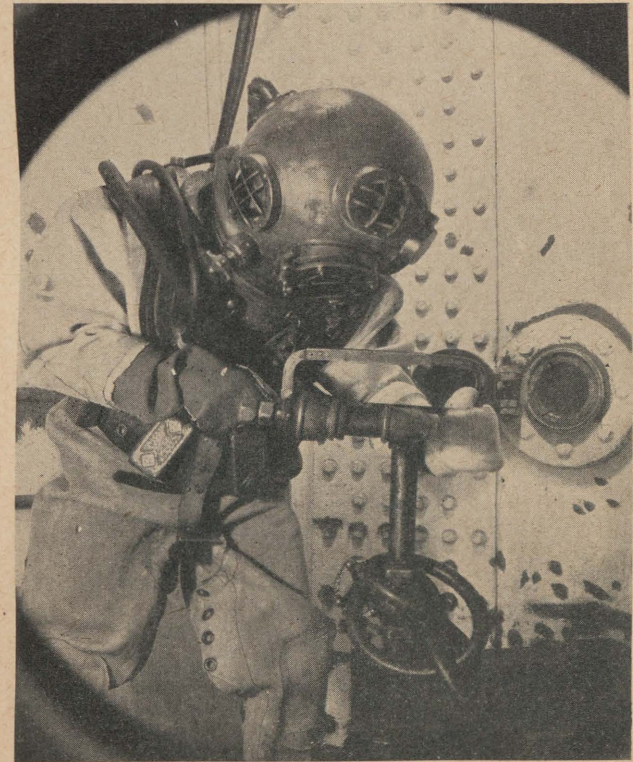

PLATE 2—FIGURE 2.—Diver in water diving tank sawing through a section of steel piping.

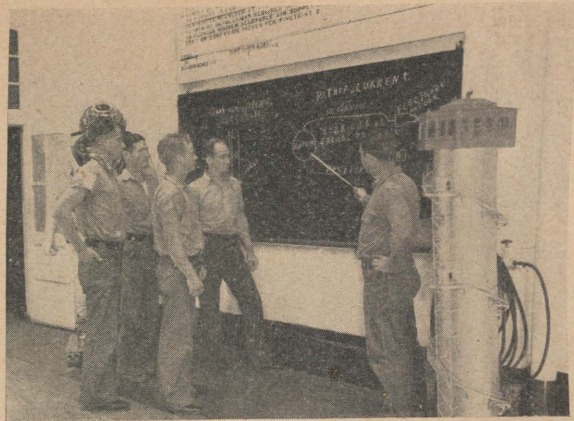

PLATE 3—FIGURE 1.—Lecture on circuits of various above-water and under-water electrical tools and equipment.



PLATE 3—FIGURE 2.—Dressing student diver preparatory to descent in river.

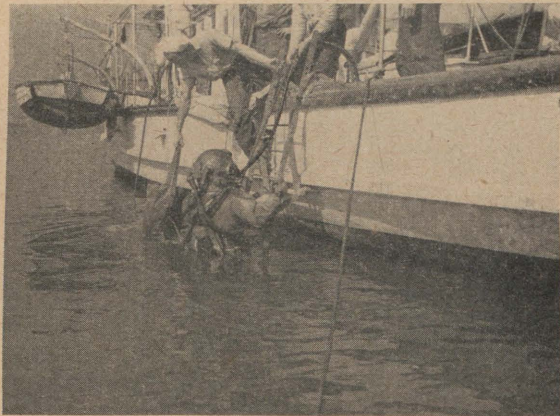

PLATE 3—FIGURE 3.—Student diver descending in river from diving-school boat *Crisley*.

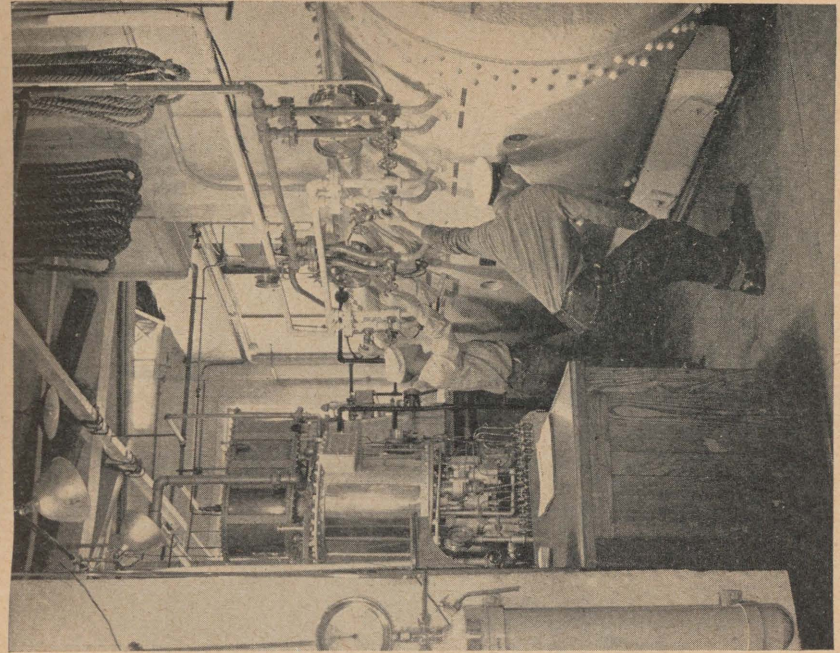

PLATE 4—FIGURE 2.—Diving school recompression chamber—Recompressing and decompressing the diver.

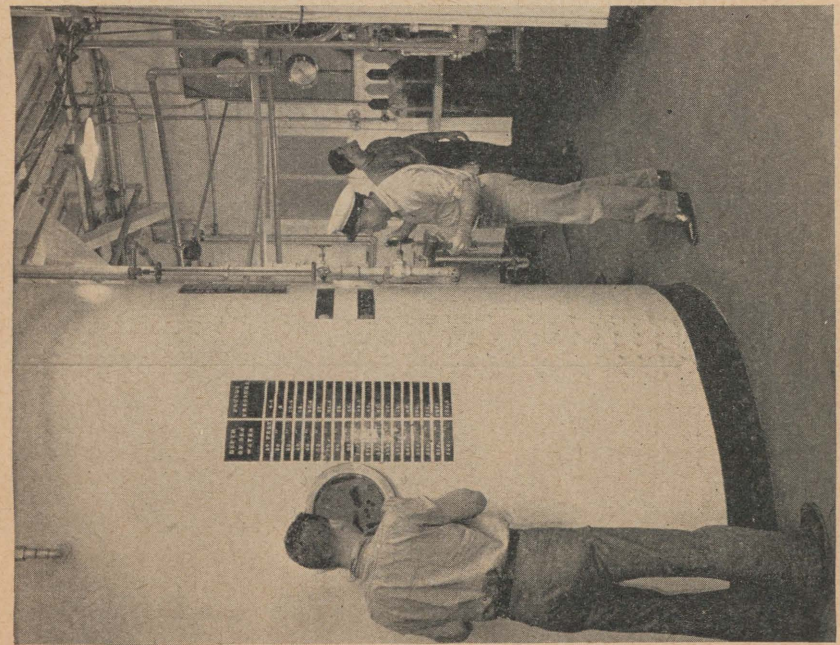

PLATE 4—FIGURE 1.—Diving school—Diving water tank—Observing the diver in tank and regulating the pressure to correspond with water pressures at desired depths.



PLATE 5—FIGURE 1.—Training in above-water burning as a prelude to under-water cutting.



PLATE 5—FIGURE 2.—Diving suit repair work.

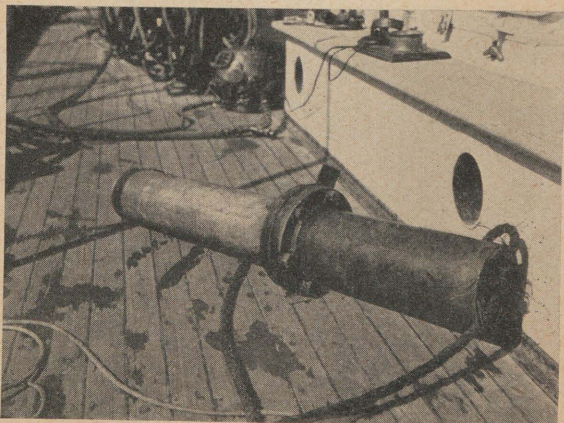

PLATE 5—FIGURE 3.—Sample of flanges fitted under water by student divers.

The facilities of the experimental diving unit and the diving school are practically the same so far as concerns design and principle of operation. They consist principally of a diving water tank, a divers' recompression chamber, standard diving suits and gear, underwater cutting and welding equipment, special tools, air banks, air compressors, and a diving boat. The latter is used jointly by the school and the unit as occasions require. Plate 1 shows a perspective view of the divers' recompression chamber and diving water tank with fittings and attendant air and water piping as installed at the diving school and the experimental diving unit. The water tank is a closed tank with a hinged access hatch at the top to permit entrance of the diver. The tank for the school is about 9 feet in diameter by 12 feet high and is provided with glass ports to permit observation of occupants. The tank is designed to withstand an internal working pressure of 150 pounds and equivalent water depths are simulated by partially filling it with water, closing the hatch, and introducing air at any desired pressure within the working capacity of the tank. The interior of the tank is fitted with telephone, water and electric light connections, and also steam coils to maintain desired water temperatures. The recompression chamber for the school is a two-compartment chamber, designed and constructed for working pressures of 200 pounds per square inch. The diving water tank and the recompression chamber of the experimental diving unit are of the same over-all size and design as the diving school's but are made stronger so as to withstand the greater pressures which obviously have to be employed in experimental work. A detailed description of the recompression chamber is contained in chapter XIX. At this time a new building is being completed for use by the Deep Sea Diving School and the experimental diving unit. This building will enable the diving school to train up to 125 divers first class at one time and will double the research capacity of the experimental diving unit.

Diving School  
and Experimental Diving  
Unit facilities.

CHAPTER II

PHYSICAL QUALIFICATIONS OF DIVERS

General qualification.

All candidates for diving school training shall be examined by a naval medical officer prior to their transfer, in accordance with the instructions set forth herein and in the manual of the Medical Department, United States Navy. Failure to do this may result in subsequent rejection by the diving school, thereby incurring needless expense and loss of time in transporting the men from and to their original station. A diver, to become eligible for training at the diving school, must possess the following qualifications:

1. He must be temperate and possess the physical qualifications necessary to meet the standards required.

2. He must demonstrate his ability to withstand air pressures of 50 pounds (gage) in the recompression chamber, without detriment to the ears or respiratory tracts. These chambers are available on all submarine rescue vessels, at submarine "lung" training tanks, the experimental diving unit, and the deep-sea diving school.

Physical standards.

The physical standards are necessarily high because of the rigorous nature of a diver's duties. The ideal physical type is the young, slender, wiry, phlegmatic individual.

Age.

The most favorable age for training in deep-sea diving is from 20 to 30 years. Candidates for diving training should not be favorably considered if over 30 years of age. Divers, first class, becoming over 40 years of age or becoming unfit to dive in depths in excess of 90 feet are automatically disqualified as diver, first class, but may continue as diver, second class, so long as they remain physically fit for diving to these restricted depths. The upper-age limit in the case of medical officers and hospital corpsmen assigned for diving instructions or as medical attendants to salvage operations or other diving operations involving subjection of themselves to pressure shall be taken as 40 years. The respiratory exchange in young men is faster than in those of middle age, hence the former can rid their bodies of excess nitrogen more rapidly, and therefore are less susceptible to compressed-air illness. Since the efficiency of the blood vascular system decreases with advancing years and as gaseous exchange within the body is vitally concerned with the efficiency of the heart and blood vessels, the younger man is better suited in this respect for diving. Further, with the approach of middle age there is a tendency on the part of the body to accumulate more fat.

Height and weight.

Because of the relatively poor blood supply of fat, fat absorbs and eliminates nitrogen at a slower rate than any other tissue. Since fat when saturated at any given pressure will take up

weight for weight about 70 percent more nitrogen than the blood under the same conditions, it is apparent that the amount of nitrogen held in the body when it is completely saturated at any given pressure will be considerably increased by any increased amount of fat. Therefore, candidates weighing more than 12 percent above the weight prescribed in relation to height in the following table, shall be excluded unless their overweight is largely due to muscle and bone. In order to suit the diving apparatus, men under 5½ feet, and much over 6 feet in height shall not be selected as divers. Specific gravity may be utilized if facilities are available.

Age (years)	Height (inches)	Weight
20	64	140
20	65 and under 68	145
20	68 and under 70	150
20	70 and under 72	157
20	72 and under 74	166
20	74 to 76	171
21	64	143
21	65 and under 68	152
21	68 and under 70	166
21	70 and under 72	170
21	72 and under 74	176
21	74 to 76	181
22 to 25	64	149
22 to 25	65 and under 68	158
22 to 25	68 and under 70	171
22 to 25	70 and under 72	176
22 to 25	72 and under 74	181
22 to 25	74 to 76	188
26 to 29	64	149
26 to 29	65	153
26 to 29	66	158
26 to 29	67	162
26 to 29	68	167
26 to 29	69	171
26 to 29	70	176
26 to 29	71	181
26 to 29	72	187
26 to 29	73	196
26 to 29	74	204
26 to 29	75	213
26 to 29	76	224
30	64	152
30	65	157
30	66	161
30	67	166
30	68	170
30	69	174
30	70	180
30	71	186
30	72	193
30	73	199
30	74	211
30	75	218
30	76	224

A diver should be of the phlegmatic or quiet unexcitable type of personality, for excitement and fright are accompanied by a quickening of the pulse and a rise in blood pressure; and as the rate of saturation and desaturation of the tissues is directly influenced by the circulatory rate, a phlegmatic diver is less likely to develop compressed-air illness than an easily excited diver.

Temperament.

Divers should be men mentally as well as physically fit, as the type of work to be performed often requires quick, accurate judgment and initiative—traits of above-average mentality. Experience has been indicative that there is a relationship between

Mental ability.

low-mental ability and early failure in attempted performance of work under conditions of increased air pressure.

**Habits.**

Divers must be men of moderate habits because alcoholism, loss of sleep, or dissipation contributes to susceptibility to compressed-air illness.

**Vision.**

The field of operations in submerged work is ordinarily inadequately illuminated despite the use of diving lamp, and since it is impracticable to wear glasses in the diving helmet, a good degree of vision is essential. A minimum of 20/20 vision in each eye shall be required for candidates for the designation of diver. The minimum requirement for medical officers and hospital corpsmen shall be 15/20 in each eye. Central color vision shall be normal.

**Respiratory.**

Candidates should be capable of holding the breath after full expiration and inspiration, for a period of at least 55 seconds. This shall be based on the average results of three tests. The lungs perform the all-important function of providing a station for the exchange of gases between the atmosphere and the blood stream, and to perform this task well they must be free from disease. Thus any evidence of pulmonary disease warrants disqualification in a prospective diver. Further, individuals with arrested pulmonary disease are not fit subjects for diving because high atmospheric pressures tend to have an irritant effect on the lungs.

**Cardio-vascular system.**

The set up test for cardiovascular function consists of 20 step ups on a platform 18 inches high performed during a period of 30 seconds. Pulses are recorded sitting at rest, for 5 minutes, 0 to 15 seconds x 4 (A), 5 to 20 seconds after exercise (B), and 120 to 135 seconds after exercise (C).

The cardiovascular score is computed from the expression  $B-70+3(C-A)$ . The elevation of the pulse rate after exercise and the pulse rate decline, govern the score M (C-A), any results 4 or less, are considered zero (0).

The score is rated in the following manner: below 51, good; 51 to 74, fair; and above 74, poor. There should be no tendency toward varicose veins or hemorrhoids. Evidence of arteriosclerosis is sufficient to disqualify.

**Gastro-intestinal system.**

Men subject to gastrointestinal disturbances, with a tendency to excess gas formation in the stomach and intestines, should not be accepted. The marked expansion of such gas on ascending, even from moderate depths, may induce severe symptoms if not readily expelled. For the same reason a diver should not be allowed to dive when constipated.

**Disqualifying diseases.**

In addition to the qualifications discussed in the foregoing, it is desirable that the candidate for diver be entirely free from bodily disease. One of the most important of the disqualifying diseases is middle ear disease. In this malady not only is hearing diminished but often the Eustachian tube is blocked. The Eustachian tube, the membranous tube extending from the middle ear into the throat, allows for equalization of pressure on both sides of the ear drum. Air under increased pressure enters the external ear and depresses the flexible ear drum inwardly. The air also enters the nose and mouth and will enter the inner end of the Eustachian tube if it is patent. By travers-

ing the tube the air reaches the inner surface of the drum through the middle ear, and the pressure on the two sides of the drum are thus equalized and the drum sways outward to its normal position. If the tube is blocked, the increasing pressure on the outside of the drum will continue to depress the elastic drum until it ruptures. However, rupture of the drum from this cause rarely occurs because the pain from the depressed and stretched drum is so intense that the diver cannot continue his descent and must return to the surface. Frequently mucous or local inflammatory conditions such as colds or sore throats will cause temporary blockage of the tube. If mucous be the blocking agent, it can usually be expelled by holding the lips and nostrils closed and exerting pressure with a forced expiration, but if there is an inflammatory condition present, this forced expiratory effort may force infected material through the tube into the middle ear and produce otitis media or infection of the middle ear. Therefore if a cold or other local inflammatory condition be present in the upper respiratory tract, one should not attempt exposure to increased air pressure until these abnormalities have subsided. Ability to equalize pressure in the ears will form part of the physical examination. This ability is ascertained by exposing the candidate to 50 pounds of air pressure in a recompression chamber. Not only are individuals with middle-ear disease not fit subjects for diving, but individuals with any chronic disorder of the upper respiratory tract such as tonsillitis, chronic sore throat, frequent colds, nasal obstructions, or sinusitis are likely to have changes in the tissues of the nose and throat resulting in blockage of the Eustachian tube, and thus eliminate them as candidates for diving. Active skin or venereal disease is cause for immediate rejection. A history of any of the following is disqualifying:

1. Syphilis.
2. Asthma.
3. Persistent high pulse rate.
4. Psychoneurosis.
5. Repeated attacks of sinusitis, etc.
6. Chronic gastrointestinal disturbances.

Qualified divers shall be reexamined periodically in order to detect any disqualifying defects that may have developed since the last examination. A special examination shall be made prior to each diving operation in excess of 36 feet. The results of this examination should be recorded in the diving log and the medical officer should initial the log after this entry, at the same time expressing his opinion as to the individual's fitness for diving on that particular day. A temporary physical defect shall not be considered a cause for disqualification but shall excuse the diver from being ordered to dive, if, in the opinion of the medical officer, his condition warrants it.

At this time the divers are also examined for evidence of colds or other upper respiratory infection. A short history of the activity during the past 24 hours is obtained, in which the following facts are stressed:

1. Amount of sleep. Less than 8 hours' sleep the night previous to diving is thought to predispose to compressed-air illness.

**Reexamination  
prior  
to dive.**

2. Alcohol. Divers are not allowed to dive if any alcohol has been consumed in the last 24 hours.

3. Constipation seems to have a debilitating effect on the diver and lack of bowel movement in 24 hours may predispose to an attack of caisson disease.

4. In addition to the nose and throat examination the diver is asked if he has any symptoms of either colds or sore throat.

All the foregoing information is recorded on a diving form the last line of which should contain an expression of opinion by the medical officer as to the diver's physical fitness to dive on that particular day.

While it is not intended to restrict procedure in the reexamination of qualified divers, it appears that the foregoing cited method employed at the experimental diving unit and the diving school could well be followed in the fleet.

**General considerations.**

Although a certain latitude may be allowed for a diver of long experience and a high degree of efficiency in diving, he must be free from any diseases of the cardiovascular, respiratory, gastrointestinal, or genitourinary systems, and of the ear; and his ability to equalize pressure must be maintained. A slight degree of overweight may be disregarded if the diver is otherwise vigorous and active.

When long salvage operations are in progress, it has been found that better results are obtained if the divers are relieved periodically from duty and removed from existing environment. Accordingly, where daily diving over long periods of time is involved and there are sufficient divers, liberty in individual cases should be given as often as practicable. However, the divers should be cautioned as to the detrimental effects of the loss of sleep, alcohol, etc., to their well-being in diving. If admonishment does not suffice, it is best to prohibit liberty in individual cases the day preceding the dive.

If the number of divers permits, division into three groups is advisable, two groups diving for a period of a week while one group is given leave. Each group, however, should be sufficiently large to enable continuous diving in medium depths, in relays of three divers, who under ordinary salvage procedure, are usually submerged simultaneously.

Divers should not be made to dive for at least 1 hour after a light meal and 2 hours after a heavy meal.

## CHAPTER III

### NAVY STANDARD DIVING OUTFITS

The standard diving outfits used by the Navy consist of two classes. They are the deep-diving outfits and the shallow-water-diving outfits.

Deep-diving outfits are of three types commonly known as outfits No. 1, No. 2, and a special outfit which will henceforth be known as outfit No. 3. Shallow-water-diving outfits are of one general type.

Diving outfit No. 1 consists of equipment necessary for two divers, including a two-cylinder, double-acting, manually operated, air pump and an adequate number of spare parts.

Diving outfit No. 2 is similar to the No. 1 outfit, except that it is provided with only one helmet.

Diving outfit No. 3 consists of special equipment used only by submarine rescue vessels.

The new standard shallow water outfit consists of a Victor Berge type face mask, a shallow water diver's air pump, volume tank, hose, underwear, sneakers, nonreturn valve, instruction manual and stowage box.

The old shallow-water-diving outfit consists of a light-weight copper helmet with suitable weights attached, a hand-operated air pump, and a 50-foot length of air hose.

Diving outfits Nos. 1 and 2 are suitable for use in both deep and shallow water. Shallow-water-diving outfits are for use in temperate and tropical waters of depths not exceeding 36 feet when using the hand pump. Greater depths are permitted in certain cases as set forth in chapter XV.

Diving outfits No. 1 are furnished to tenders, fleet tugs, repair ships, salvage vessels, and floating dry docks, or to other vessels whose mission requires them to be capable of undertaking extensive diving operations.

No. 2 diving outfits are supplied to auxiliaries and combatant ships, which would only need a diving outfit to perform minor repair or inspections.

No. 3 diving outfits are supplied to submarine rescue vessels.

The shallow-water-diving outfit is suitable for use of only one diver at a time.

With a few exceptions diving outfits Nos. 1, 2, and 3 are initially issued in their entirety. The exceptions are (1) in cases where the diving work engaged in is of too minor a nature or too infrequent to warrant the issue of complete outfits, and (2) where the frequency of the work and its nature are such as to require more equipment than is contained in one outfit but less than that contained in two complete outfits. The Bureau of Ships allowance lists designate the type of diving outfits and the

quantities of the respective items comprising such outfits to be carried by vessels of various types.

Item	Article	Unit	No.		
			1 outfit	2 outfit	3 outfit
1	Bags, tool	Number	2		6
2	Belts, weighted	do	2	1	8
3	Box, spare parts	do	1	1	
4	Cement, rubber	Quarts	2	12	12
5	Chest, helmet	Number	1	1	
6	Chest, outfit	do	3	2	
7	Clamps, air hose, spare	do	12		12
8	Cloth, rubber, patching	Yards	2	1	4
9	Coupling, air hose, female	Number	2	1	6
10	Coupling, air hose, male	do	2	1	6
11	Coupling, air hose, double, female	do	2	1	6
12	Coupling, air hose, double, male	do	2	1	6
13	Cuffs, rubber	Pairs	8	2	
14	Cushions, helmet	Number	2	1	6
15	Drawers, under, woolen, size 36	Pairs	6	3	4
16	Drawers, under, woolen, size 38	do	6	3	12
17	Drawers, under, woolen, size 40	do	6	3	8
18	Dresses, diving No. 1	Number	1	1	4
19	Dresses, diving No. 2	do	3	1	12
20	Dresses, diving No. 3	do	2	1	4
21	Faceplates, complete	do	1	1	4
22	Faceplates, welding	do	1		
23	Flag, baker	do	1		
24	Gaskets, faceplate, spare	do	2	1	6
25	Gaskets, helmet, leather, spare	do	4	2	10
26	Gaskets, nonreturn valve seat, rubber	do	4	6	
27	Glasses, helmet, face	do	2	1	6
28	Glasses, helmet, side	do	1	1	6
29	Glasses, helmet, top	do	1	1	3
30	Gloves, diver's—tender, combination	Pairs	8	2	24
31	Gloves, woolen	do	4	2	18
32	Glycerine	Pints	1		
33	Hallard, signal	Feet	20		
34	Helmets, complete	Number	2	1	7
35	Hose, air, high pressure, 3-ft. lengths	do	3	1	12
36	Hose, air, high pressure, 50-ft. lengths	do	12	4	68
37	Knives and cases	do	2	1	10
38	Ladder, iron, galvanized	do	1	1	1
39	Lead, sounding—7 lb	do	1		
40	Lenses, welding No. 4	do	12		
41	Lenses, welding No. 6	do	3		
42	Lenses, welding No. 8	do	3		
43	Light (weatherproof sockets guard for 100-watt bulb and 200-ft. cable)	do		1	
44	Light, with 200-ft. cable	do	1		
45	Manifolds	do	1	1	3
46	Line, sounding, 200 ft	do	1		
47	Litharge	Pounds	2		
48	Lines, descending, 200-ft. length	Number	2		
49	Lines, distance, 60-ft. length	do	3		
50	Manual, diving	do	1		
51	Nuts, wing, breastplate, large	do	4	2	15
52	Nuts, wing, breastplate, small	do	8	4	30
53	Oil, neat's-foot	Quarts	2	1	
54	Packing, air control valve, flax—1/8"	Pounds	1 1/2		
55	Pump (hand- or gas-driven)	Number	1	1	
56	Reducer type "S"	do	4	2	18
57	Reducer type "T"	do	2	1	6
58	Safety latch, helmet, spare	do	1		
59	Screws, machine, brass, 8 x 32 x 3/8"	Boxes	1		
60	Separator, oil	Number	2	1	8
61	Separator, oil filter, spare	do	6		4
62	Separator, oil gaskets, spare	do	6		4
63	Separator, oil washers, spare	do	12		12
64	Shoes, weighted	Pairs	2	1	6
65	Shoes, light weight	do	1		
66	Socks, woolen	do	12	3	48
67	Springs, regulating escape valve, primary and secondary spares	Number	6	2	12
68	Stages, decompression	do	1		2
69	Straps, leather with buckle (for diving gloves)	Pairs	2	2	
70	Stop watch	Number	1		
71	Studs, breastplate, short	do	8	4	18

<sup>1</sup> Pints.

Item	Article	Unit	No.		
			1 outfit	2 outfit	3 outfit
72	Studs, breastplate, long	Number	4	2	6
73	Taps for all female fittings	do	1		
74	Telephone outfit, complete, as follows:				
	(a) Amplifiers	do	1	1	3
	(b) Transceivers (3 supplied originally with amplifiers)	do	3	3	12
	(c) Cable combination telephone and life line, complete with connection in 200-ft. lengths	do	3	1	2
	(d) Spare parts for amplifier and transceiver	do	1	1	
	(e) Boxes, jack, for helmet gooseneck including spares	do	3	2	10
	(f) Connections, double, female, spares	do	2	1	3
	(g) Washers, leather for cable	do	20	12	50
	(h) Packing for couplings	Pounds	2	1	10
75	Threading, dies, male fittings	Number	1		
76	Trousers, overalls	do	3	2	9
77	Tubing, rubber, elastic	Yards	2	1	20
78	Undershirts, woolen, size 38	Number	6	3	6
79	Undershirts, woolen, size 42	do	6	3	12
80	Undershirts, woolen, size 44	do	6	3	6
81	Valves, air control	do	2	1	12
82	Valves, regulating escape	do	2	1	6
83	Valves, safety air nonreturn	do	4	1	6
84	Washers, copper, clamp joints	do	12	6	
85	Washers, leather, air hose, spare	do	36	12	60
86	Weights, cast iron, 50 lb	do	1		12
87	Weights, cast iron, 100 lb	do	2	1	12
88	Wrench, single open end air hose	do	2	2	6
89	Wrench, spanner, safety valve	do	1	1	
90	Wrenches, T helmet	do	4	2	6
91	Wrench life line and telephone coupling	do	2	1	6
92	Buoys, cork, pyramidal or oval shape	do			12
93	Buoys, steel, spherical, 18"	do			4
94	Buoys, steel, spherical, 22"	do			4
95	Gloves, leather, wire handling	Pairs			18
96	Hooks, cutting for severing antennae wires, rails, etc., C & R plan No. 144255				4
97	Punches, cutting for collars of diving dress				1
98	Drags, electric				1
99	Stools, divers' dressing, C & R plan No. 144581				3

## CHAPTER IV

### DESCRIPTION OF NAVY STANDARD DIVING GEAR

Bag, tool, diver's.

1. The diver's tool bag (pl. 10) is made of No. 6 canvas. The bottom is perforated with five No. 4 spur grommets. These grommets allow the bag to flood or drain rapidly. This bag is strong enough to carry any tool the diver may need or is capable of using, except a crowbar. It will carry weights up to approximately 200 pounds. Very small articles should be secured to the bag by individual lengths of marline and tied either to the handle or through the grommets. When the tool bag is normally loaded, it is carried over the right arm; when heavily loaded, it should be sent down the descending line.

Belt, weighted.

The weighted belt (pl. 11) is used to furnish negative buoyancy when the diver's dress is moderately inflated. The belt is made of  $\frac{1}{4}$ -inch waterproofed, double-backed, chrome tanned leather. The lead weights are secured to the belt with  $\frac{5}{16}$ -by 2-inch countersunk screws, the heads of which pass through special No. 4 spur grommets inserted in the leather; thus they may be removed or replaced easily, as the occasion may require. Metal strap hangers are cast in four of the weights, the two center ones being set at angles to give proper leads to shoulder which pass over the breastplate of the helmet and cross in the back so as to counteract any tendency the belt may have to shift its position.

The jock strap is provided for the dual purpose of holding the belt down in its proper location and to prevent the helmet from rising over the diver's head which it would do if elongation of the dress through this overinflation were not prevented.

The present diving belt is the result of progressive development over a considerable period of time. Substitutes such as plain lead diving weights of various shapes, or metal hinged belts and lead weighted belts made of strong webbing, have been tested and found unsatisfactory. Experience has indicated that the present Navy standard diving belt is more comfortable, more capable of adjustment, and contributes to a better balance of the diver than belts of any other design or construction investigated to date.

Box, pump, piston leathers.

The box for spare pump piston leathers (pl. 12), figure 3, is made of 27-gage tin. All joints, including those in the top, are soldered to prevent the neat's-foot oil in which the leathers are soaked from leaking out. This cylindrical box is  $4\frac{1}{2}$  inches high and 4 inches in diameter. The box with its contents should be stored in the wooden sill built into the back and at the top of the pump case. Each box should contain two piston cup leathers and three leather piston washers.

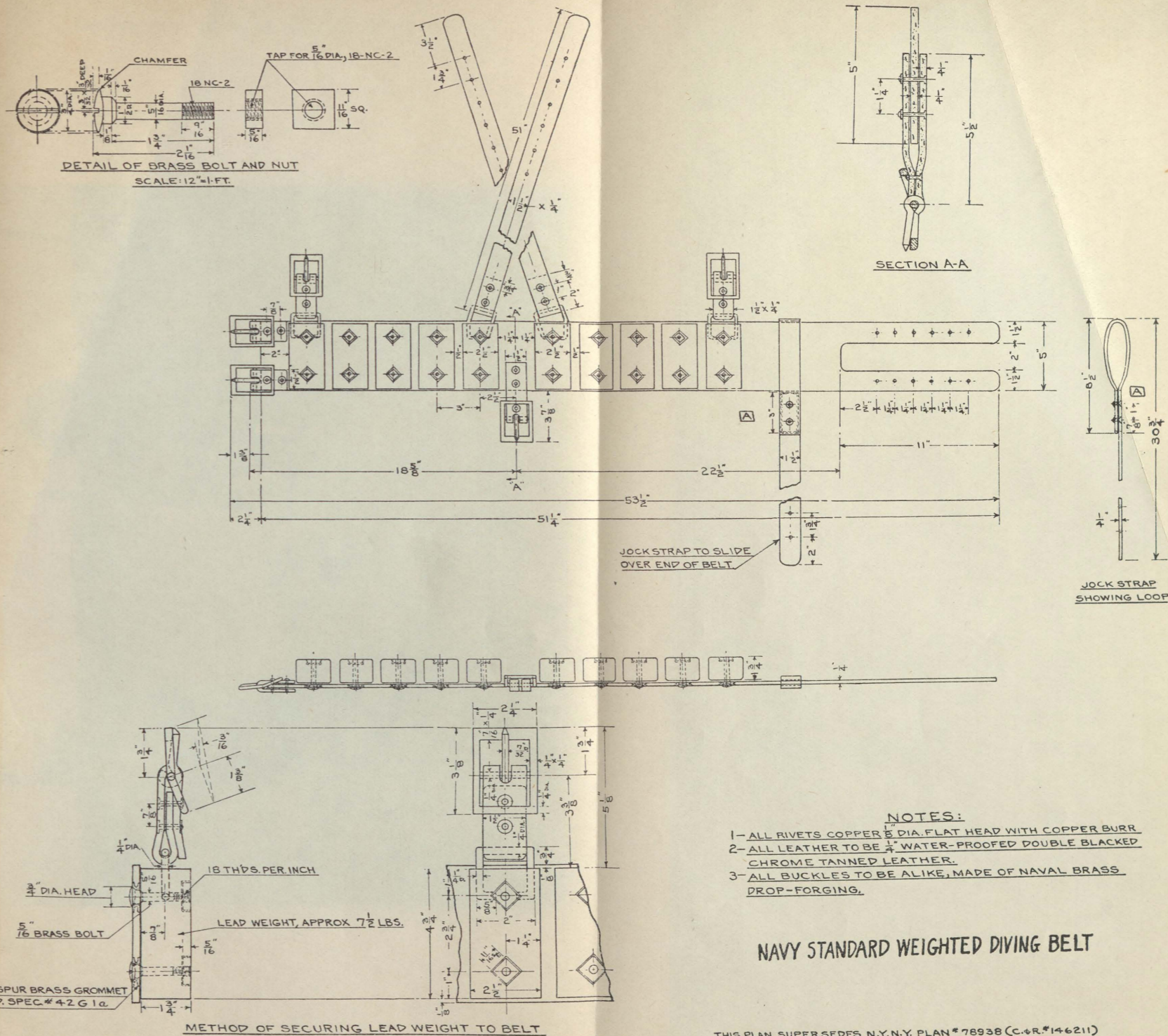

PLATE 11.—Diver's weighted belt.

THIS PLAN SUPERSEDES N.Y.N.Y. PLAN # 78938 (C.R.# 146211)

646428—45 (Face p. 18)

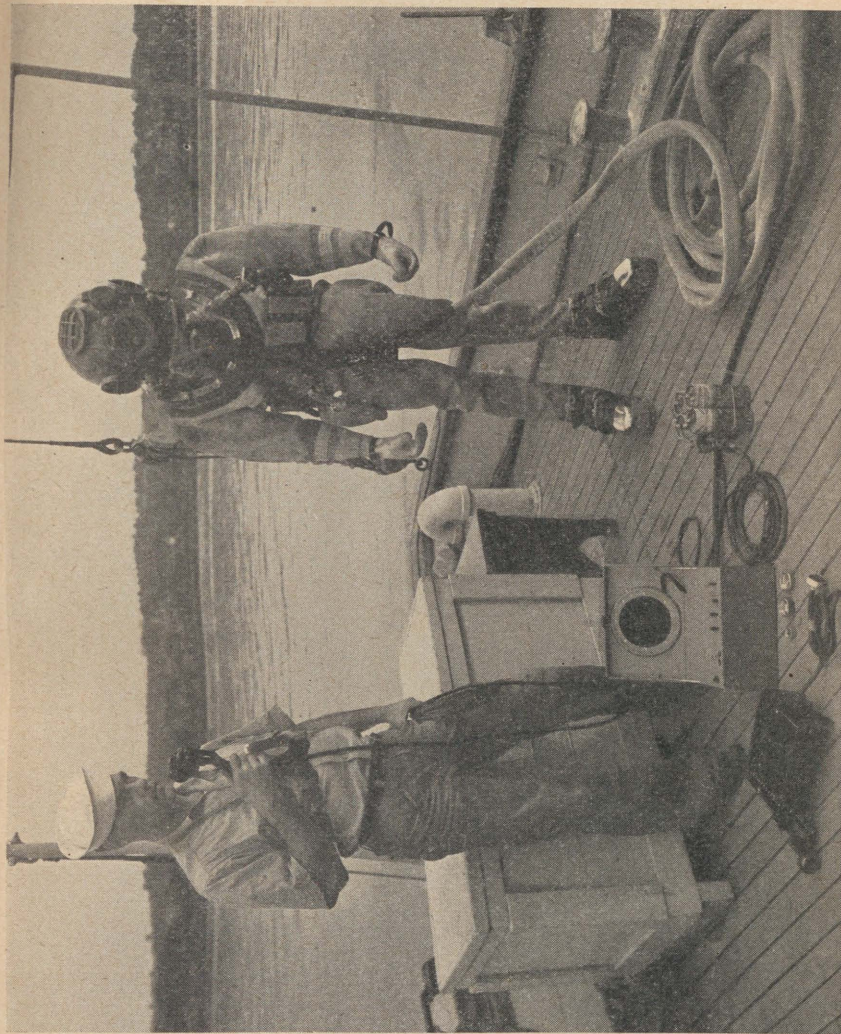

PLATE 6.—Diver completely dressed: Attendant with telephone.



PLATE 7.—Diver partly dressed—Front view.



PLATE 8.—Diver partly dressed—Back view.

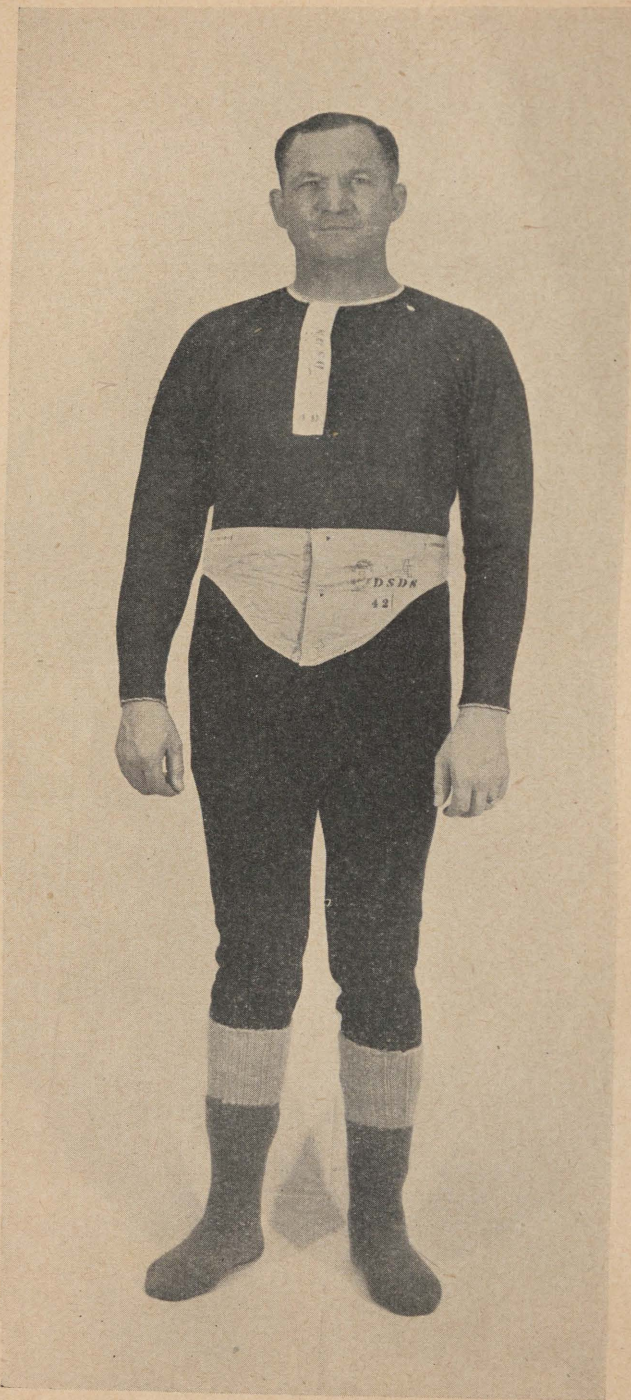

PLATE 9.—Diver partly dressed—Showing underwear.

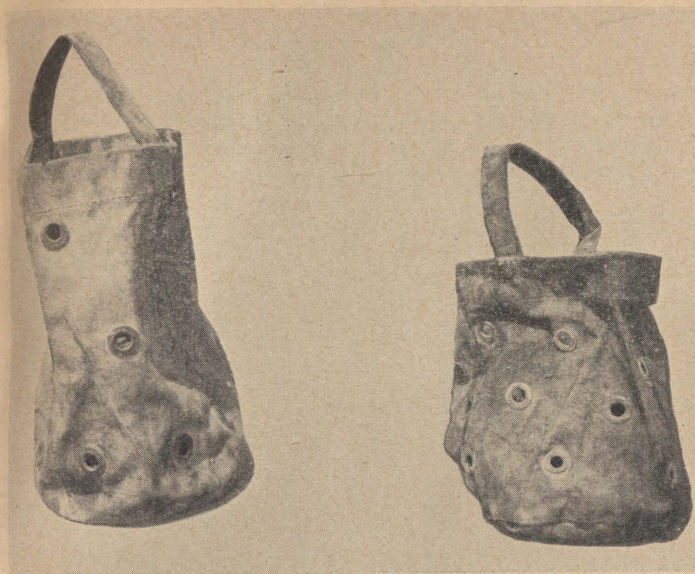

PLATE 10.—Tool bag.

The spare parts box, (pl. 12) figure 2, is made of 27-gage tin soldered along the bottom and sides to prevent leakage of oil that may drain from the spare parts. The box is circular and is 3 inches high by  $3\frac{3}{8}$  inches in diameter.

Box, spare parts.



PLATE 12.—Boxes, tin, for piston leathers and for spare parts.

This box contains the following spare parts of diving equipment: 4 pump valves; 12 hose washers; 4 suction valve gaskets; 2 outlet valve gaskets; 4 suction valve cap gaskets; 4 valve stem washers; 2 bedplate nuts; 2 outlet valve cap gaskets.

The cork buoys furnished with diving outfits are of the best quality sheet cork and are either pyramidal in shape, as shown on plate 13, or oval. They are made of one or more pieces of cork secured by a  $\frac{1}{2}$ -inch diameter galvanized-iron through bolt fitted at each end with a galvanized washer. Each end of the

Buoys.

through bolt terminates in an eye of 1-inch inside diameter. One eye is swiveled. The buoy has an initial buoyancy in salt water of approximately 20 pounds. The oval buoy is approximately 7½ inches in diameter at its midsection. Its length between washers is approximately 16 inches. The pyramidal buoy is approximately 16 inches long, 8 inches thick at its midsection, and 5½ inches square at its ends.

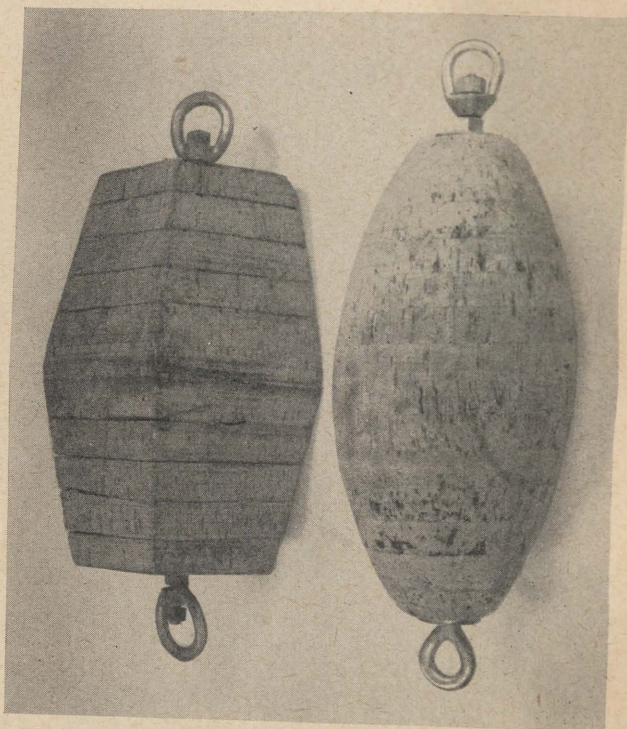

PLATE 13.—Buoys, cork.

Cable combination telephone and life line.

The telephone cable serves the dual purpose of a telephonic communication circuit and a life line. It is known as a combination telephone and life-line cable.

At the present time there are two different types of diving telephones in service and consequently two different types of cable. The majority of the cable now in use except on submarine rescue vessels is the sennit-covered cable forming a part of old battery-type telephones which were standard in the Navy up until the U. S. S. *S-4* salvage operations. This cable consists of three electrical conductors marked red, white, and blue, respectively, separated throughout the length of cable by a brown thread heart. The conductors, and the heart are encased in a woven cover, the whole assembly being enclosed by sennit-laid outer cover. These cables have no central strength member. Their ultimate strength is therefore that which is afforded by the conductors. Experience has indicated that their maximum strength of only about 350 pounds is not sufficient to withstand

the stresses imposed on them under some conditions attendant on salvage operations. The copper conductors have a tendency to stretch permanently under heavy loads. This elongation is not uniform in the respective conductors, and the result is that one conductor usually is subjected to the full load with subsequent failure. When present stocks of this type cable are exhausted, its issue will be discontinued.

During the salvage operations of the U. S. S. *S-4* there was developed a rubber-covered cable of approximately 7/8-inch diameter with a breaking strength of about 5,000 pounds. The cable consisted of a phosphor bronze wire rubber-covered central member around which six insulated copper conductors were spirally laid and covered with a tough outer rubber molded cover. The conductors were connected in parallel and so arranged that fracture of any one of them up to a total of four would not break the circuit. These cables were made in 600- and 200-foot lengths. They were used throughout the salvage operations of the U. S. S. *S-4* and found superior to the sennit-covered cables described above. However, subsequent and continued use of these cables indicated them to be unnecessarily heavy and stiff. Some of these cables are still in use but replenishment of stocks is being made with cables of lighter weight. They are not suitable for use with the old battery-type telephones nor with the present standard telephones.

Subsequent to the U. S. S. *S-4* salvage operations there was developed a diving telephone cable of an overall diameter of 5/8 inch having a breaking strength of approximately 3,000 pounds. The cable is somewhat similar in construction to the 7/8-inch cable described above except that it has only four conductors and the core or hoisting member is of corrosion-resisting steel in lieu of phosphor bronze. This cable is also furnished in 600- and 200-foot lengths. It has been in service for several years and the consensus of opinion is that it is superior to all previous types furnished. This cable has been adopted as Navy standard diving cable. While developed primarily for use with the amplifier type of telephones described in this chapter, the connections are equipped with adapters which permit satisfactory use of the cable with old battery-type telephones. Plate 72 shows the sennit-covered cables and plate 14 the light-weight rubber-covered cables described above.

Helmet and diving-gear outfit chests (pls. 15 to 18, inclusive) are made of 7/8-inch thick white ash. The sides are dovetailed and the entire chest is reinforced around the bottom and top of the sides with a 3¼ by ½-inch baseboard and a 2 by ½-inch beading. Inside measurements of the helmet chest are approximately 40 by 20 inches with a depth of 21½ inches and it is divided equally into two compartments. The inside measurements of the outfit chest are 44¼ by 17¼ inches with a depth of 17½ inches.

The helmet cushion (pl. 19), figure 3 as the name implies, is a cushion on which the helmet rests, thereby protecting the diver's shoulders when he is out of the water and is supporting the total weight of the helmet and attached parts, which is well over 100 pounds. The cushion is made of tan-colored 8-ounce drill, padded

Chests, helmet and outfit.

Cushion, helmet, Diving dress.

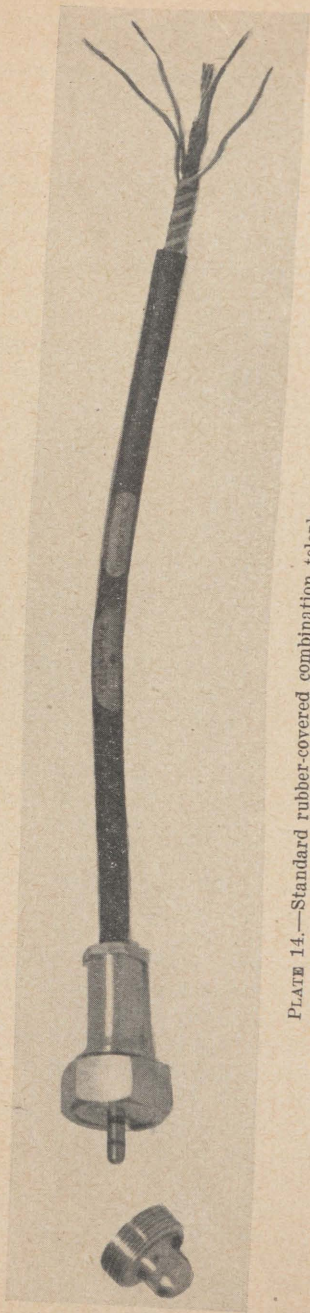

PLATE 14.—Standard rubber-covered combination telephone and life-line cable.



PLATE 15.—Diving outfit chest—Inside view.



PLATE 16.—Diving outfit chest—Front view.

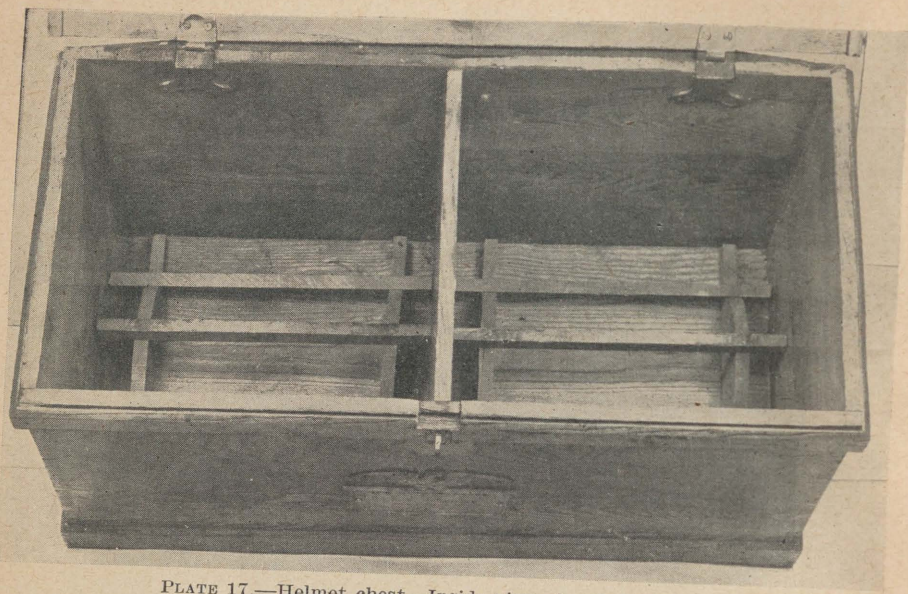

PLATE 17.—Helmet chest—Inside view showing cradles.

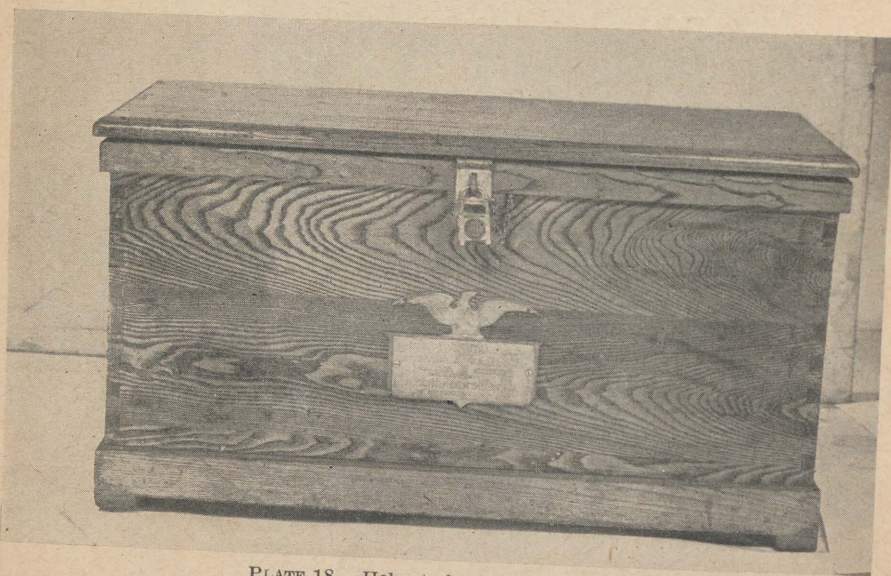

PLATE 18.—Helmet chest—Front view.

with a layer of best quality hair felt 1 inch in thickness. It is worn around the neck inside the diving dress.

The Navy diving dress (pls. 6, 7, 8, 20, and 22) is made of the best white American diving dress fabric and is so constructed that it encloses the entire body except the head and hands. The diving dress fabric consists of vulcanized sheet rubber between layers of cotton twill—this construction rendering the fabric water and air tight. The dress is reinforced at the points of wear by chafing patches of the same material cemented in place. The neck of the dress is fitted with a rubber gasket through which holes have been molded to fit the studs of the breastplate. The gasket is fitted with a duck reinforcing webbing that starts, as near as practicable, at the bead and extends laterally half the width of the collar. The inner edge of the collar has a molded bead of rubber on the outside. This strengthening bead fits against the breastplate straps. A portion of fabric called the bib is also secured inside the neck of the dress. The helmet breastplate fits between the rubber gasket and the bib. The bib fits loosely and comes up well inside the neckpiece of the breastplate and serves to prevent any water that may enter the helmet through the valves from contacting the diver's body.

Diving dress.

Elastic rubber cuffs are cemented to the sleeves of the dress as required to make watertight the joint at the wrists. The cuffs (pl. 21) which are of molded rubber, are 8 inches long,  $3\frac{1}{4}$  inches wide at the bottom, and 6 inches wide at the top. The cuff tapers toward the bottom 1 inch in 5 inches to a point 5 inches from the top and from this point tapers  $1\frac{3}{4}$  inches in  $1\frac{1}{2}$  inches. At the diver's wrist where the wristband terminates, the cuffs are reinforced with a flattened ridge of rubber approximately  $\frac{3}{16}$  inch thick and  $\frac{1}{4}$  inch wide. In the case of divers having very large wrists, the cuffs of the diving dress will sometimes fit too tightly and interfere with circulation of blood to the hands. In such cases the remedy is to cut a little off the ends of the rubber cuffs until the joints are made comfortable.

Cuffs.

The legs in the Navy standard diving dresses are shorter and the body of the Navy diving dress longer than those of commercial diving dresses. These characteristics of the Navy dress are sometimes criticized as restricting the diver when mounting the diving ladder, searching on the bottom, etc. The short legs of the Navy dress not only prevents the jock strap from bearing on the diver's crotch but also affords sufficient slack in the back of the suit to permit the diver to stoop as necessary—characteristics which are considered essential in the deep diving involved in Navy submarine rescue and salvage operations.

Flaps for lacing the dress to the diver's legs are provided on the fore legs and upper legs of the dress to prevent an accumulation of air in the lower portion of the dress. This provision tends to lessen the danger of accidental "blow-up" and risks incidental to capsizing. A diver should never be put into the water unless the flaps are snugly laced.

Navy diving dresses are made to fit the Mark V—Mod. I helmet and are furnished in three sizes; viz., No. 1, small; No. 2, medium; and No. 3, large. The No. 1 dress is designed to fit divers

5 feet 7 inches to 5 feet 9 inches tall. The No. 2 dress is designed to fit divers 5 feet 9 inches to 5 feet 11 inches tall. The No. 3 dress is for divers 5 feet 11 inches to 6 feet 2 inches tall. Diving dresses have the following measurements:

	No. 1	No. 2	No. 3
Front center seam—from center of the center hole in the collar to the crotch seam.....	25¾	27¾	33¾
Back center seam—from center of back hole to center seam of crotch.....	28¾	32¾	36¾
Leg seam—from heel to center crotch.....	32	33	34
Arm seam—from seam under armpit to edge of cuff (upper edge).....	15½	16½	17½
Sleeve shoulder measurement (halved).....	11	11	11
Measurement around body at point halfway between chest measurement and 12 inches above crotch.....	48	48	48
Chest measurement at base of armhole.....	54	54	54

In working around wreckage or in extended diving operations overall trousers shown on (pl. 74) and described at the end of this chapter are worn over the diver dress to protect the dress from chafe and wear.

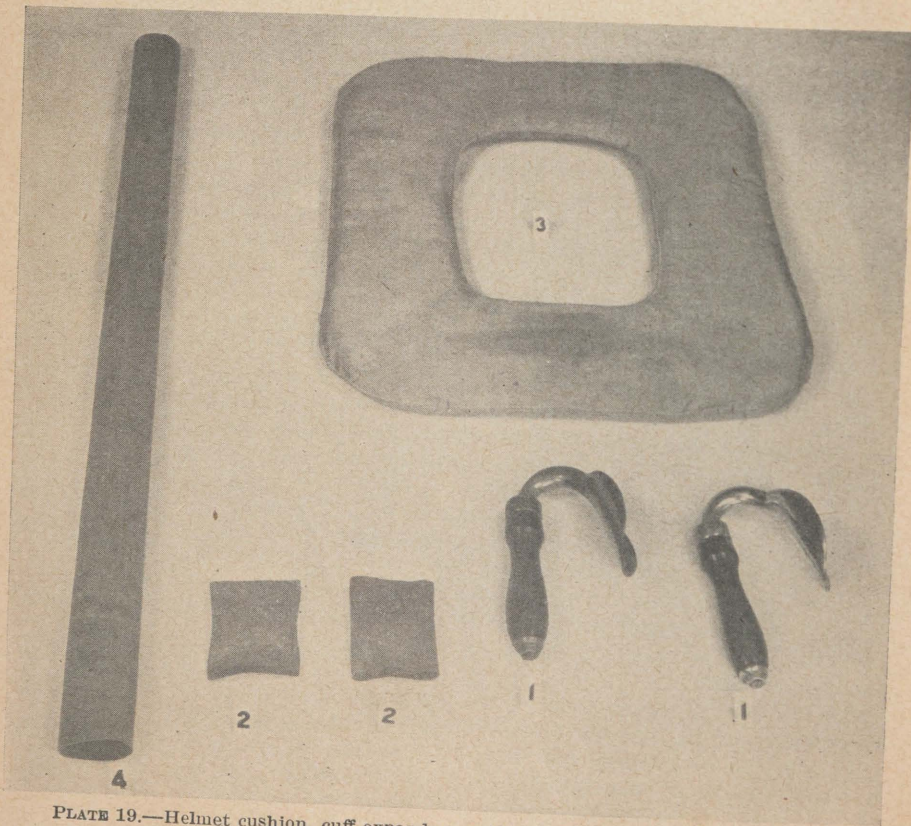

PLATE 19.—Helmet cushion, cuff expanders, rubber tubing, and rubber wrist bands.



PLATE 20.—Standard diving dress, with cuffs attached—Front view.

Gages, pressure, air pump.

Two pressure gages of the type shown on plate 60 (Fig. 7) are installed on all diving air pumps of deep-diving outfits. When the pumps are operated, these gages record both the pressure of air being delivered and the corresponding depth of water when the diver's air-control valve is open.

Gloves, combination diver's and tender's.

Gloves of the type shown on plate 23 were designed for the use of divers and divers' tenders. They are made of rubber, molded to shape, and reinforced with heavy cloth in the palm extending to the wrist joint. The glove has two fingers and a thumb which are also reinforced with the same cloth material extending well over the tops. The gloves are molded so that the fingers are permanently curved as in a half-closed hand, thus eliminating strain on the fingers, which would otherwise occur when the diver is performing work requiring use of his

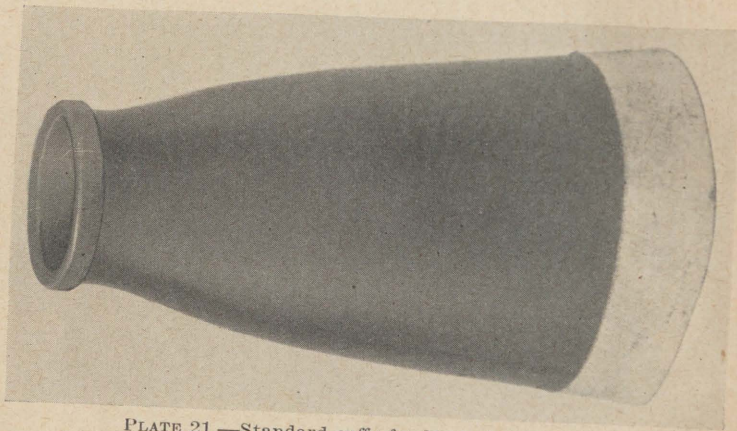

PLATE 21.—Standard cuffs for Navy diving dress.

hands. The palm of the glove is shaped so that it still conforms to the shape of the diver's palm when the hand is closed. The glove is made in one size only but is large enough to be worn over a woolen glove. It fits the diver's wrist snugly. At a location of about 2 inches on the forearm the glove-wrist is not more than  $3\frac{1}{2}$  inches nor less than  $3\frac{1}{4}$  inches wide. It then tapers to  $7\frac{1}{2}$  inches in a length of 7 inches and terminates in a band which is reinforced outside with drill. The gloves should be attached to the dress and used when diving in cold water and when operating the electric underwater cutting or welding torch. The arms of the dress with the gloves attached are not adjustable and because of this, some divers have difficulty keeping the hands all the way in the gloves. In order to overcome this condition, wrist straps made of chrome tanned leather are furnished.

Gloves, woolen.

Woolen gloves are provided for use under the combination diver's and tender's rubber glove described in the foregoing, in cold-water work. They are dark blue in color and are made in accordance with the latest issue of Navy Department specifications for ordinary woolen gloves. Dark colors are preferable when the woolen gloves are worn without the rubber gloves.

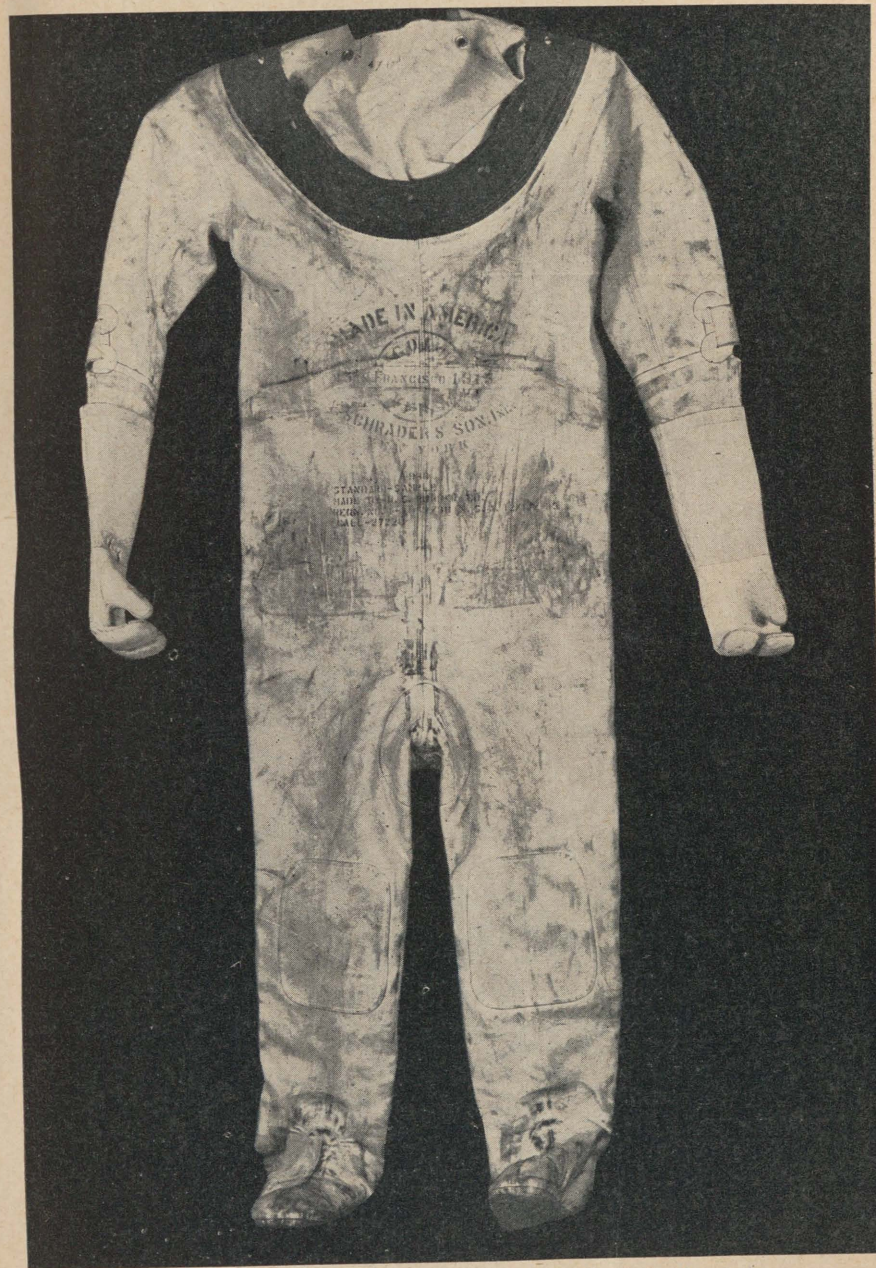

PLATE 22.—Standard diving dress, with gloves attached—Front view.



PLATE 23.—Standard divers' and tenders' glove.

#### Helmet.

The diving helmet (pl. 24) adopted as standard for the Navy for deep diving is designated as "Diving helmet—Mark V, Mod. I." It consists of a tinned copper spherical helmet, which incloses the diver's head, and a breastplate. The fittings are of gun metal. The connection between the helmet and breastplate is made by an interrupted screw joint. A leather gasket fitted in a recessed gasket seat on the breastplate insures a watertight joint when the helmet is attached. When screwed in place on the breastplate, a safety catch, located on the back of the helmet, is turned down into a recess cut into the neck flange of the breastplate to prevent the helmet being accidentally detached. To prevent the safety catch from accidentally dropping out of the recess by gravity or otherwise, there is provided a clamp which in its locked position closes the gap in the recess. Design and dimensions of the clamp are shown on plate 25. This clamp is shaped to conform with the curvature of the breastplate neck flange. It is hinged at one end to the neck flange of the breastplate and locked at the other end to the flange with a  $\frac{3}{16}$ -inch split pin through a small hole drilled through the flange. Manufacture and installation of the clamp is considered to be within the capacity of ships' forces and if diving helmets on board are not already so fitted, the clamp should be made and installed before the diving helmet is used.

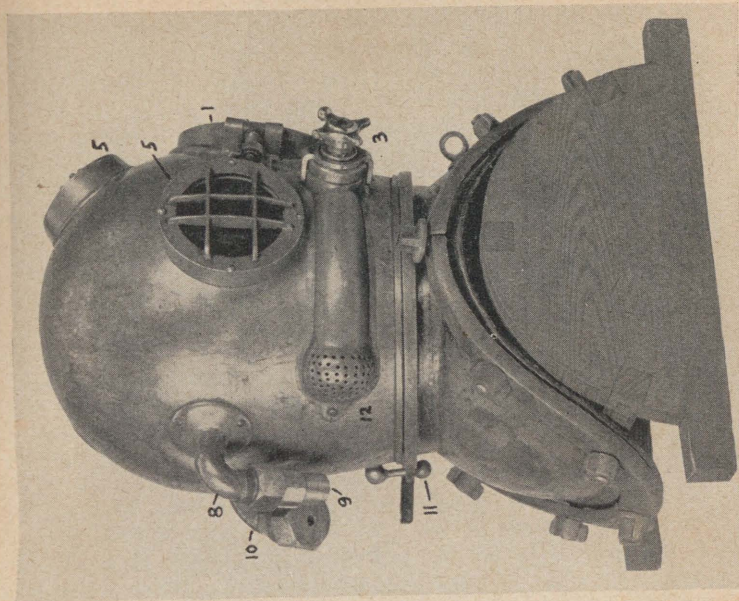

PLATE 24A.—Diving helmet, Mark V, Mod. I—Side view.

10. Gooseneck, Telephone
11. Lever, Safety
12. Regulating Exhaust Body

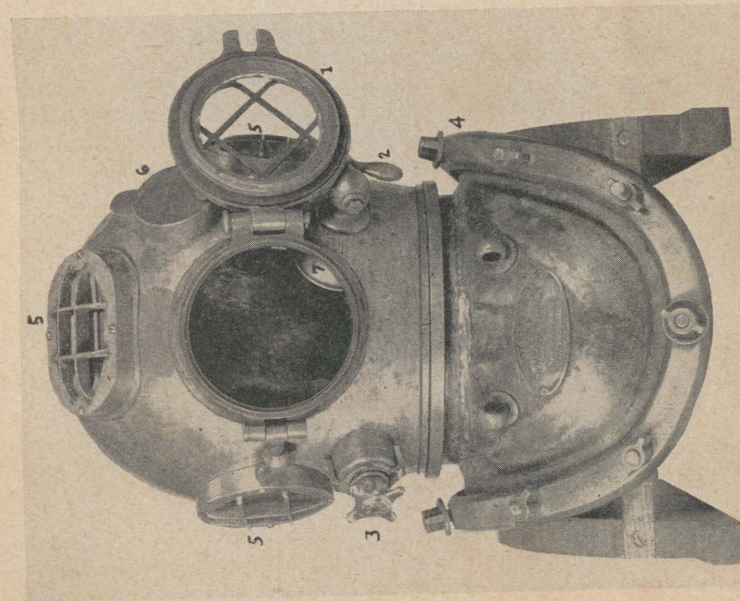

PLATE 24.—Diving helmet, Mark V, Mod. I—Front view.

4. Breastplate
5. Windows
6. Telephone Recess

1. Front Window Door
2. Spig Cock
3. Regulating Exhaust Valve

7. Telephone
8. Gooseneck, air hose
9. Valve, Safety non-return

The helmet is fitted with four windows. The one directly in front of the diver's face is called the faceplate. The faceplate is hinged and is held in a closed position by means of a swinging bolt and wing nut secured to the helmet and acting through two lugs on the faceplate. The wing nut of the bolt when screwed down fits into a countersunk recess in the two lugs of the faceplate, thereby preventing slippage or accidental displacement of the bolt from the faceplate. The countersunk recess referred to should be in the faceplate of all diving helmets. If the faceplate on any diving helmet in service is discovered to be without this feature, it should be countersunk by the ship's force before the helmets are used. The joint made by the faceplate flange and the helmet, when the faceplate is closed, is made watertight by a rubber gasket.

The other three windows of the helmet are located as follows: one on each side of the helmet on a level with the faceplate to enable the diver to see laterally; and the third on the midline of the helmet above the faceplate to allow upward vision. The side and top glasses are glazed in and made watertight by red lead, held securely by gun-metal frames. The glasses of all windows and the faceplate are protected against breakage by gun-metal gratings.

An air-inlet connection is located at the back of the helmet and to the right, and is curved downward to give the proper lead to the diver's air hose. The air safety or nonreturn valve (pl. 26) is screwed onto the end of this gooseneck and the air hose in turn is coupled to the male-threaded portion of the valve. The air hose is then led under the diver's left arm and connected to the air-control valve located on the front of the suit. The proper functioning of the safety or nonreturn valve is of utmost importance. Its purpose is to prevent the diver from being injured by "squeeze" in the event that his air hose bursts or the air supply system becomes so seriously damaged as to fail to maintain an air pressure within the dress sufficient to counteract the external water pressure. Under either of these conditions the air pressure in the hose would fall suddenly and if there were no safety valve in place or if it failed to function, the compressed air in the helmet and dress would escape through the air hose. Therefore the pressure within the helmet and dress would become less than the external water pressure. The helmet being rigid and the dress being flexible, the effect of the greater external pressure would be to squeeze the diver's body into his helmet in the same manner as a cork is forced into any empty bottle when lowered into deep water. Even a slight excess pressure under these conditions has been known to be instantly fatal to the diver.

The combination telephone and life-line cable connection is placed to the left at the back of the helmet. The connection is curved downward to give a fair lead for the cable, which crosses the air hose and passes under the diver's right arm (plate 6).

An air-regulating exhaust valve is fitted below the window along the right side of the helmet, together with an escape channel, so that the point of exhaust is toward the rear of the helmet. This position of the exhaust prevents air bubbles from

passing in front of the face plate and obstructing the diver's view.

The purpose of the air-regulating escape valve is to automatically maintain the air pressure in the diving helmet in equilibrium with the outside water pressure and to provide a means whereby the device can regulate the inflation of his dress and consequently his buoyancy. As the diver enters the water, the diving dress is subjected to an external pressure which tends to force the air in the dress up into the helmet and then out of the air-regulating escape valve. If the escape of this air is not retarded, or the air supply is inadequate, the dress will collapse and the diver's breathing interfered with. With a normal air supply and no means to regulate properly its flow from the helmet, too great an inflation of the dress will result and be followed by an excess of positive buoyancy and a consequent "blowing-up" of the diver to the surface. If a diver finds it necessary to increase his buoyancy, he accomplishes this by closing the air-regulating escape valve the necessary amount,

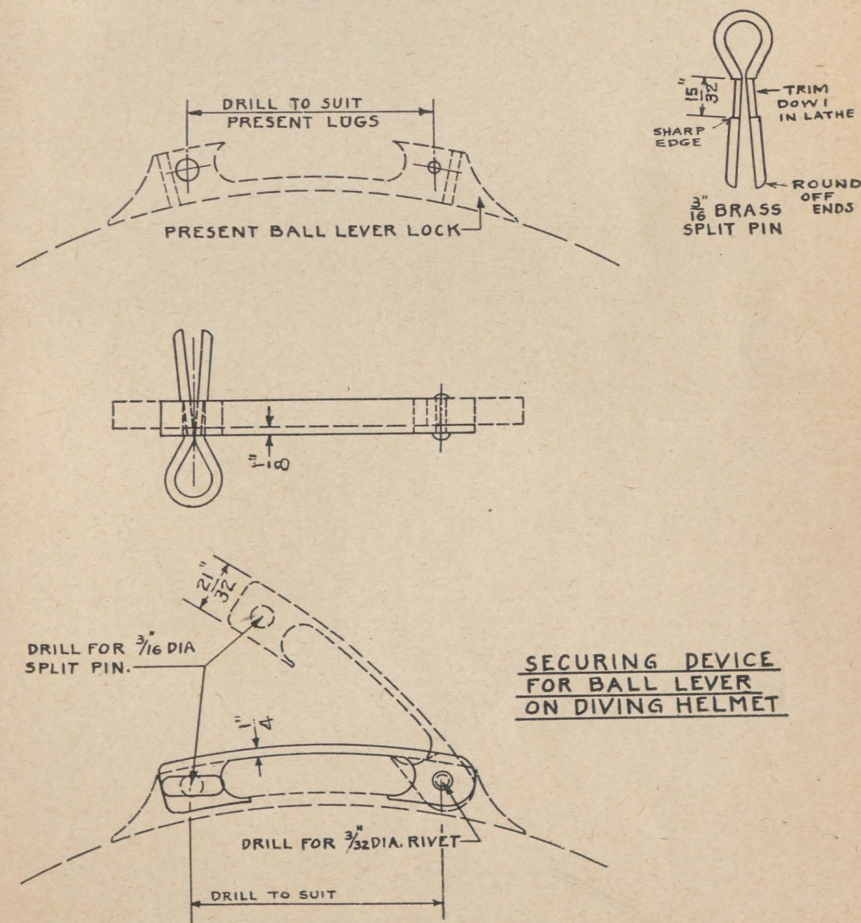
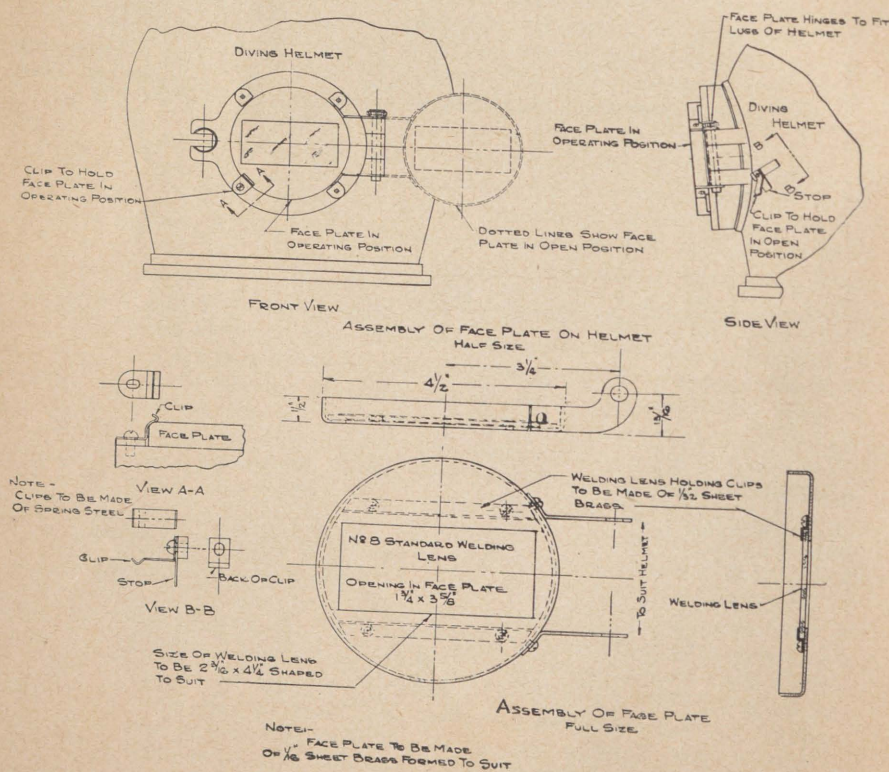

PLATE 25.—Helmet lock.

thus increasing the inflation of his dress. If the danger of over-inflation becomes apparent, he decreases it by opening the valve by operation of the valve chin button. The throw of the valve stem, through the medium of the chin button, should be such as to permit immediate discharge of all excess air. If the flow is insufficient, the only resort in the past has been to cut off the air supply or to adjust further the air-regulating escape valve by operation of the outside regulating screw. This requires an appreciable period of time and meanwhile the over-inflation of the dress may progress to the point where the diver becomes excessively buoyant. At the beginning of "blowing-up" the helmet lifts as far as the jock strap will permit and it is then difficult for the diver to reach the valve chin button with his chin. With the rapidly increasing inflation his arms may become involuntarily distended, with the result that he is unable to reach his air supply valve or the regulating screw of the escape valve.

It is obvious from the foregoing that the air-regulating escape valve is one of the most important features of the diving helmet and a valve of proper construction, principle of operation, and reliability is essential to proper performance of diving work and safety of the diver.



The air-regulating escape valve at present used by the Navy was adopted as standard in 1931. It was designed to overcome the difficulties described above and as constructed the objectionable features of previous type valves have been eliminated. The valve with its constituent parts is shown on plate 27. A description of it follows:

The internal pressure in a diver's dress is normally about  $\frac{1}{2}$  pound per square inch in excess of the external water pressure. The valve is closed against this  $\frac{1}{2}$  pound air pressure by a light spring (K). The outer end of this spring bears against the follower disk (N) which fits into the end of a secondary spring (O). This secondary spring is designed and constructed to maintain a differential tension of 2 pounds per square inch when the valve is fully closed, a condition which exists when the regulating screw is screwed in until the follower disk (N) bears

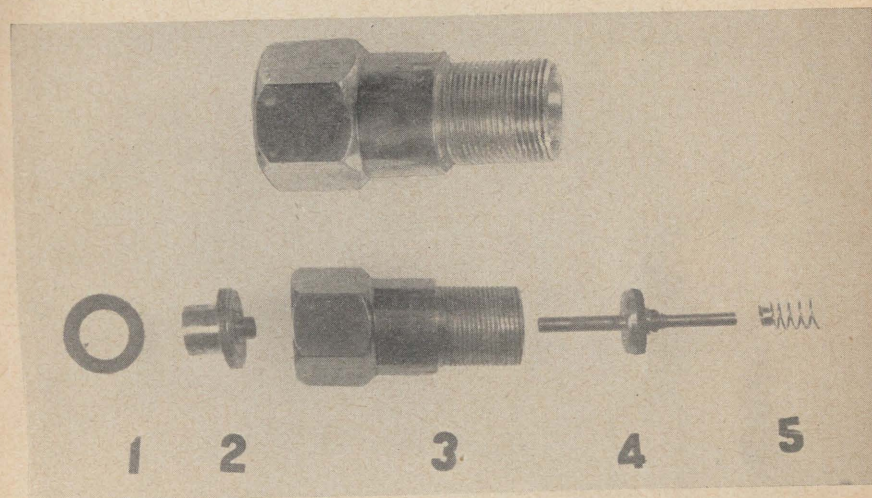

directly against the valve stem adjusting sleeve setscrew (M). The valve stem adjusting sleeve (J) permits the length of the valve stem to be adjusted as desired, so that the exhaust valve may be fitted to any helmet in service, regardless of variations in dimensions that may exist. The sleeve (J) screws on the valve stem (B) and its longitudinal travel in either direction gives the desired setting for length. When the proper setting is obtained, the sleeve is locked in place by the setscrew (M) which screws into a threaded hole in the end of the valve stem. When installing the valve in the helmet, the length of the valve stem should be adjusted so that the disk follower disk (N) comes in contact with the setscrew (M) when the adjusting wheel (G) is about one-eighth of a turn short of the fully-closed position.

When the valve is fully opened, the shoulder on the underside of the chin button (A) strikes against the valve stem guide and thus prevents the chin button from partly closing off the air passage with consequent restriction of air flow.

The regulating screw (F) is provided with a handwheel of improved design which permits a diver who is wearing gloves to grasp it more easily and to estimate the degree of turn more readily than with wheels of conventional type. A dowel pin on the underside of the handwheel strikes against another dowel pin on the bonnet when the valve is in the fully closed position and thus prevents the wheel from continuing its travel until it becomes jammed against the bonnet.

The valve is adjusted by means of the regulating screw (F) and handwheel (G), the normal degree of opening of the valve

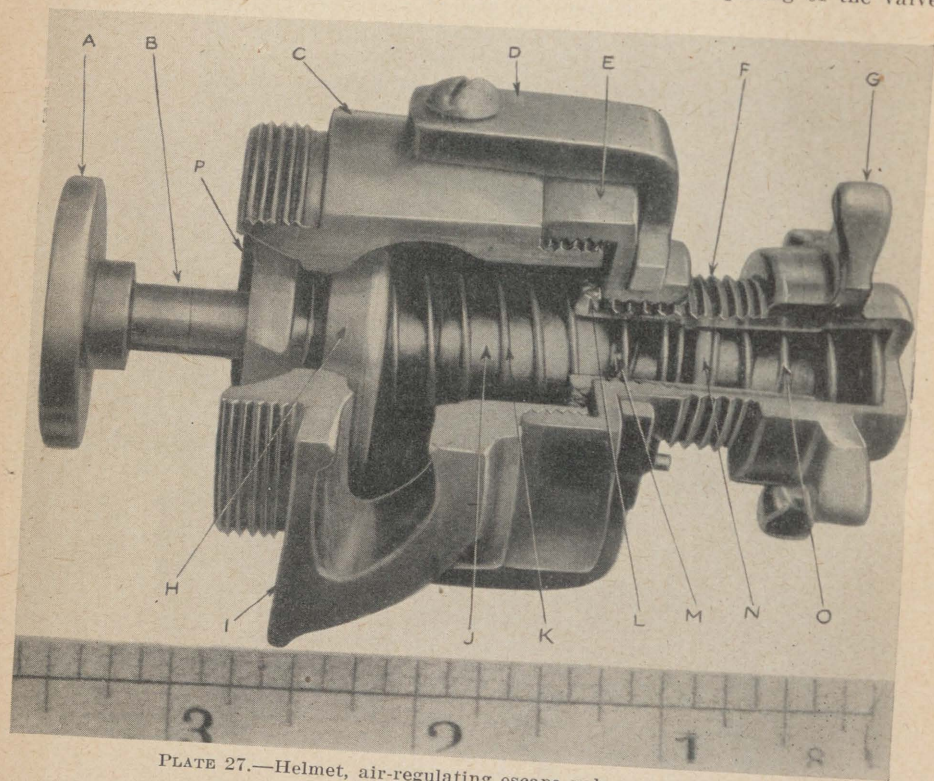

PLATE 27.—Helmet, air-regulating escape valve, assembled.

against the pressure of  $\frac{1}{2}$  pound per square inch spring (K) being dependent upon the clearance which exists between the valve stem adjusting sleeve setscrew (M) and the secondary valve spring follower disk (N). The diver is able to attain any desired degree of air flow through the valve by manipulation of the handwheel. If the clearance between the adjusting sleeve setscrew (M) and the secondary valve spring follower disk (N) is zero, as is the case when the adjusting screw is screwed in as far as possible, the valve is in the closed position and the valve stem is being held against its seat by the 2-pound spring instead of the  $\frac{1}{2}$ -pound spring. It is thus possible to build up an excess pressure of 2 pounds per square inch within

the suit, which is more than sufficient to give the diver any buoyancy required in service. At the same time, no matter what the setting of the regulating screw may be, it is always possible to obtain immediately the full opening of the valve by depressing the chin button (A), for after the  $\frac{1}{2}$ -pound spring is compressed until the setscrew (M) brings up against the follower disk (N), the longitudinal motion of the valve stem may be continued to the maximum degree of travel by compressing the 2-pound spring (O).

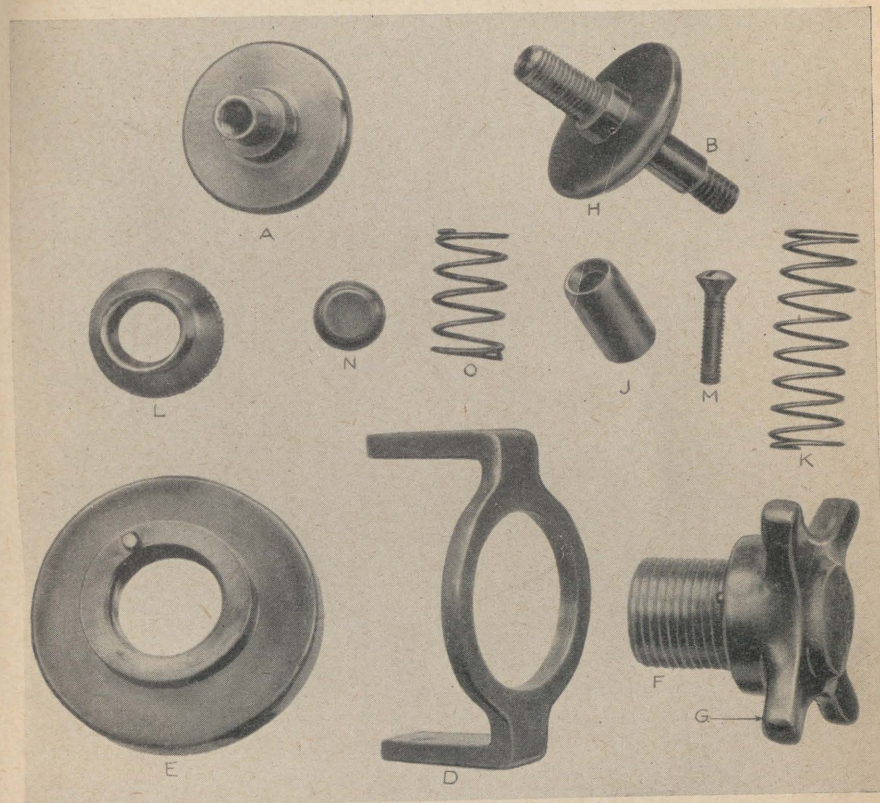

PLATE 27-A.—Helmet, air-regulating escape valve, disassembled.

All parts of the valve are made of corrosion-resisting material. Parts (A), (B), (H), and (J) are Monel metal. Part (N) is of Tobin bronze and parts (D), (E), (F), (G), and (L) are of naval bronze. The springs (K) and (O) are of phosphor bronze.

All diving helmets in service are supposed to be equipped with the standard valve described above, and the initial quantity of valves obtained and issued was sufficient for this purpose. In the old-type valves previously used the bottom of the regulating screw came in direct contact with the end of the valve stem and consequently the extent to which the valve could be opened was limited by the setting of the regulating screw. These old-

type valves, if found on any diving helmets in service, should be removed and discarded and the standard valve installed in their place before the diving helmet is again used.

To install the improved-type valve in the helmet, refer to plate 27 and proceed as follows:

1. Remove old valve from helmet.
2. With the special rotary tool shown on plate 28 cut groove around periphery of the valve seat boss on the diving helmet, the groove to be cut as deeply as the tool permits.
3. Thoroughly clean out shavings.
4. Pieces (G), (E), (D), (N), (O), and (L) and pieces (M), (J), (H), and (A) are delivered assembled. Piece (K) is delivered separately. Unscrew piece (A) and install assembly (L), (I), and (H) in valve housing (boss) on helmet, inserting neck (B) in valve stem guide (P), letting valve (H) seat in valve housing (C).
5. Screw piece (A) to (B).
6. Connect assembly (G), (E), (D), (O), (N), and (L) to valve housing (C) by screwing cap (E) to same.
7. To set valve properly screw valve adjusting wheel (G) in as far as possible.
8. Hold stem assembly (M), (K), (H), and (A) so that valve seats in valve housing (C).
9. If in this position the adjusting set screw (M) just touches piece (N), the valve is properly set.
10. If the adjusting screw (M) does not touch piece (N), adjust it until it does touch.
11. Unscrew piece (E), insert spring (K) and reassemble.

New diving helmets when purchased will have the air-regulating escape valve boss grooved as indicated in operation (2) of the preceding paragraph. If it becomes necessary to groove or regroove helmets in service, the Bureau of Ships should be advised and arrangements will be made to furnish temporarily for this purpose one of the necessary grooving tools. There are only four of these tools at present available in service and the limited number necessitates their being used alternately by ships. The tool is shown on plate 28 and its method of use is as follows:

1. Screw cutting tool (A) in by turning wheel (B) counterclockwise as far as possible.
2. Remove lock screw (C) and release thrust nut (D) counterclockwise 3 turns.
3. Assemble tool (G) to valve housing in helmet securely by using pin spanner wrench (furnished).
4. Be sure tool holder (E) does not bind on valve seat. Release thrust nut (D) farther if necessary.
5. Screw in thrust nut (D) so that tool holder (E) touches valve seat.
6. Release thrust nut (D) 3 notches to obtain proper clearance.
7. Replace lock screw (C).
8. Screw feeding wheel (B) in until tool starts cutting; turning crank (F) clockwise one complete revolution for each cut.
9. Turn feeding wheel (B) one notch at a time (indicated by audible click).

10. Repeat operation until tool cuts groove as deeply as tool permits.

11. Do not turn crank (F) counterclockwise as this will dull cutting edge of tool.

12. Screw cutting tool (A) back in, as far as possible by turning feeding wheel (B) counterclockwise, before removing tool from valve housing.

13. Thoroughly clean out shavings of cutting tool before installing safety air-escape valve.

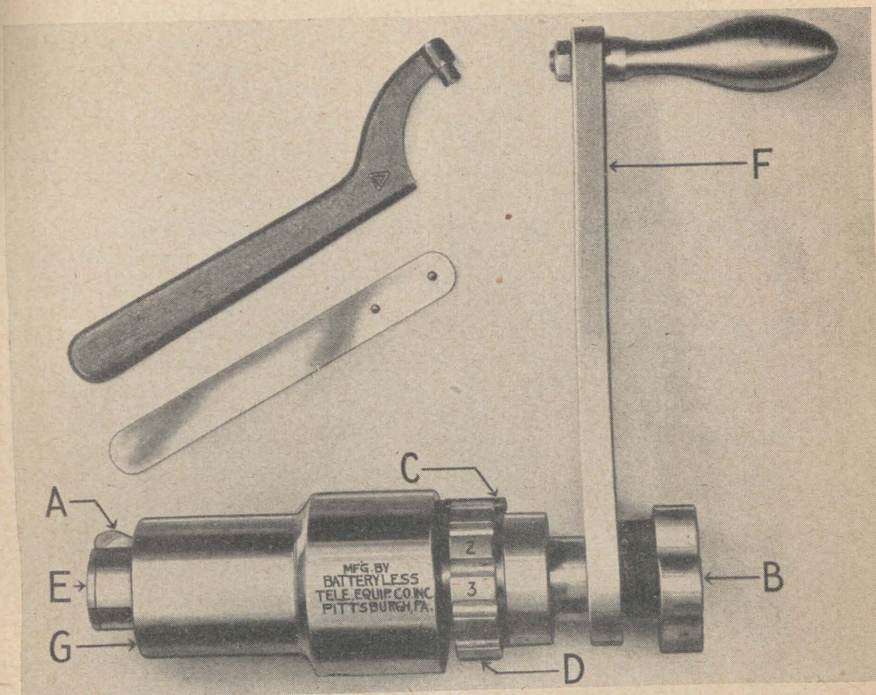

PLATE 28.—Grooving tool for installing air-regulating escape valve.

A supplementary relief valve (spit cock), part 2, plate 24, is located diametrically opposite the air-regulating escape valve. This valve is operated by the diver by means of a lever-type handle and not only permits a fine adjustment of his buoyancy but also the expulsion of water which may have collected inside of the helmet by the bib of the dress.

The diver's telephone transmitter (if of old battery type) or combined receiver and transmitter unit (if of amplifier type) is secured inside the helmet above and to the left of the faceplate. Also inside the helmet an air inlet channel is sweated to the top of the helmet with branches leading to and terminating just over the top and side windows to deflect the incoming air from the diver's head.

Plate 25-A shows an auxiliary fitting for the standard diving helmet, which consists of a metal frame, containing "Noviol" glass and a means for attaching it in front of the helmet face

plate to filter out the bright rays of light when underwater cutting or welding work is being performed. These frames are issued only with the No. 1 outfit, however, they can easily be manufactured at the navy yards. Further details on this subject are covered in this chapter under "Lights and underwater illumination."

The breastplate, part 3, plate 24, is that portion of the diving suit which connects the helmet to the diving dress. It is made of the same metal as the diving helmet and is shaped so that its lower portion fits comfortably over the shoulders, a cushion, figure 3, plate 20, being interposed between the shoulders and the breastplate. Twelve screw studs and four metal straps are provided for attaching the diving dress. The straps are held down against the rubber gasket of the diving dress by eight small and four large wing nuts. Located on the front of the breastplate are two metal eyelets to which the life line and air hose are stopped on their respective sides.

The diver's air hose, plate 29, is of a sinking type, having an internal nominal diameter of one-half inch and external diameter of  $1\frac{1}{16}$  inches, with a permissible manufacturing tolerance of plus or minus  $\frac{1}{32}$  inch. It consists of a vulcanized rubber tube reinforced by three plies of braided cotton reinforcement laid on the bias to prevent the hose from wriggling, twisting, or turning, while under pressure. The reinforcement is well embedded in a rubber compound to protect it from chafe or wear. The hose is furnished in both 3-foot and 50-foot lengths. The 3-foot lengths are used for the special purpose of connecting the air-control valve to the air safety or nonreturn valve at the diver's helmet. The ends of each length of air hose are capped with a rubber compound  $\frac{1}{16}$  inch thick to prevent moisture coming in contact with the cotton reinforcement. The tensile strengths of the rubber tube and rubber cover of the hose when new are 1,400 and 1,200 pounds per square inch, respectively. Diving hose when manufactured is required to withstand working pressure of 500 pounds and a bursting pressure of 2,000 pounds. In addition, representative samples are required to withstand a hydrostatic pressure of 1,000 pounds per square inch without bursting. At a point approximately 4 feet from each end of the 50-foot lengths of diving hose is located a molded brand of distinctive color containing the word "Divers'." A similar brand appears midlength of the 3-foot sections of hose. For details as to the life of diving hose and its care and maintenance see chapter VI. Diving air hose is provided in 50-foot lengths. In connecting up the lengths it should be remembered that the length of hose nearest the diver will be subjected to the least difference in pressure, and, therefore, if there is any preference, the best hose should be on the end nearest the surface.

The various air-hose fittings are shown on plates 29, 30, 31, and 32. The ends of each length of air hose are fitted alternately with male and female couplings. These couplings are machined from bars of naval brass. The couplings and clamps are made in accordance with the design and dimensions shown on plate

Hose, air,  
diver's.

Hose, air,  
couplings and  
clamps.

30. In fitting the couplings on the hose, three clamps are slipped over the end of the hose; then the shank of a coupling is coated with rubber cement and forced into the bore until its shoulder is against the end of the hose. The hose clamps are next placed into position, a small thin copper washer being placed under each screw hole to prevent the clamp screws from cutting into the rubber cover of the hose; then the first clamp is set into the vise. Screwing up on the vise compresses the clamp and thus brings the screw holes in line. The clamp screw is then screwed in place and the operation repeated on the next clamp. As the

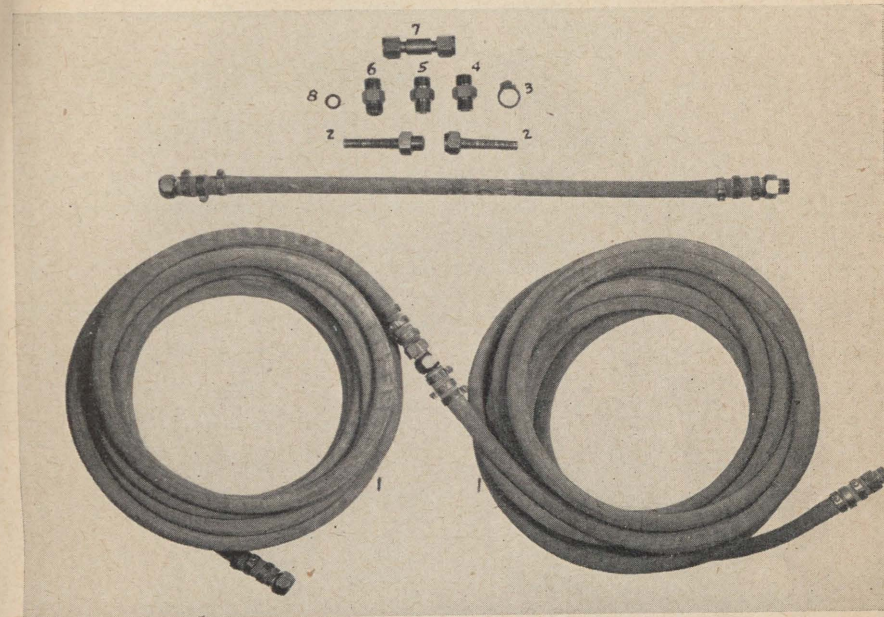

PLATE 29.—Diving air hose.

shank of the coupling is slightly larger in diameter than the bore of the hose and as the clamp is smaller than the external diameter, forcing the hose onto the corrugations of the shank and gripping tightly with the clamps will insure the coupling a firm hold on the end of the hose. A firm hold is absolutely necessary in view of the serious consequences that would result should a coupling pull out of the hose when a diver is under water. The joints between male and female parts of the hose coupling are made watertight by means of leather washers. Double male and female standard air-hose couplings are provided for use when it is desired to make a special connection, i. e., when the alternations of male and female connections are not continuous.

Diving air-hose reducers (adapters) are shown on plate 31. The reducers are furnished in two sizes; viz., type "T" and type "S." The type "T" reducer has one end cut with a submarine male thread and the opposite end with a Navy standard male torpedo-air-pipe thread. The type "S" reducers have one end

Hose, air,  
reducers.

threaded with a submarine male thread and the opposite end threaded with a United States standard iron-pipe-size thread. The type "T" reducers are used for connecting diver's air hose to torpedo charging lines when torpedo charging air is used for the diver's air supply. The type "S" reducers are used for connecting diving air hose to the low-pressure air line on submarines, should it be necessary to utilize the air system on such vessels for diving air.

Knives, divers'.

The latest type of diving knife is shown on plate 33. The blade is made of cutlery grade corrosion-resisting steel, bayonet

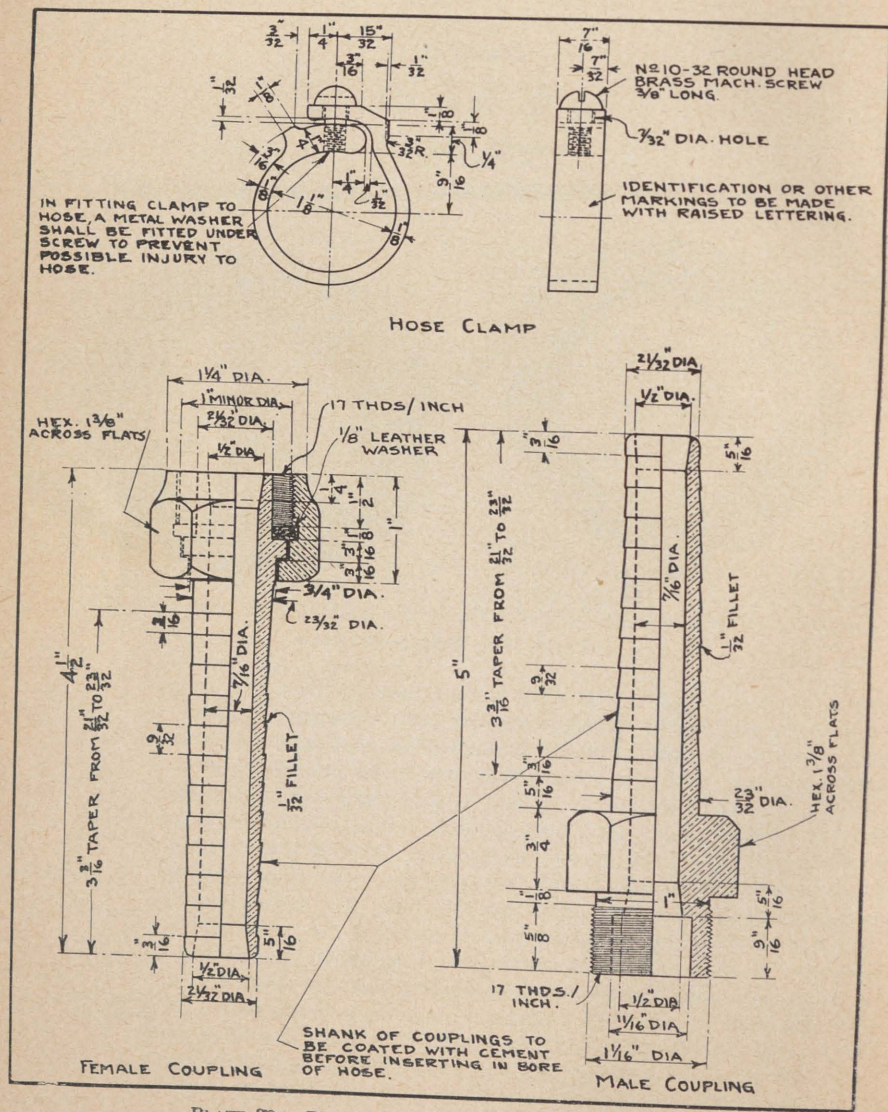

PLATE 30.—Diving air hose couplings and clamps.

shaped, with one edge sharpened for cutting and the other toothed for sawing. The sheath is of brass, cylindrically shaped with a conical bottom. The bottom of the sheath is drilled with a 1/4-inch diameter hole to permit the entrance of water and maintain negative buoyancy of the knife. The top end of the sheath

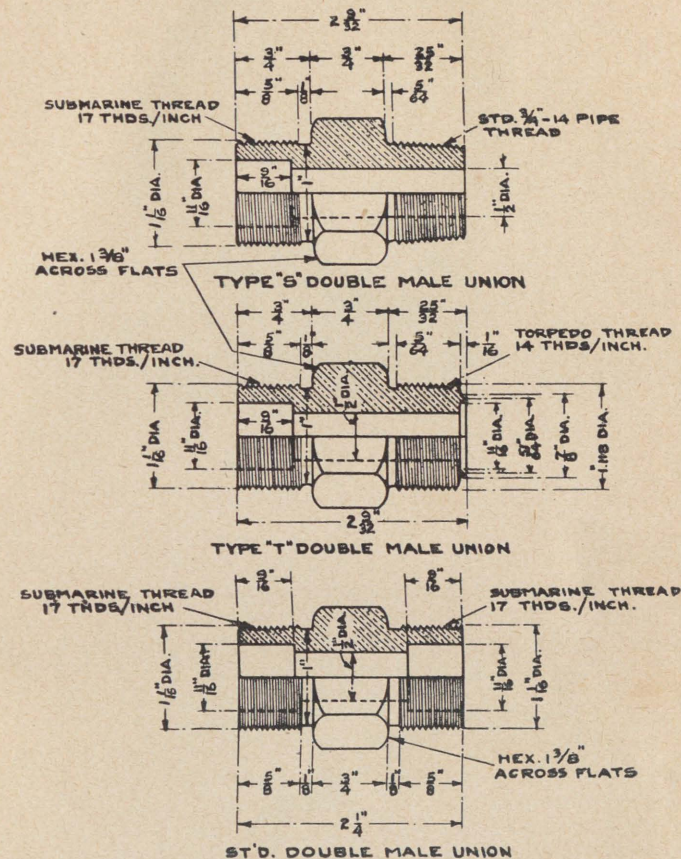

PLATE 31.—Diving air hose special fittings.

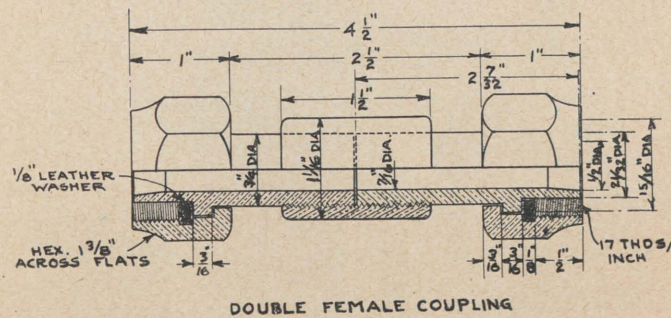

PLATE 32.—Diving air hose double female coupling.

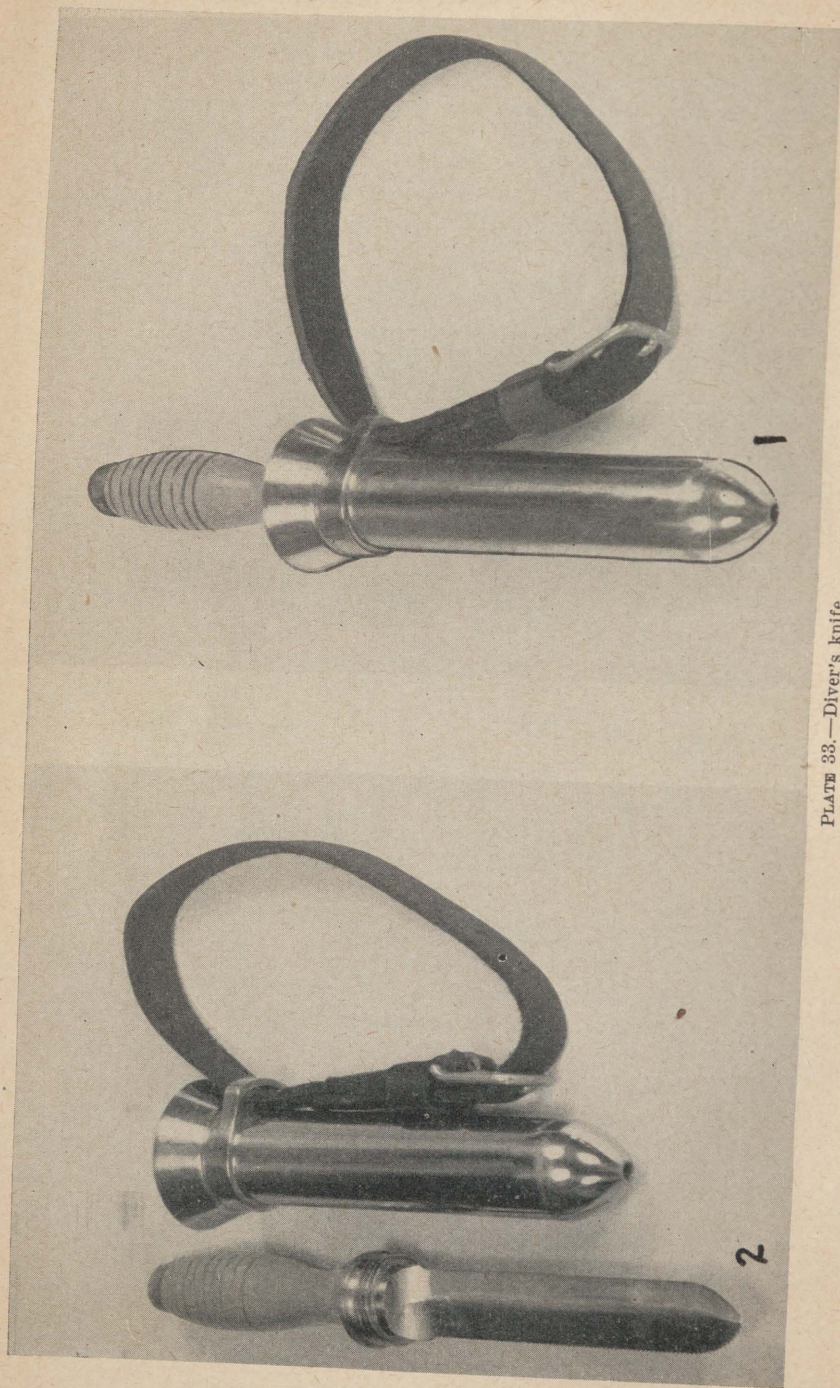

PLATE 33.—Diver's knife.

is threaded to take the threads on the hilt of the knife blade. The handle of the knife is made of maple, chafed as shown with small lateral grooves forming equally spaced corrugations to contribute to firm handhold. The handle is designed to be balanced so that the knife if dropped any distance will fall point first. The handle nut and the sheath nut are made of brass. A leather belt 1 inch wide by 24 inches long and  $\frac{5}{32}$  inch thick, with brass knuckle, completes the assembly.

Prior to adoption of the standard diving knife illustrated therein, the flat sheath bayonet type of knife was used. However, in several salvage operations considerable difficulty was experienced by the divers in sheathing the knife and loss of the blade was a common occurrence. Considerable experimentation was conducted on various types of knives before adoption of the present standard knife illustrated herein. It has been found that blades will frequently break when used for prying, and in order that the knife, other than the blade, will not be discarded, a stock of spare blades is maintained at the distributing yard.

The diving ladder, plates 34 and 35, is designed for use over the side of motor launches. It is adjustable and may be used to fit either 36, 40, or 50-foot launches. The strut that gives the correct inclination of the ladder when in use may be folded in the ladder after removal of the securing bolts, thus facilitating stowage. The ladder is made of wrought iron and is heavily galvanized.

Ladder, diving.

Probably the greatest handicap experienced by divers is reduced vision under water, which may range from 0 to 50 percent normal, depending on the turbidity of the water. On extremely muddy bottoms, with attendant mud and silt in suspension, the diver works in almost total darkness and under such conditions has to depend mostly on his sense of touch for identification of objects.

Lights, diving and under-water illumination.

The extent of light penetration or diffusion of light under water depends principally on the amount of opaque matter suspended in the water inasmuch as the opaque matter reflects the light back to its source. This condition is largely responsible for the limited radius of diffusion of light under water. Increasing the power of the light increases the intensity of illumination but does not materially increase the radius of diffusion nor does the use of reflectors to project the rays contribute materially to greater penetration. Reflectors are, however, beneficial in protecting the diver's eyes from the glare of the light at its source.

While the radius of diffusion of light is governed by the clarity of the water, discernibility under water is considerably contributed to or hindered by the color of the object being observed. Brightly colored objects are more clearly seen by the naked eye or through ordinary glass than dark objects. This has been substantiated by tests recently conducted by the Navy, the results of which definitely indicated that in underwater artificial illumination, dark-colored objects may be discerned in more detail if the bright (glaring) rays of the artificial light are filtered out. The results of some of these experiments are as follows:

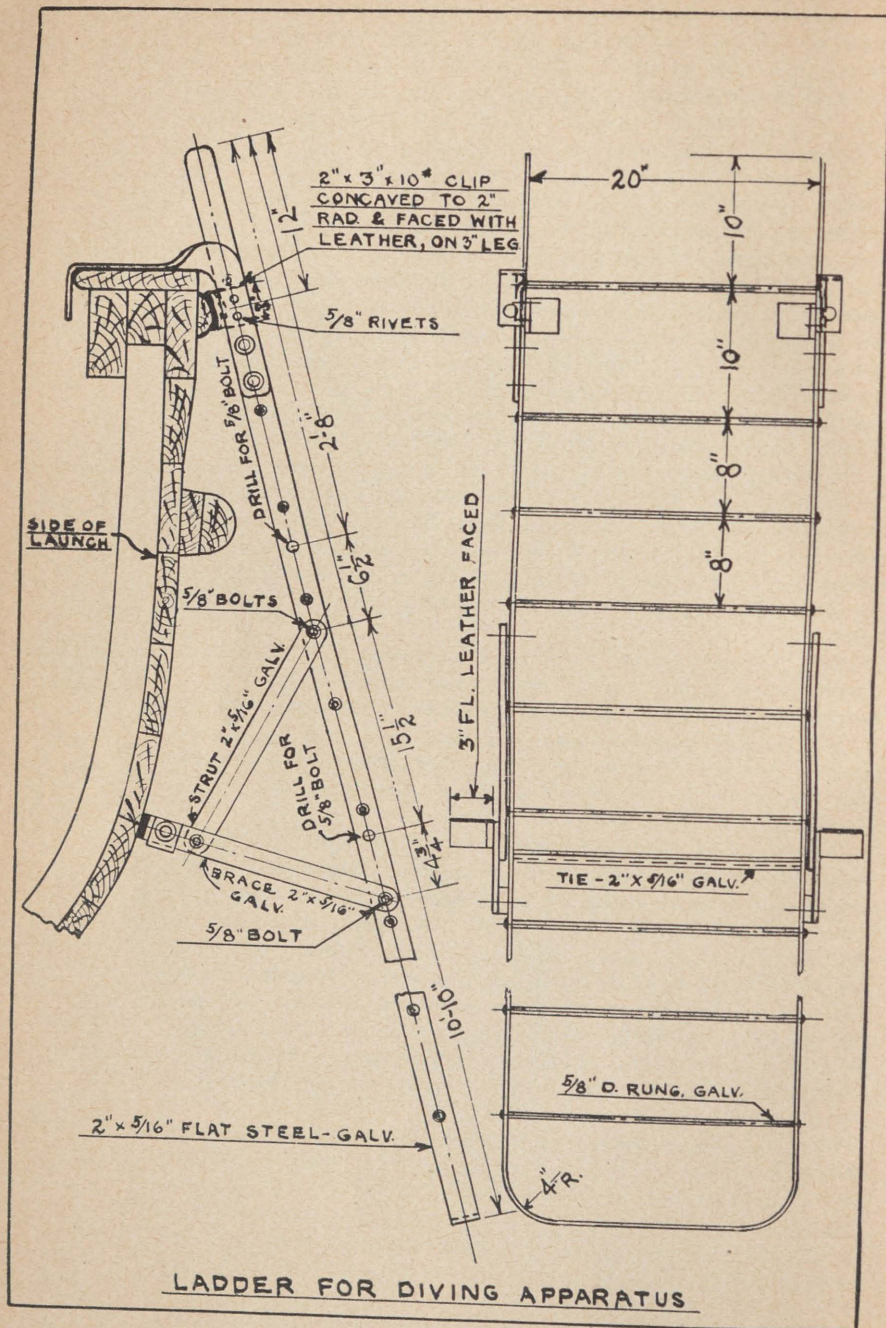

PLATE 34.—Diving ladder.

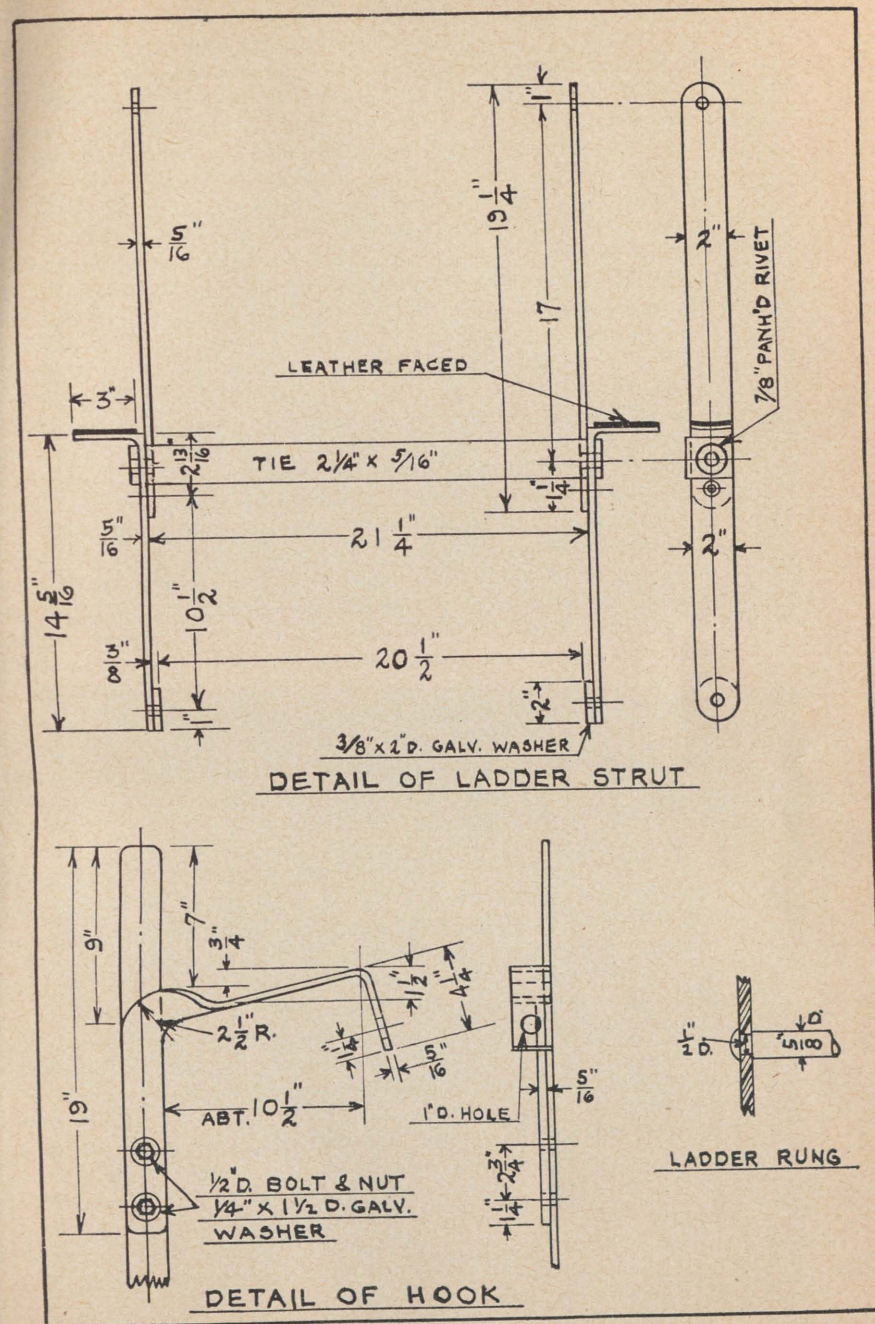

PLATE 35.—Diving ladder details.

Preliminary experiments were first conducted in the water diving tank of the experimental diving unit, where submerged objects, illuminated with a 250-watt clear incandescent lamp, were viewed through the observation port, both with filters in line of vision and removed. It was found that only those filters, the maximum transmission of which was in the yellow or orange, were of value. Filters in the greens and blues were detrimental to good vision. Of this series of filters three were chosen for extended observations; namely, Corning Glass Co., No. 338 "Noviol," shade C (lemon yellow), shade No. 246 (amber), and shade HR red (orange red). These filters were used by a large number of divers in the diving tank and in the river, and of the three shades, the "Noviol," shade C, was found to improve discernibility the greatest extent. To insure that the diver's findings were actually physical and not psychological, a corroded steel plate with holes punched in it and nuts and bolts attached was submerged in the tank in such a position as to be visible through an observation port. The plate was then illuminated by a source of radiation so placed that through the port it was not visible to the eye or camera. Fourteen photographs were taken under constant conditions of turbidity, distance, and times of exposure. The results are reproduced on plates 36 to 49, inclusive. In plates 36 to 42, inclusive, the submerged object was placed 30 inches from the observation port and the source of illumination placed 20 inches from the object. Plates 43 and 44 show the appearance of the submerged plate after it had been moved 60 inches from the observation port with the source of light 50 inches from the object. Plates 45 to 49, inclusive, show the plate after water in the tank had been changed and the plate moved again to within 30 inches of the observation port. The sharpness of the details of the corroded plate with its nuts and bolts as shown on the respective photographs was then taken as a criterion of the value of the type of illumination used.

Plate 36 shows the corroded steel plate in the tank illuminated with a 250-watt "Photoflood No. 1" lamp placed in the diving lamp casing with no optical filters in the light path. To the eye, the intervening water appeared to be filled with a bright haze due to the light scattered by the suspended matter. This bright haze confused very markedly the vision of the person looking into the observation port. The sharp edges of the punched holes, the slots in the bolt heads, and the edges of the nuts became less distinguishable. However, after exchanging the clear bulb in the lamp for a 250-watt amber-colored bulb, the bright haze between the observer's eye and the submerged object became much less and the details of the plate stood out more clearly. Plate 37 shows the photographic effect of this type of illumination.

The amber bulb was next replaced with a 250-watt "Photoflood" lamp No. 1 and an optical filter made of Corning No. 246 glass placed in front. This glass is a yellowish amber color. Plate 38 exhibits the appearance of the object under water when illuminated by the radiation through the No. 246 glass. The bright scattered light was absent and the details of the plate

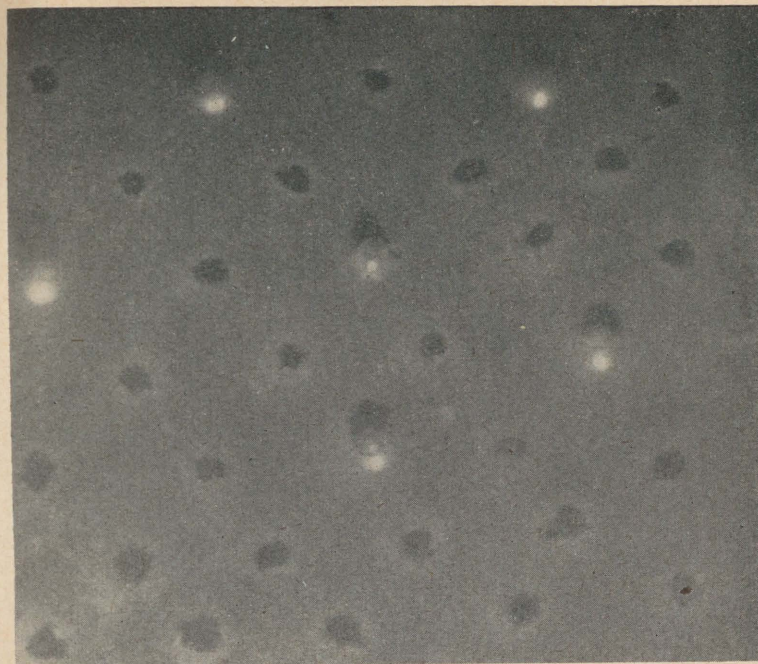

PLATE 37.—Under-water visibility.



PLATE 36.—Under-water visibility.

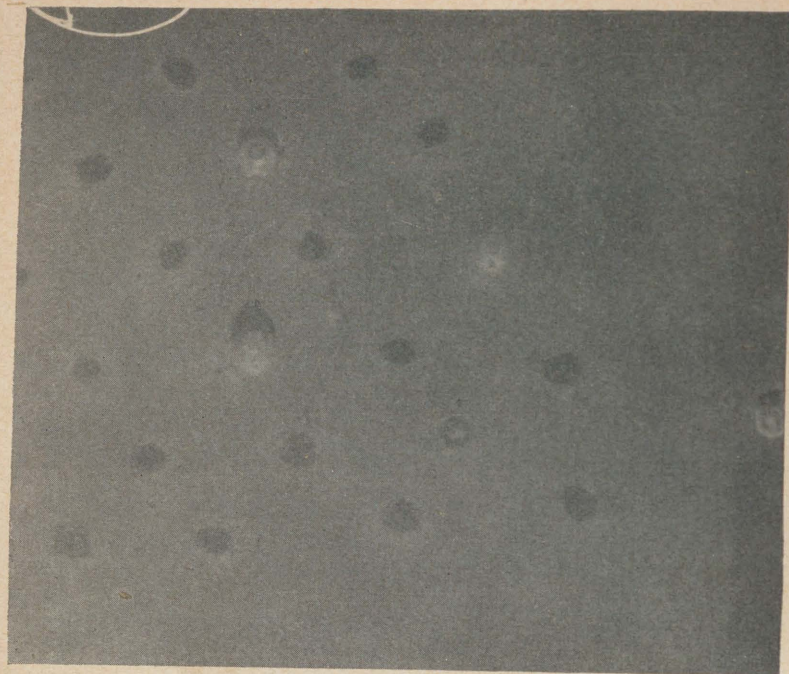

PLATE 39.—Under-water visibility.

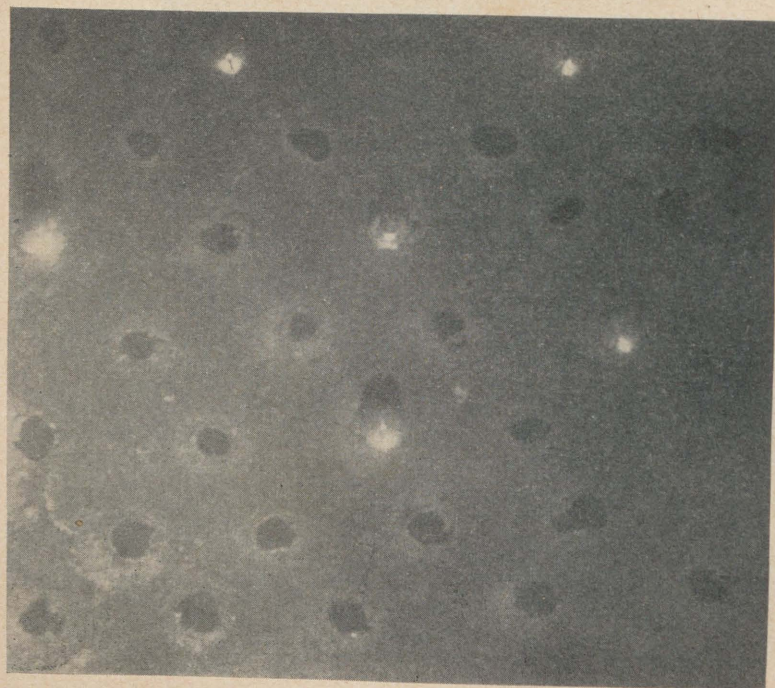

PLATE 38.—Under-water visibility.

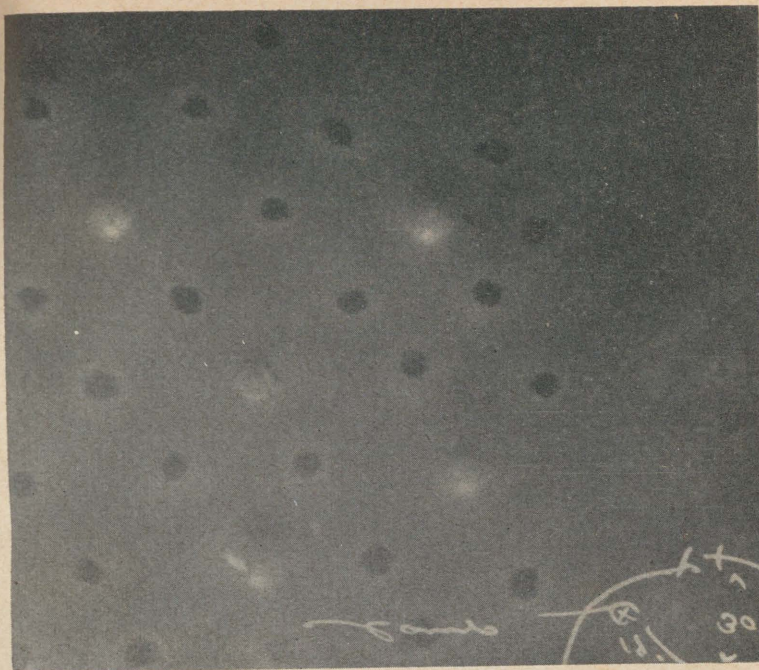

PLATE 41.—Under-water visibility.

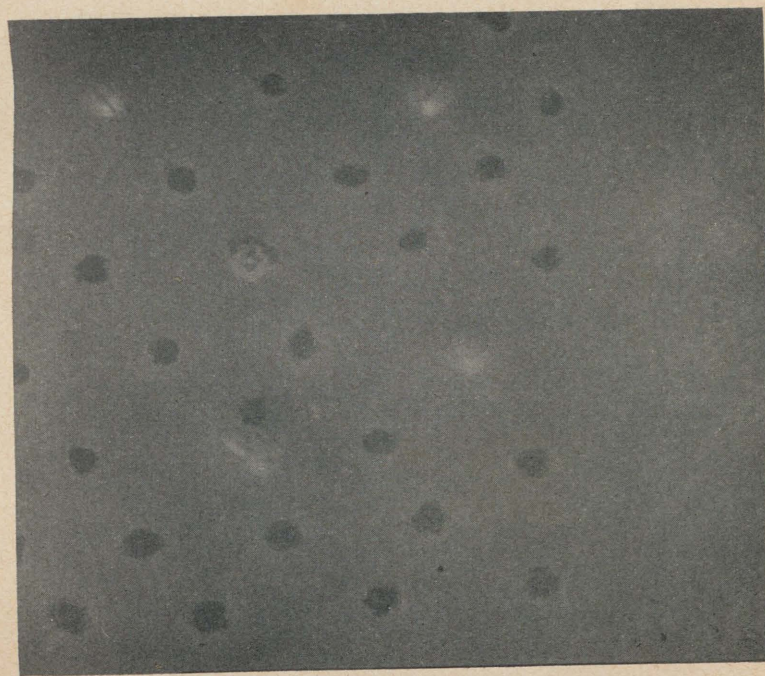

PLATE 40.—Under-water visibility.

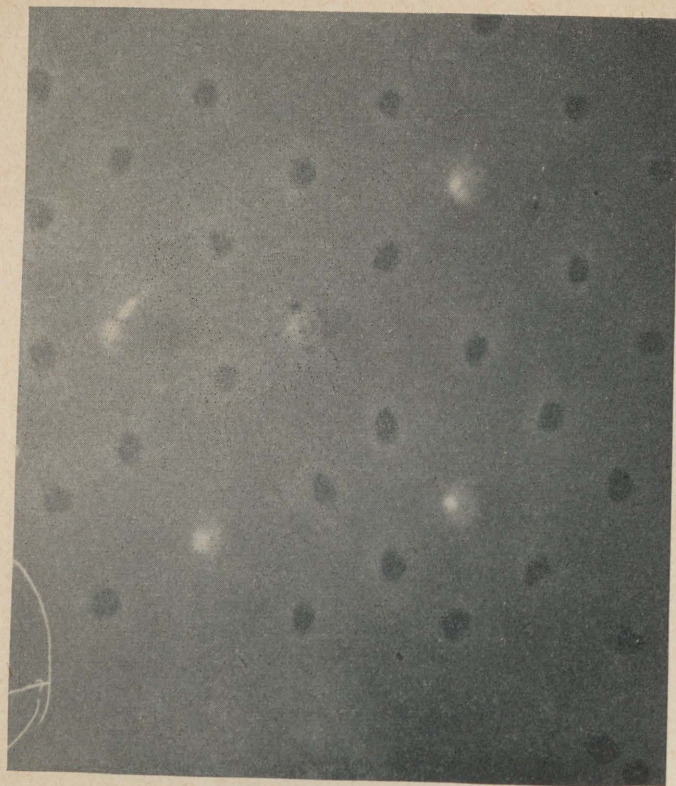

PLATE 42.—Under-water visibility.

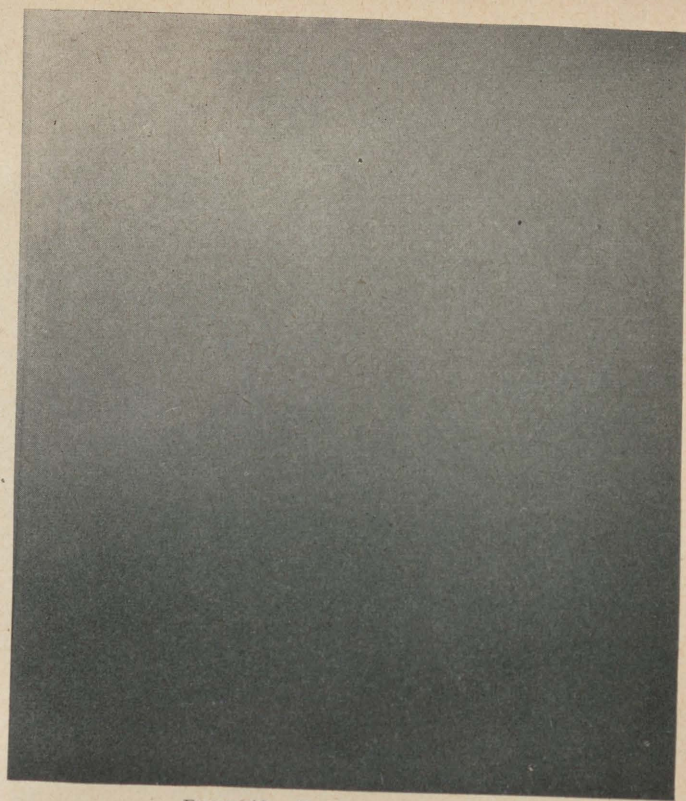

PLATE 43.—Under-water visibility.

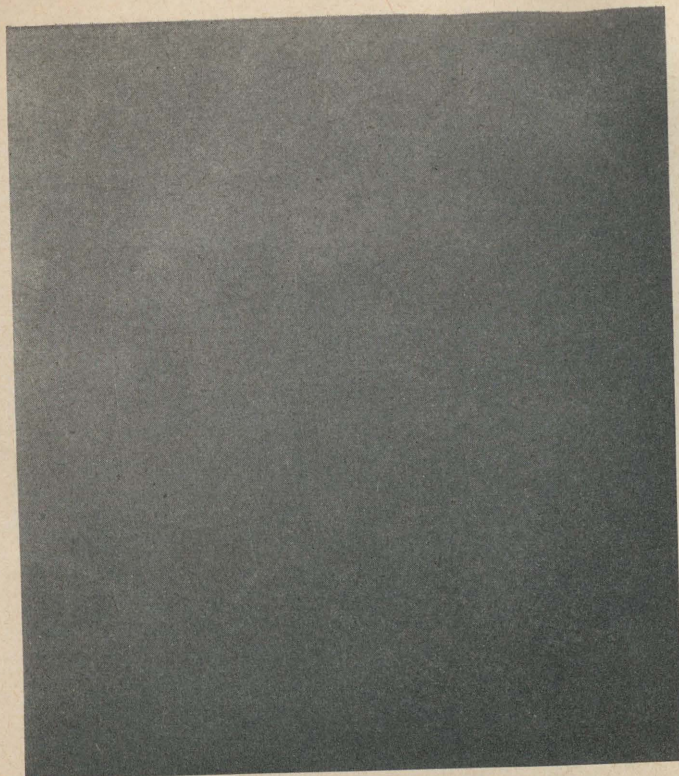

PLATE 44.—Under-water visibility.

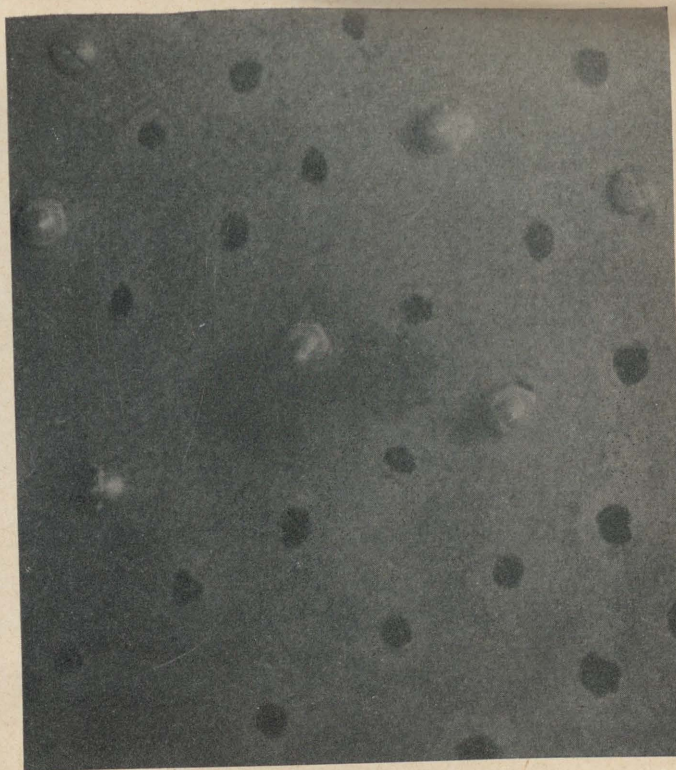

PLATE 45.—Under-water visibility.

646428—45—5

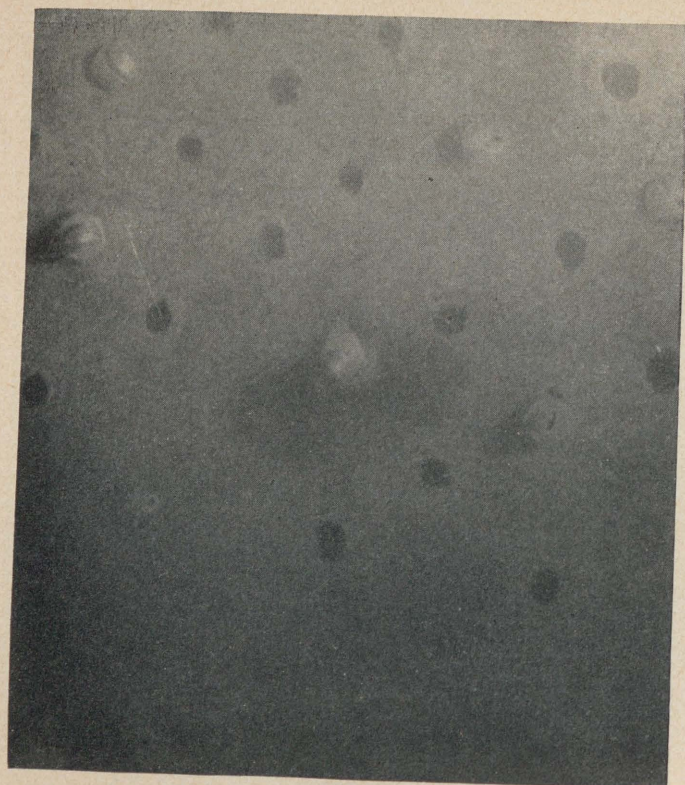

PLATE 46.—Under-water visibility.

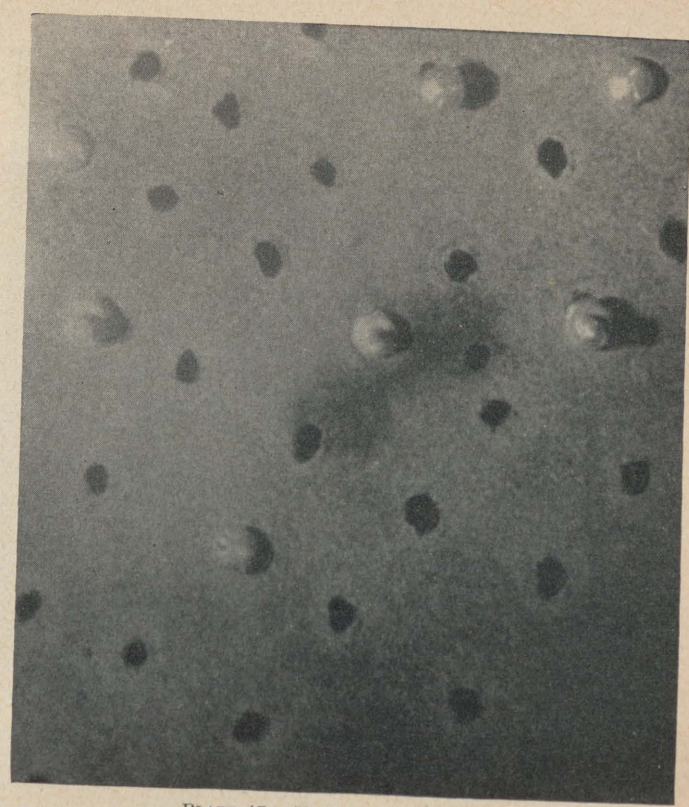

PLATE 47.—Under-water visibility.

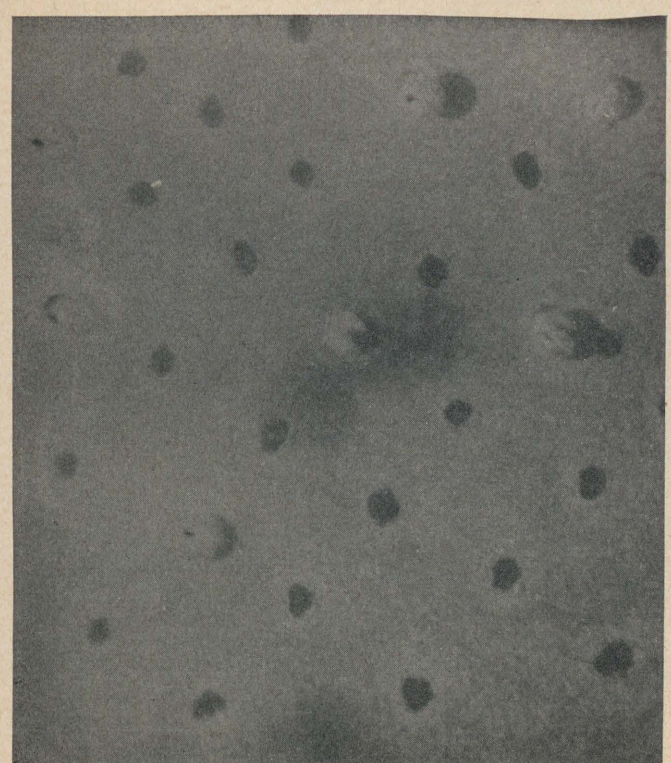

PLATE 48.—Under-water visibility.

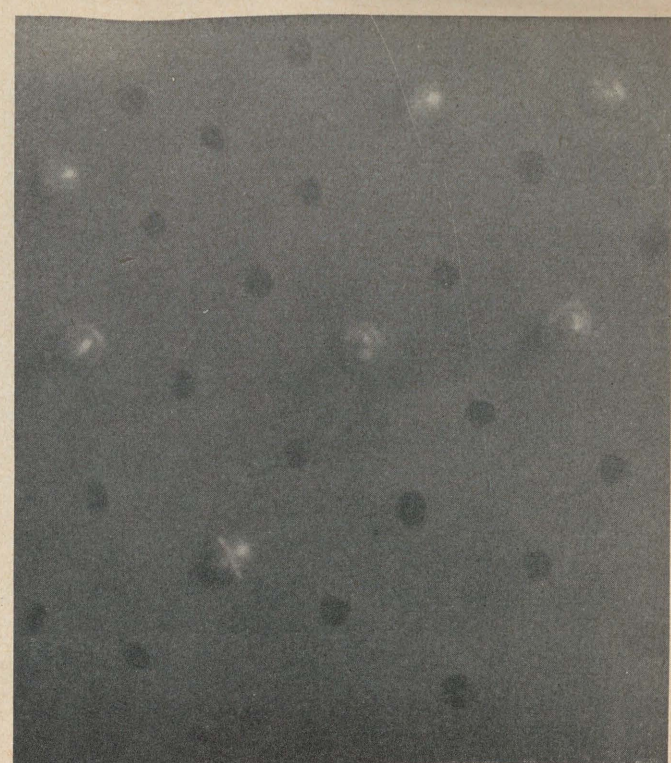

PLATE 49.—Under-water visibility.

stood out quite clearly. Plate 39 shows the plate when illuminated with the same 250-watt "Photoflood" lamp No. 1 with a Corning "Noviol" shade C (lemon yellow) filter interposed between the lamp and the plate. Again the mass of scattered light was absent and the details of the plate appeared to become more discernible.

Plates 40, 41, and 42 were taken with the submerged plate illuminated by the clear bulb "Photoflood" No. 1 lamp placed in the casing of a Navy standard diving lamp and the optical filter placed before the lens of the camera. Plate 40 shows the effect of the Corning "Noviol" shade C, plate 41, Corning No. 246, and plate 42, a filter made of reddish amber-colored glass known as Corning HR red. Visual observation and photographic examination indicated that from an optical standpoint it makes no difference in the results, whether the filter is placed in front of the lamp or held before the eye.

Plate 43 shows the submerged plate when it was moved back from the port to a distance of 60 inches and illuminated by the clear 250-watt lamp placed 50 inches from it. The water contained considerable suspended matter, due to the activities of the divers working in the tank. The silt was allowed to settle until a constant condition of turbidity was reached before the photograph was taken. When the plate was observed through the port illuminated by the clear lamp, the scattered light was so intense that the eye was blind to such an extent the details of the plate were quite indistinct. Three filters, namely, Corning "Noviol" shade C, Corning No. 246, and Corning HR red, were in turn placed before the diving lamp. In each case the bright scattered light became much less pronounced and the details of the plates became more distinguishable, although of course much less so than when the plate was 30 inches from the port. Plate 44 shows the plate when illuminated by radiation from the clear lamp which had passed through the "Noviol" shade C filter. With this illumination the nuts and bolt heads were more clearly seen.

Plate 45 shows the appearance of the submerged plate when illuminated with a large General Electric sodium vapor lamp enclosed in a watertight casing. To the eye the plate and its details were very clearly visible and the scattered light between the observer and the object did not appear to be very intense. Plate 46 shows the submerged plate again illuminated with the radiation from the sodium light with an Eastman K-3 filter in front of the camera lens.

Plate 47 shows the submerged object again illuminated by the clear lamp in front of which was filter of Corning "Noviol" shade C. A comparison of plates 46 and 47 shows the two sources of illumination to be about of equal value, which observation is supported by visual trials. In plate 48 an Eastman K-3 filter was placed in front of the camera lens with no noticeable effect.

Plate 49 shows the submerged plate illuminated by radiation from a high-powered G. E. mercury vapor lamp enclosed in a watertight casing. As was expected, to the eye the details of

the plate were quite indistinct, since the eye loses its sensitivity quite rapidly as the wavelength of radiation decreases; and, as is well known, the mercury arc is rich in radiation in the blue region. The photographic plate, which is sensitive to the lower wavelengths, would be expected to show about as much contrast as with other types of illumination.

While these tests definitely established the fact that where clarity of water is such as to permit light penetration, an optical filter with maximum transmission in the yellow materially improves the discernibility of submerged objects by the diver. On the other hand, when the quantity of sediment in the water exceeds a certain value, optical filters are of no value. So far as concerns their use under conditions attendant on Navy diving, sodium vapor and mercury lights offer no advantage over the Navy standard diving light.

As a result of the above experiments, an optical filter of "Noviol" shade C glass, fitted in a frame, plate 25-A, which can be readily attached to the faceplate of the diving helmet, has been adopted for use in work involving underwater cutting and welding.

The diving light adopted for Navy use is the result of development through several actual salvage operations. The light consists of a 1,000-watt lamp, a lamp holder of seamless brass tubing, and a chromium-plated copper (20 B. & S. gage) reflector fitted with a wire-meshed guard. The lamps are made of special glass designed to withstand pressures equivalent to those at 500-foot depths. The lights are of two types as illustrated on plates 50 to 53, inclusive. The light shown on plates 50 and 51 is known as the Westinghouse type. That shown on plates 52 and 53 is known as the Morse type. The Westinghouse type reflector is cylindrically shaped with a dome top, the diameter at the base being approximately 11 inches, whereas the Morse type is parabolical in shape and with a base approximately 10 inches in diameter. The reflectors of both types are mounted on a cylindrical nonwatertight metal sleeve fitted at the outer end with a nut and rubber bushing for securing the lamp and cable. The Westinghouse lamp is tailed with a 3-foot length of twin conductor cable forming an integral part of the lamp unit. The lamp unit is taped with rubber insulating tape to form a watertight assembly which is housed by the metal sleeve referred to above. The lamp with the 3 feet of cable taped as described is issued assembled as a unit. When in use, the free end of the 3-foot section of cable forming a part of the unit is spliced and taped to twin conductor cable of the length required for a particular diving operation. In replacing the lamp with the 3-foot section of cable, the locking nut on the end of the sleeve of the light is backed off, and the lamp unit in its entirety removed from its housing. In the Morse type light the 3-foot length of cable is secured at the reflector end to a threaded receptacle which accommodates lamp bulbs of standard screw type, the cable joints and receptacle being encased in a soft rubber sleeve, the free end of which snaps over and is clamped around the neck of the lamp bulb forming a watertight cover for the terminals.

Lights, diving.

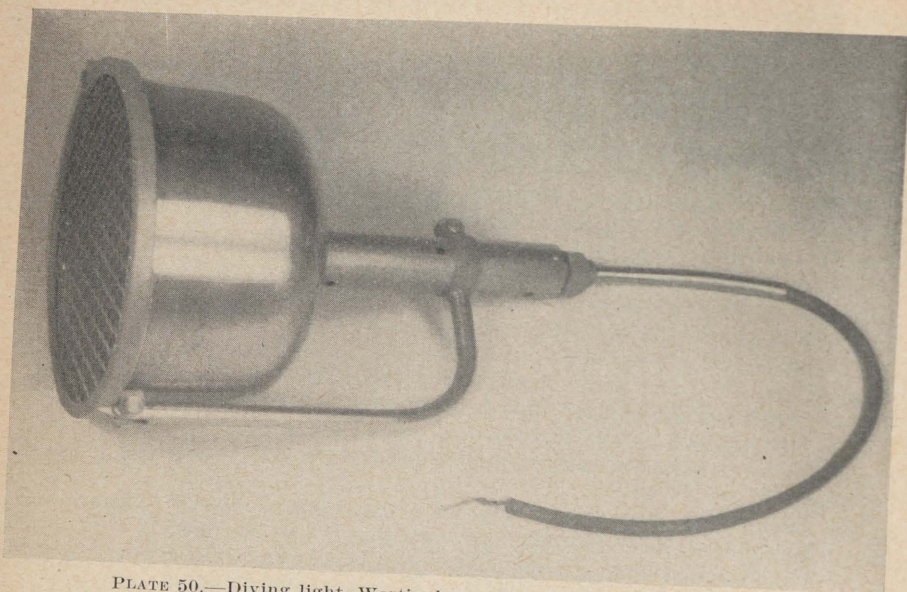

PLATE 50.—Diving light, Westinghouse Lamp Co. type—Assembled.

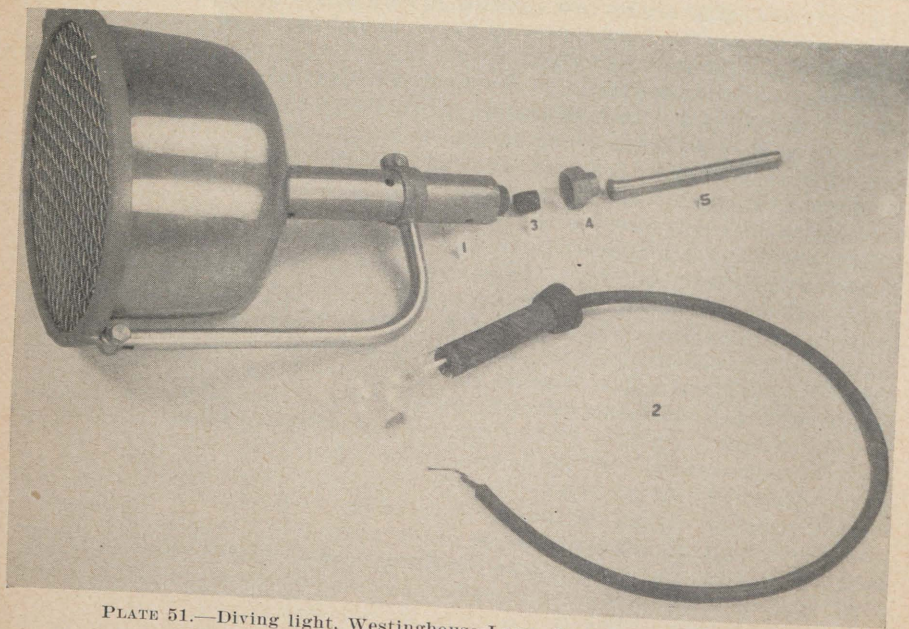

PLATE 51.—Diving light, Westinghouse Lamp Co. type—Disassembled.

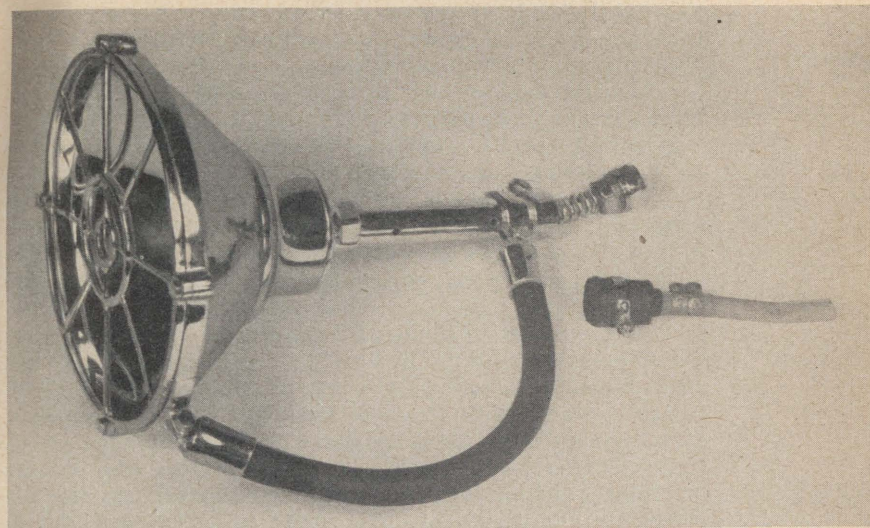

PLATE 52.—Diving light, A. J. Morse & Co. type—Assembled.

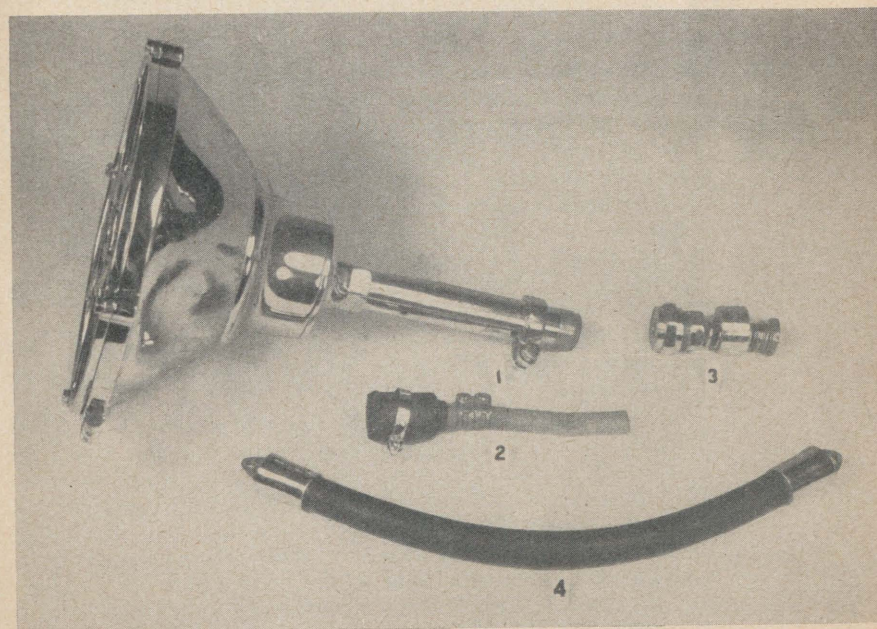

PLATE 53.—Diving light, A. J. Morse & Co. type—Disassembled.

The lamps of diving lights should never be lighted in air as the heat generated burns out the bulb filament in a few seconds. The light should be submerged before lighting and the current should be turned off before the light is hoisted from the water.

Lines.

Lines used in diving and salvage operations are those extending from the surface ship to or in vicinity of the diver. In general, they are as follows:

**Blowing hose.**—Blowing hose is used for blowing and venting air to and from compartments, tanks, etc., under water. The hose usually used for this purpose is the 1¼-inch diameter pneumatic air hose supplied to rescue and salvage vessels. The ½-inch diameter diving hose is also used for this purpose where the operations are not of the magnitude requiring the use of larger size hose.

**Descending lines.**—Descending lines are the medium by which the diver descends to the bottom. In rescue and salvage work, after the sunken vessel has been located, a line is usually attached to the wreck by the diver and taken to the diving vessel. In subsequent dives the diver slides down this descending line in order to reach the desired point on the wreck. For descents in ordinary diving; viz., for searching, observations, etc., the descending line is lowered direct to the bottom by shackling its end into the eye of a 100-pound weight (pl. 75). In strong tide-ways, should the 100-pound weight not remain on the bottom, additional weights must be added.

Standard descending lines are made of 3-inch circumference manila rope. The lines are 200 feet long and are cable laid to prevent twist and to make identification by the diver easy.

**Distance lines.**—Distance lines are made of 15-thread cable-laid manila 60 feet in length. The line is bent onto the descending line just above the descending line weight. It is used by the diver in rotary searching and as a guide for relocating the descending line when he is ready to ascend. Standard distance lines are made up into loose coils for convenience of the diver.

**Hauling lines.**—Hauling lines may be either wire rope up to ¾-inch diameter or manila line up to 1½-inch circumference. Hauling lines are used by surface attendants to assist the diver in lifting or moving heavy objects on the bottom.

**Diving-light cable.**—The diving-light cable is the electric cable carrying the copper conductors for the diving light. This cable is approximately ½ inch in diameter.

**Life line and air hose.**—The life line and air-hose line is that combination of life line or telephone cable and the diving air hose which is lashed together by marline at stated intervals along its entire length and by a canvas sheath at the lower end.

**Lowering lines.**—Lowering lines vary in size from 4-inch manila to 9- or 12-thread material. They are the lines that are attached to objects being sent to the bottom and are also used for the purpose of controlling the movement or position of these objects.

**Reeving lines.**—Reeving lines are the combinations of 1½-, 2½-, 4-, and 6-inch manila, and 1-inch wire rope, which are passed

through the tunnels blown under sunken vessels preparatory to hauling through the pontoon chains. (See ch. XIX.)

**Stage lines.**—Stage lines are made of 3-inch and 4-inch manila and are used to raise and lower the diving decompression stages. As furnished with the small stages they are of 3-inch manila and 112 feet long, with marks 10 feet apart corresponding to decompression stops; the first mark being so located as to be 10 feet from the bottom of the stage platform when shackled to the platform. The upper ends of the lines are whipped to prevent fraying. The lower ends are fitted with thimbles and sister hooks (or shackles) for attaching the lines to the slings of the stage. Two lines are used with the small stage.

The stage line for the larger stages is made of 4-inch manila. As shown by plate 67 only one line is required for each stage. They are made up on board ship in lengths consistent with the depth of the dive.

The stage lines for the smaller stage are marked with metal tags perforated or formed in strips, as illustrated on plate 68, to indicate the depth of submergence of the stage. The lines of the large stage are usually marked with colored rags (flag bunting) to indicate the depth of submergence, as follows:

10 feet, 1 cloth tag (red).	90 feet, 3 cloth tags (blue).
20 feet, 1 cloth tag (yellow).	100 feet, 4 cloth tags (red).
30 feet, 1 cloth tag (blue).	110 feet, 4 cloth tags (yellow).
40 feet, 2 cloth tags (red).	120 feet, 4 cloth tags (blue).
50 feet, 2 cloth tags (yellow).	130 feet, 5 cloth tags (red).
60 feet, 2 cloth tags (blue).	140 feet, 5 cloth tags (yellow).
70 feet, 3 cloth tags (red).	150 feet, 5 cloth tags (blue).
80 feet, 3 cloth tags (yellow).	

Diver's air manifolds (pl. 54) are brass castings. They have one inlet and three outlet nipples, and are suitable for use in connecting the delivery air of three diving pumps to a single diver's air hose or vice versa.

Manifolds,  
diver's, air.

The standard diving air pump, mark III, plates 55 to 60, inclusive, is a twin-cylinder, double-acting, manually operated pump. The complete pump consists of the following principal parts:

Pump, diving,  
air.

**Frame.**—The frame, plate 59, is of rigid design and constructed of cast iron. The manufacturer's serial number of the pump is plainly stamped in visible figures on the upper center of the upper rail-rod support. The frame is strengthened by horizontal braces supporting the crankshaft and bedplate. It is firmly secured to the pump case by four brass holding-down bolts which pass through the foot lugs of the frame and the bottom of the case.

**Bedplate.**—The bedplate is made of gun metal, bolted to the pump frame, and forms a true base and support for the cylinders. Cast integral with the bedplate and located on its under side are two oblong boxes or air reservoirs which are fitted with cover plates bolted in place and made airtight by means of leather gaskets.

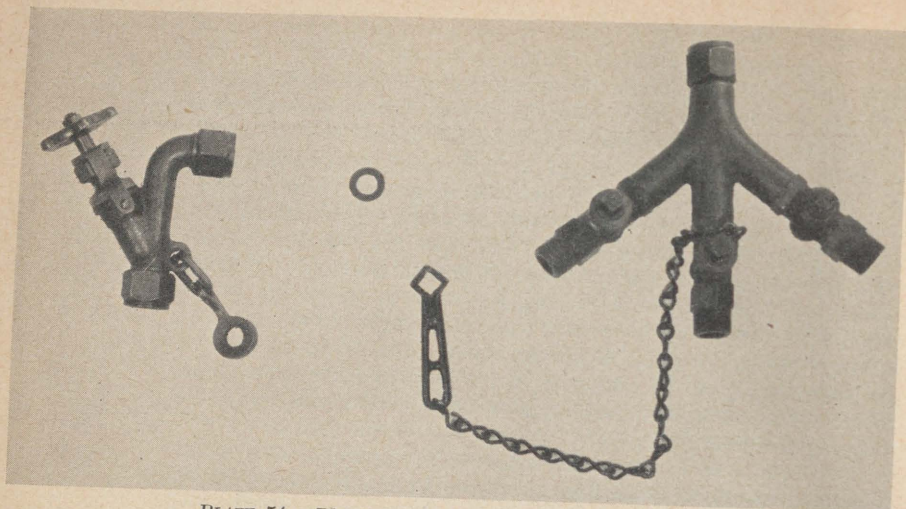

PLATE 54.—Diver's control valve and air manifold.



PLATE 55.—Navy standard diving air pump, Mark III, assembled—  
Front view.

*Cylinders.*—The cylinders have an internal diameter of  $4\frac{1}{4}$  inches, with a stroke of  $7\frac{1}{4}$  inches. Their calculated or theoretical output is 405 cubic inches of free air per revolution. The required efficiency of a new pump when operated against a pressure of 100 pounds per square inch is 80 percent, with a corresponding increase of efficiency at lower pressures. The cylinders, which are made of gun metal, are bolted and sweated permanently to the bedplate. They are located parallel to each other and finished dead smooth inside to exact dimensions.



PLATE 56.—Navy standard diving air pump, Mark III, assembled—  
Back view.

*Cylinder covers.*—The cylinder covers are made of gun metal, are interchangeable, and are bolted to the flanges on the cylinders. They are fitted with inlet and outlet valves, cylinder oil cups, and piston-rod stuffing boxes. The inlet air openings, oil cups, and stuffing-box glands are elevated above the water overflow outlet of the water cistern. The cylinder-cover joints are made airtight by leather gaskets. Air passages are drilled through a rib case on the front of each cylinder, thus connecting the air spaces of the upper outlet valves with the air reservoir on the under side of the bedplate. Each air reservoir receives air from its respective cylinder. The lower outlet valves are located, one each, inside the air reservoirs.

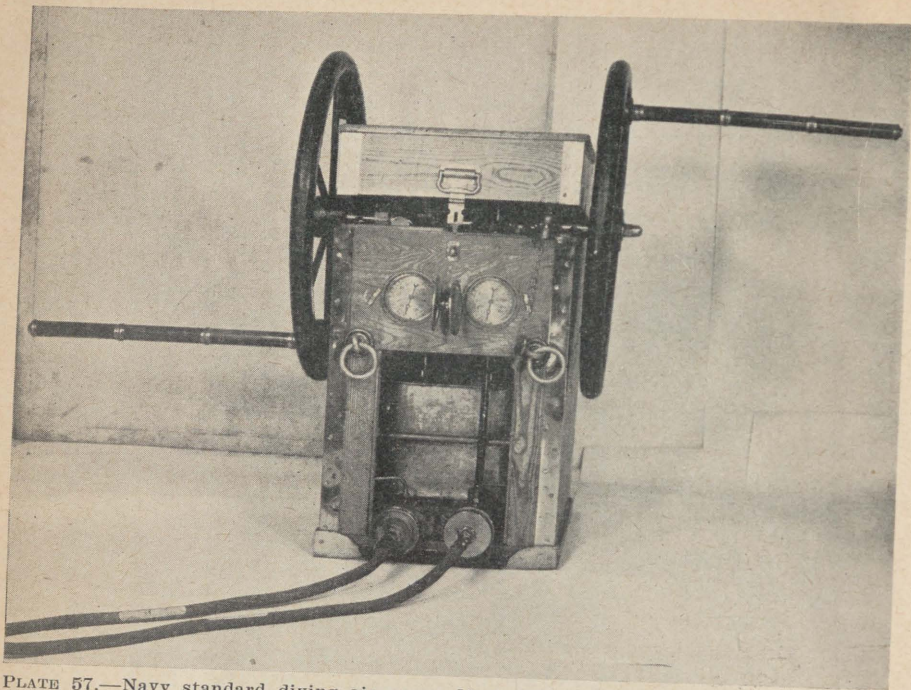

PLATE 57.—Navy standard diving air pump, Mark III, with top raised and front cover removed.

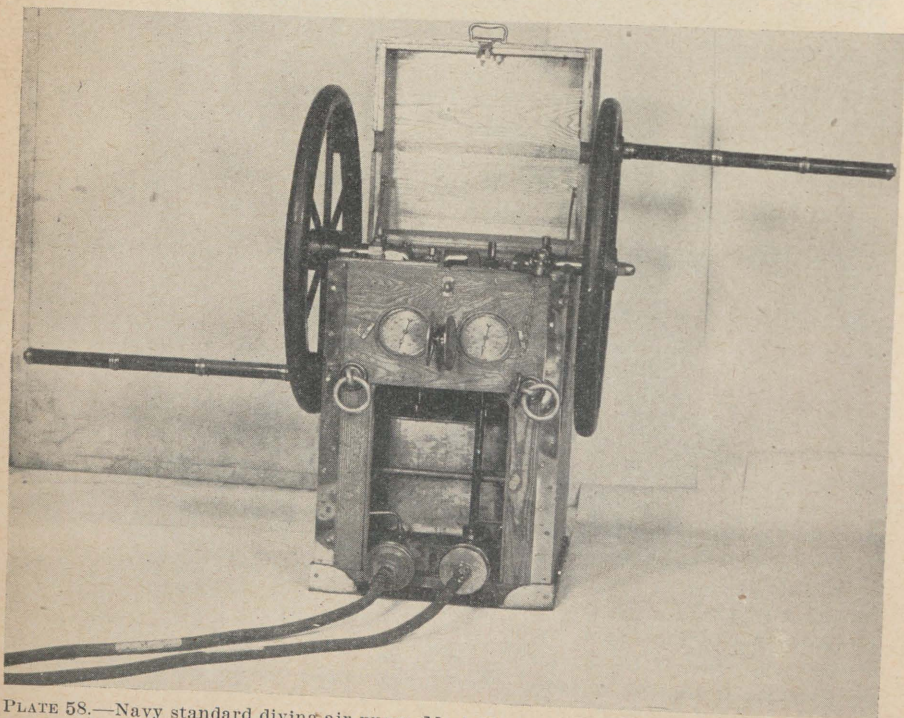

PLATE 58.—Navy standard diving air pump, Mark III, arranged to supply air for two divers.

*Intake and exhaust valves.*—The intake and exhaust valves made of bronze are interchangeable and are faced with leather on either side. The valves are held on their seats by spiral brass springs under light initial tension; the valve stems moving in guides formed in the valve casing of the valve bodies. The valve bodies are each made in two parts; one part of each being permanently secured over a valve opening into a cylinder, thus forming an integral part of the combined cylinders and bedplate. The removable part of the valve body is termed a valve-body cap. This arrangement is simple, efficient, and provides an easy access to the valves.

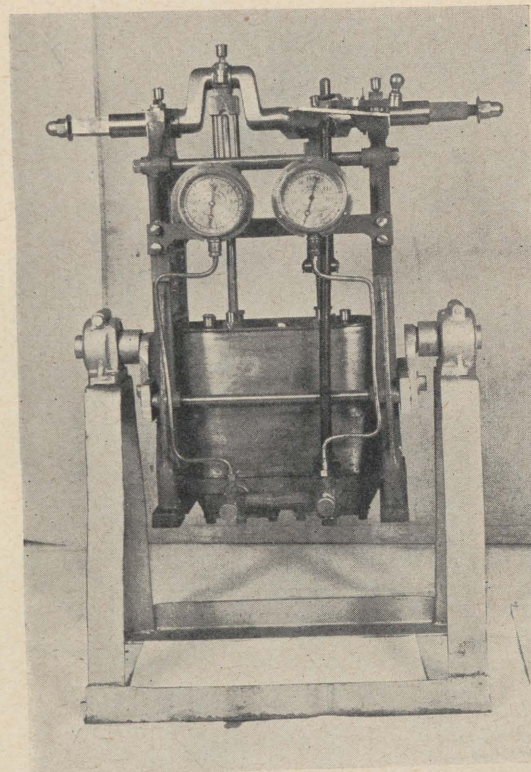

PLATE 59.—Navy standard diving air pump, Mark III, removed from case.

*Air reservoirs.*—The air reservoirs are fitted with air-delivery nozzles, to each of which an oil separator is screwed before using the pump to furnish air to divers. The diver's air hose is coupled to the male submarine threaded portion of the oil separator (pls. 63 and 64). The delivery nozzles are cross-connected, and a two-way transfer valve with valve rod and shifting handle is fitted in the cross connection and is so arranged that the air from each cylinder may be directed out its respective delivery nozzle or the air from both cylinders may be directed out the left delivery nozzle. Hence, with the pump being operated at

ordinary speed, air may be supplied to two divers working in moderately deep water (60 to 80 feet).

*Transfer valve.*—The transfer valve is of the plug-cock type with a T-opening. The valve stem is made short and square in sections. A long valve connecting rod is fitted at its upper end with a valve-operating handle and at the lower end with a square female socket that slips over the short valve stem. The transfer valve and its connecting rod are housed inside the pump case; the valve-operating lever being located to the front and at the pump case cover joint at which point a direction plate is located that indicates the position of the valve ports.

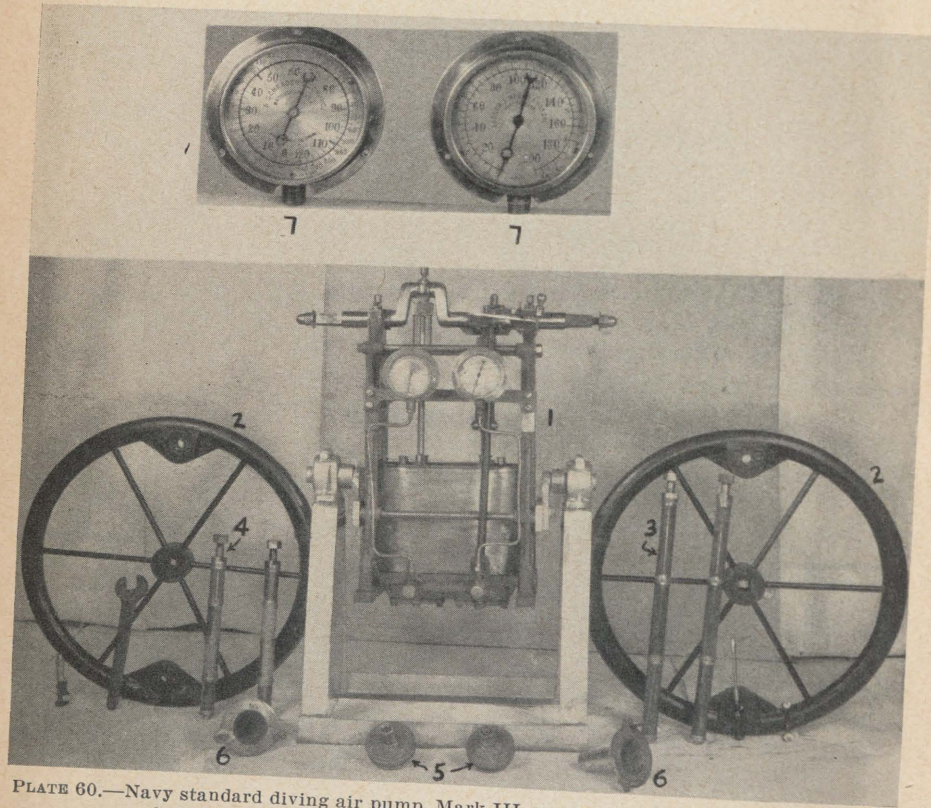
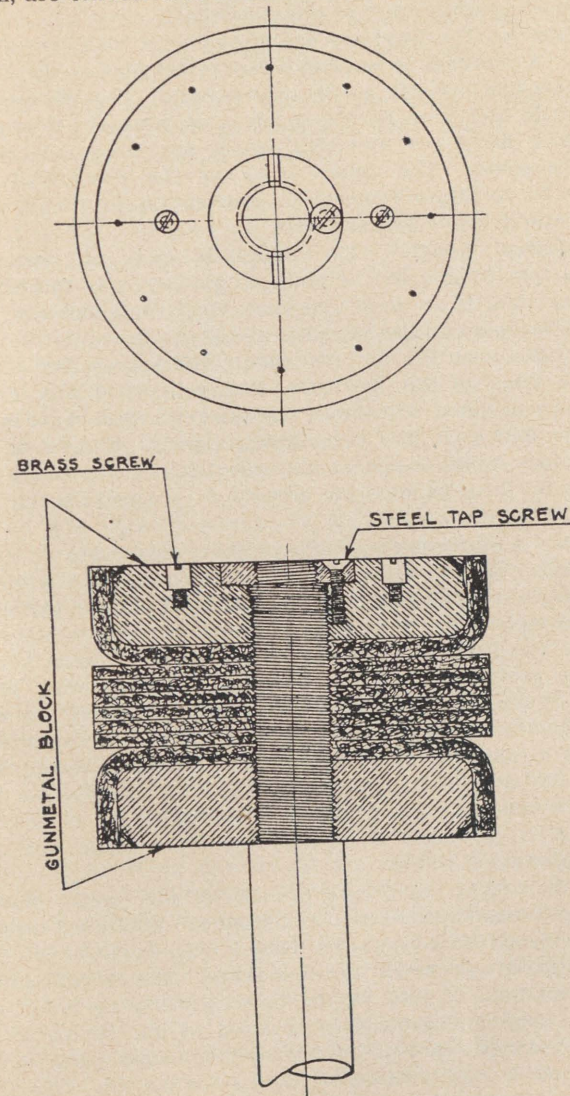

PLATE 60.—Navy standard diving air pump, Mark III, removed from case and showing pump wheels, handles, oil separators, and enlarged view of pump gages.

*Pistons.*—The pistons (pl. 61) are composed of inverted cup leathers and leather disks held together by metal blocks screwed left-handedly onto the respective piston rods, and are prevented from backing off by lock nuts and set screws. In operation, the air holes (see illustration) admit air to the grooves cut around the periphery of each block; thus when the pressure is developed, the air forces the leathers against the walls of the cylinders and prevents leakage of air past the pistons. The piston clearances are adjusted as close as possible, so that on each stroke prac-

tically all the air that is compressed by the cylinders is forced out.

*Piston rods.*—The piston rods pass through the cylinder-cover stuffing boxes and the piston-rod guides located in separate guide supports fastened to the angle braces of the pump frame. Connecting slings are pivoted to the square sections on the rods which, in turn, are connected to brass bearing blocks on the crankshaft.



PISTON FOR  
TWO-CYLINDER DOUBLE-ACTING DIVING AIR PUMP.  
MARK III

PLATE 61.—Navy standard diving pump piston.

*Crankshaft.*—The crankshaft of forged steel revolves in the journal bearings on the pump frame. The cranks are set at approximately 90° from each other and the ends of the shaft project from the pump case on either side sufficiently to provide room for the flywheels. The ends of the shaft are threaded and fitted with turned brass nuts for holding the flywheels in place. Brass oil drip cups packed with wisps of hair felt are fitted to each upper bearing brass of the crankshaft.

*Flywheels.*—The flywheels are of cast iron with wrought-iron spokes. A provision is made to secure either long or short pump-wheel handles directly to the wheel rims. The wheels weigh 150 pounds each, and have a square hole machined through the hub which fits a corresponding square section on the ends of the crankshaft. The square ends of the crankshaft taper slightly to facilitate removal or application of the flywheels. The flywheels are interchangeable.

*Pump-wheel handles.*—The improved type of pump-wheel handles (pls. 57 and 60) of multiple quill type is furnished in two sizes: No. 1, or large size, and No. 2, or small size. The large size accommodates six men at the pump, while the small size provides room for only four men. The handles bolt directly into the rims of the flywheels, and consist of lignum-vitae quills each mounted with brass ferrules on a steel shaft in such a manner that each quill turns independently. The set of short handles are stored inside and at the back of the pump case, whereas the long handles are secured in brackets in the front corners of the case.

*Cistern.*—A water cistern made of sheet copper heavily tinned inside and outside surrounds the pump cylinders, and is secured to the bedplate. The cistern is of sufficient height to permit the contained cooling water to flood the top and sides of the cylinders. At the back of the pump case, necessary water connections are provided for filling, draining, or overflowing of the cistern. When the pump is used in warm weather, the water cistern must be filled with cold water and the water changed as often as it warms; otherwise, the air furnished the diver or divers will be heated to such an extent as to endanger their physical well-being. An overflow nozzle similar to a male hose connection is furnished to lead clear of the pump any overflow of the cooling water.

*Pump case.*—The pump case is made of high-grade, well-seasoned, fine-grained white ash. The sides are dovetailed together at the corners, the corners are bound with angle brass. The bottom edges are protected by brass shoes. The cover is hinged at the back and is held in the open position by cover supports. A large removable door is fitted in an opening at the front of the case through which opening some parts of the pump are more readily accessible than from the top. The pump gages (pls. 58 and 60) are located on the inside of the case with their dials visible through circular openings cut in the front of the case. These dials are protected by brass covers hinged on the outside and front of the pump case. When not in use, the

ends of the crankshaft are protected by caps bolted to the pump case. These protecting caps should never be used for lifting the pump case. Wrought-iron lifting rings are secured on front and back of the case for such purposes. Their bolts pass through the wooden frame and are fastened into a stiffening iron that encircles the inside of the case. The opening at the bottom of the case is closed by a brass cover held in place by a number of wing nuts. The plate is dished so that the dripping oil or water will be drained towards the center, where a drain plug is located.

In the upper part of the case at the back, a wooden till is provided for the following tools and spare pump parts, which should be kept on hand at all times:

- 2 gaskets, cylinder-head.
- 1 nozzle, overflow.
- 1 nut, pump handle, spare.
- 1 nut, pump wheel, spare.
- 1 pound packing, piston rod.
- 1 box containing spare leathers in oil for one piston.
- 1 tool, assembling, piston.
- 1 tool, lock nut, piston.
- 2 valves, pump, complete, spare.
- 4 washers, pump, valve body.
- 1 wrench, double open end, for crankshaft bearing bolt and nuts.
- 1 wrench, double open end, for crankshaft and cylinder oil cups, and helmet transmitter securing nuts.
- 1 wrench, open end, for nuts on pump air manifold.
- 1 wrench, socket-type, for cylinder head bolts.
- 1 wrench, spanner, face, piston.
- 1 wrench, spanner, pump.

*Piston assembling tool.*—The assembling tool (pl. 62) for use in installing the pistons into the cylinders of the diving pump is made of gun metal, in two parts hinged together, and is fitted with a clamping screw and wing nut. New pistons, when assembled, fit the cylinders very neatly, thus making the use of this tool necessary to avoid injury to the edges of the lower cup leathers. When the pistons are difficult to insert, pressure must be applied; therefore, it is necessary to provide a length of pipe to fit over the piston rod, upon which pressure may be applied without injury to the piston rod. This pipe is of a temporary nature and should be longer than the piston rod with its lower end resting upon the metal part of the piston.

The oil separators (pls. 63 and 64) are furnished to prevent oil that the air may carry over from the pumping system from being blown into the air hose. Each separator is made of two bronze cups screwed together against a leather gasket. The air current within the separator is directed by a baffle through a lufur sponge, sewed with fine copper wire, which filters the air before entrance into the air hose.

Separators.  
oil.

## Shoes, diving.

The weighted diving shoes adopted as standard by the Navy are shown on plate 65. The shoes are furnished in pairs. Each shoe weighs approximately twenty pounds and is of the following dimensions:

Length inside, approximately 13 inches.

Height inside of heel, approximately  $6\frac{5}{32}$  inches.

Height inside,  $\frac{1}{2}$  inch from inside surface of toe,  $1\frac{3}{4}$  inches.

Height inside, 5 inches from inside surface of toe,  $2\frac{1}{4}$  inches.

Height inside,  $4\frac{1}{2}$  inches from inside surface of toe,  $2\frac{1}{4}$  inches.

Each shoe consists of a lead sole, a hardwood upper sole and leather uppers. The lead sole is a one-piece casting  $\frac{5}{8}$  inch thick and  $14\frac{1}{8}$  inches long, containing six drilled holes  $\frac{21}{64}$  inch in diameter, counterbored for the  $\frac{7}{8}$ -inch diameter by  $\frac{1}{8}$ -inch thick rivet heads and washers which secure the upper sole to the lead sole. The upper sole is made of  $1\frac{1}{4}$ -inch thick maple, free from knots, worm holes, cracks, etc., rabbeted around its upper peripheral edge with a rabbet  $\frac{1}{2}$  inch deep by  $\frac{3}{8}$  inch wide. The upper sole is drilled and counterbored with six rivet holes to coincide with the rivet holes in the lead sole. The upper sole is riveted to the lead sole by six Tobin bronze cold-drawn rivets, the top of the head of the rivets being flush with the top surface of the inner sole. The ends of the rivets termi-

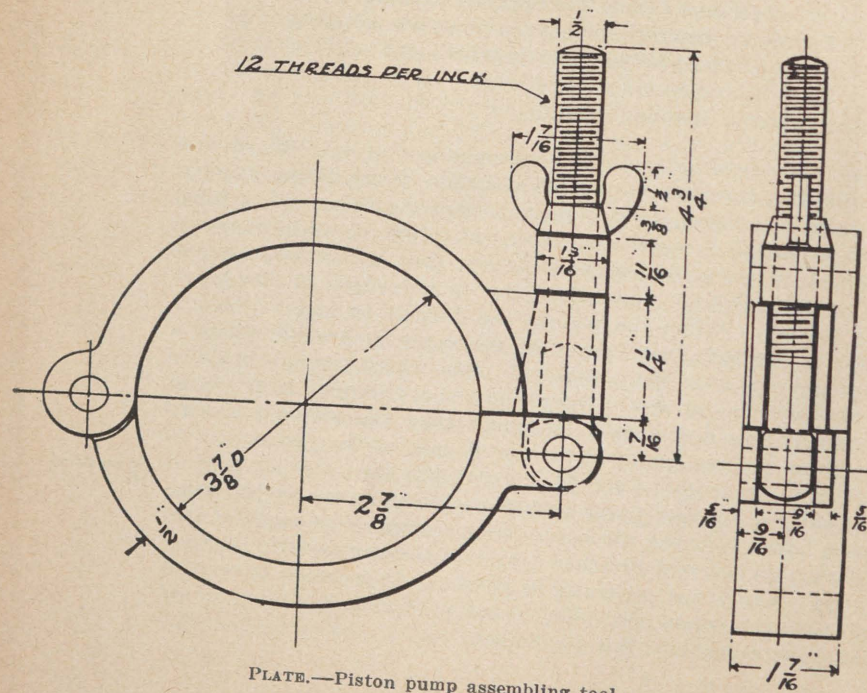

PLATE.—Piston pump assembling tool.

nate in the counterbore of the lead sole and are each fitted with bronze washer and then smoothly peened over the washer by spinning. The wooden soles before assembly are made waterproof by boiling for a period of 3 hours in paraffin.

The leather uppers are made of the best quality steer hide, fully tanned by the mineral-tan process free from acid, alkalis, or make weights other than the filler necessary to make the leather waterproof. The outside surface is black. The leather, before acceptance, is required to have a tensile strength, before splitting, of not less than 4,000 pounds per square inch; the elongation in a length of 2 inches not to exceed 30 percent and withstand immersion in a neutral solution of 20 percent water and 80 percent glycerine at a temperature of  $275^{\circ}$  F. for 1 hour without deterioration.

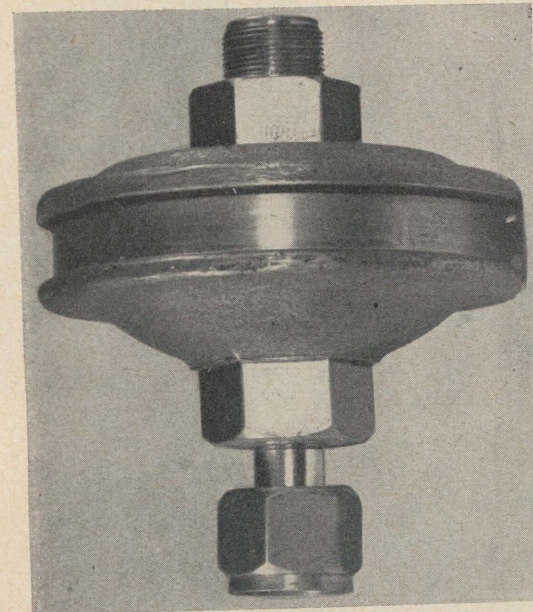

PLATE 63.—Oil separator—Assembled.

The uppers are provided with leather tongues and three  $\frac{5}{8}$ -inch wide leather cross straps on one side and three  $1\frac{1}{16}$ -inch brass buckles of the center-pin type on the other. The leather parts are stitched together with five stitches per inch of suitably waxed Nos. 6 and 7 black thread with triple seam about  $\frac{3}{8}$  inch apart. In addition to sewing, buckle straps and cross straps are each riveted with two  $\frac{3}{16}$ -inch diameter tubular brass rivets. Three tubular brass rivets are also used in the tongue strap and pull strap. The uppers are attached to the rabbet edge section of the upper sole by means of copper nails and a copper binding strip. The leather is nailed to the sole with one row of 29 copper nails  $\frac{3}{4}$  inch long,  $\frac{5}{32}$ -inch diameter flat-head, 15 gage-through copper washers of approximately  $\frac{1}{4}$ -inch overall diameter, spaced equally around the shoe. The copper strip is

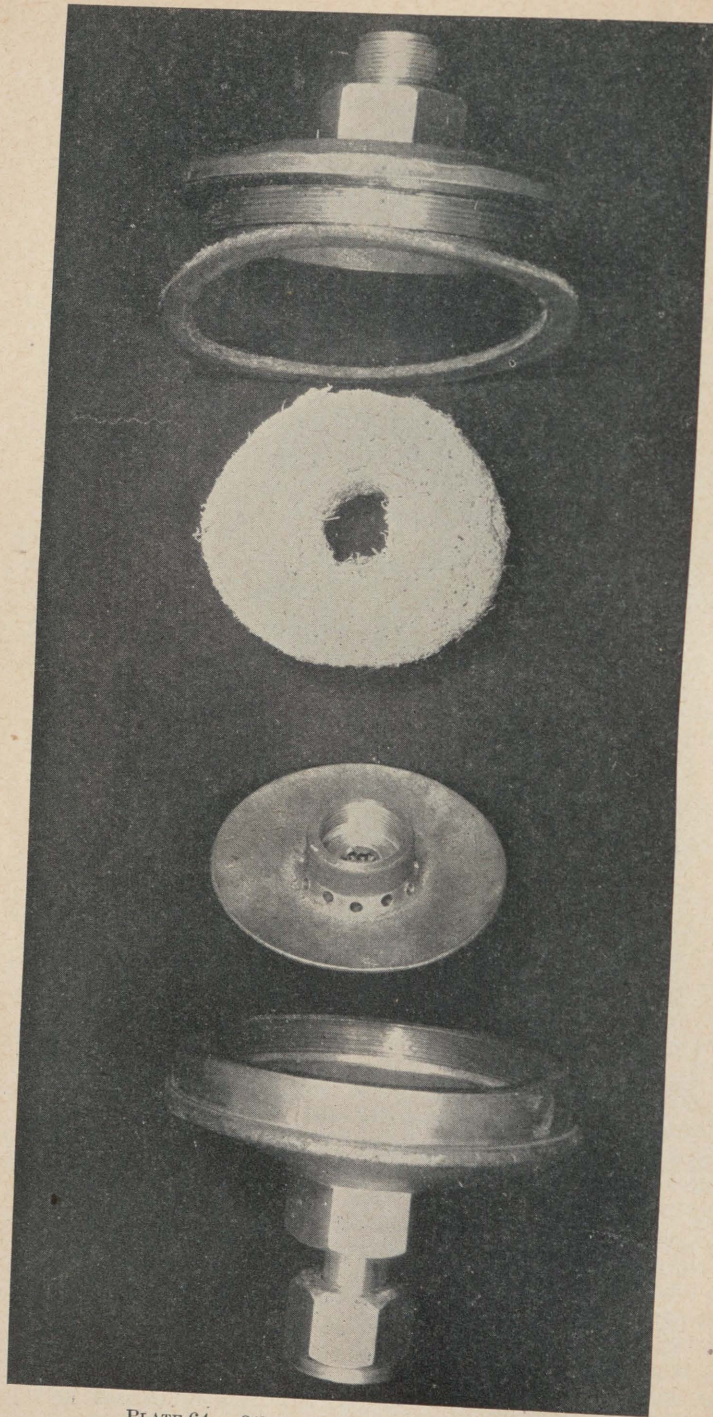

PLATE 64.—Oil Separator—Disassembled.

then nailed over the leather with 31 copper  $\frac{1}{4}$ -inch diameter flat-head, 13-gage copper nails equally spaced between the spaces of the under row of nails. The nail holes in the wooden sole and copper strip are drilled with a No. 50 drill before driving in the nails. The copper bending strip is of soft copper  $\frac{1}{2}$  inch wide No. 20 B. & S. gage. The upper edge of the copper strip is rounded and, as installed, the ends butt at the toe end of the shoe.

The toe of the shoe is protected by a toeplate, cast of bronze and polished. The plate is  $\frac{5}{32}$  inch thick and is shaped to fit the toe end of the upper sole and to allow a clearance of  $\frac{3}{16}$  inch above the leather toe of the shoe. The bottom edge of the toe plate is flush with the front end of the lead sole. It is attached to the wood sole by means of five flat-head 1-inch No.

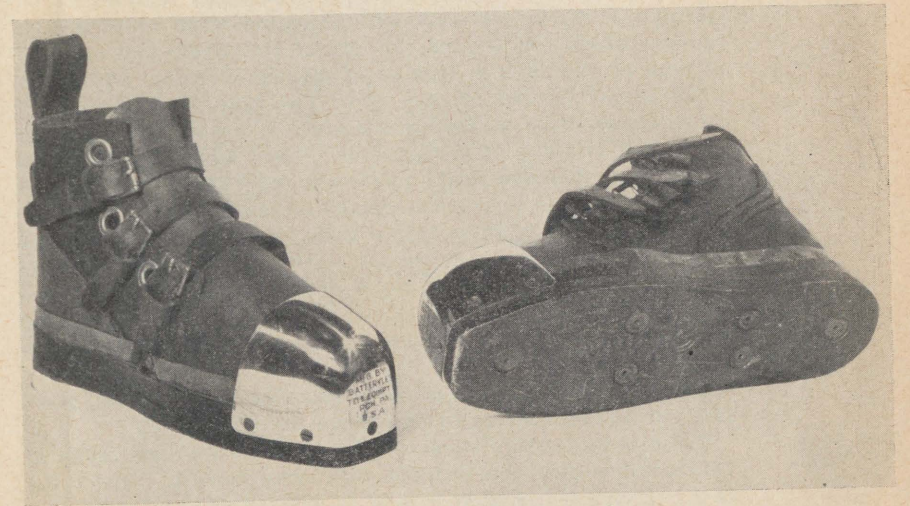

PLATE 65.—Navy standard diving shoes.

10 brass screws. A new type shoe, similar to the leather shoes as far as the dimensions but made of canvas, is being adapted for Navy use. This shoe has a square toe and is constructed so that any of the component parts, lead sole, wood sole or canvas upper, may be replaced.

The grommets or eyelets are of brass, standard No. 3, of the outer- and inner-ring type, with inside diameter  $\frac{1}{2}$  inch.

The diving decompression stages are shown on plates 66, 67, and 68. They are furnished in two sizes; a large size (48 by 60 inches) and a small size (18 by 36 inches). Both stages are identical in construction and vary only in size. The platforms of both size stages are made of 10.2-pound steel plate perforated with  $\frac{1}{2}$ -inch diameter holes 1 inch between centers. On the small stage the edges of the platform plating are bent down at a 90° angle along its length to provide greater lateral support and an open base for the platform. On the large stage the platform is welded to 3- by 2- by  $\frac{1}{4}$ -inch angles for the same purpose. Six galvanized eye bolts of approximately  $\frac{1}{2}$ -inch di-

Stages,  
decompression.

anometer wire and 1½-inch inside diameter eye are secured to the platform, one at each corner and one in the middle of each end by riveting. The corner eye bolts are for connecting the legs of the bails. The center eyebolts in the ends of the stage are for attaching guy ropes for steadying the stage and for suspending weights to the stage.

The stage bails are made of round galvanized-iron rod bent into the shape of an inverted V with a rounded apex. The lower ends of the two bails terminate in eyes which pass through the eyes of the corner bolts on the stage. This construction permits the bails to swing down flat against the stage in stowage.

The small stage is lowered to desired depths by 3-inch manila lines, each 115 feet long, as shown on plate 66.

The large stage (pls. 67 and 68) is usually lowered by one 4-inch manila line, a bridle, and an interposed spreader. The spreader is 42 inches wide with elongated eyes at each end, through which are secured the legs of the bridle and one end of each of two 30-inch lengths of 5/8-inch diameter wire rope, thimble and served at each end. The other end of each of these two sections of rope is shackled to the eye of the stage bail. The bridle is of one piece of 5/8-inch diameter wire, with a bight seized in the center to form an eye. The length of the wire is such as to form a triangle 36 inches in height.

The platforms of these stages some years ago were made of galvanized flat iron bars spaced about 1 inch apart. It was found that it was possible for a diver to come up under the stage and foul some of the helmet fittings between the bars of the stage. The perforated plate was accordingly adopted as the standard platform.

A detailed description of the decompression stage lowering lines is given in this chapter under "Stage lines."

The diver's dressing stool (pl. 69) is 19 inches high, made of 1-inch yellow pine, and painted with clear varnish. Under the 14- by 18-inch seat a shelf is built in which should be stored the wing nut T wrenches, wing nuts, copper washers, breastplate segments, a pair of pliers, and a 1 3/8-inch open-end wrench.

Testing tanks (pl. 74-A) are made of steel, are of 1 cubic foot capacity, and are fitted with a gage registering 300 pounds, pet cock, inlet and outlet nipples which are submarine threaded to take the diving air hose, transportation handles, and a name plate marked with the capacity, date, and place of manufacture, and the test pressure to which the tank has been subjected. The tanks are required to withstand an internal test pressure of 600 pounds per square inch before its acceptance from manufacturer. It is used for proving the efficiency of diving air pumps and as an expansion tank or low-pressure receiver when diving with compressed air supplied from air flasks or air-flask banks such as used in some diving launches.

Communication between submerged divers, and their surface tenders may be accomplished by (1) telephonic transmission, (2) mechanical transmission of hand signals by pulls on the life line, and (3) messages written on slates or the equivalent, lowered and hoisted to and fro from deck to diver.

Stool, diver's,  
dressing.

Tanks.

Telephones,  
diving.

GENERAL NOTES

1. ALL METAL PARTS TO BE GALVANIZED.
2. LEATHER TAGS ON EACH ROPE TO BE MADE AND ATTACHED AS FOLLOWS

LEATHER TAGS ON EACH ROPE TO BE MADE AND ATTACHED AS FOLLOWS	ATTACHED AS FOLLOWS
10 FT. ABOVE STAGE - SINGLE STRAP WITH 3 PERFORATIONS	
20 FT. " " " " " " " " " " " "	2 "
30 FT. & 90 FT. " " " " " " " " " " " "	CUT INTO 3 STRIPS
40 FT. & 100 FT. " " " " " " " " " " " "	2 "
50 FT. & 110 FT. " " " " " " " " " " " "	PLAIN
60 FT. " " " " " " " " " " " "	" RED CLOTH
70 FT. " " " " " " " " " " " "	SINGLE STRAP WITH 2 PERFORATIONS
80 FT. " " " " " " " " " " " "	" " " " " "

LEATHER TAGS 5 1/2" LG. TO BE SECURELY FASTENED BETWEEN & AROUND STRANDS AT EVERY 10 FT. DISTANCE WITH A RED CLOTH TAG AT THE 60 FT. MARKS. STRAPS & TAG TO EXTEND 2 1/2" BEYOND ROPE.

DEVELOPED FROM AND SUPERSEDES C. & R. 206160, BU. NO. 505968 & 505979.

DRAWN BY: P. B. - CHM. *MB*  
 EXAMINED BY: *R. B. Dwyer* PRINCIPAL ENGINEER  
 IN CHARGE OF WORK *R. B. Dwyer* DATE: 8/8/42

**STANDARD PLAN**  
**DIVING APPARATUS**  
 DECOMPRESSION STAGE  
 AND LINES

SCALE 3", 6", & 12" = 1 FOOT

NAVY DEPARTMENT  
 BUREAU OF SHIPS  
 WASHINGTON, D. C.      SEPT. 1, 1942

50 **BU. N<sup>o</sup> 526249** *R. B. Dwyer*  
 FOR CHIEF OF BUREAU



Stool, d  
dressin

Tanks.

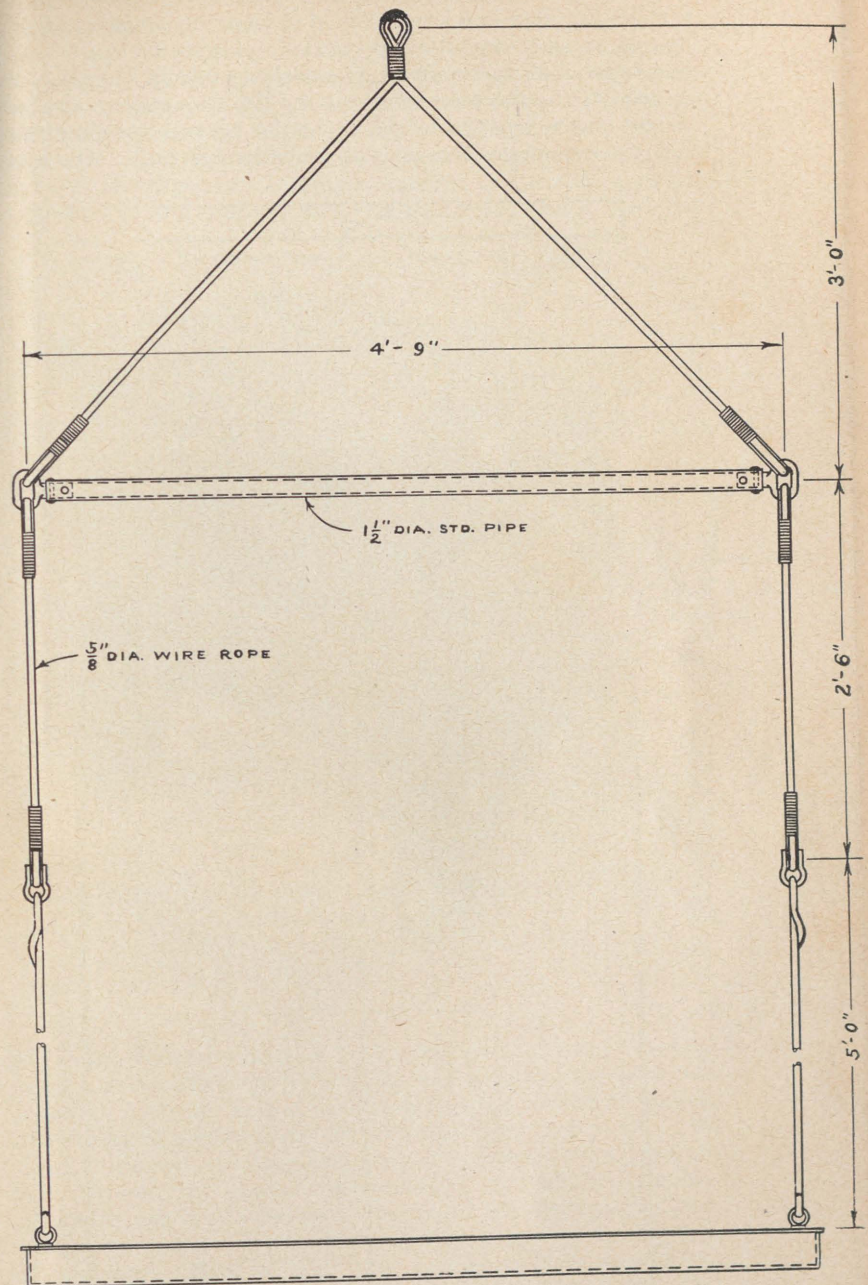
Teleph  
diving.

48" x 60" DECOMPRESSION STAGE WITH SUPPORTS

PLATE 67.—Decompression stage, large, front view.

The practicability of hand signaling obviously is dependent on a clear life line and even then the scope of communication is limited to such single words or short phrases as can be easily memorized and represented by numerical pulls on the line. Also in deep diving the long length of the life line and its attendant weight makes dependable communication by this method difficult. Written communication requires considerable time. The lower-

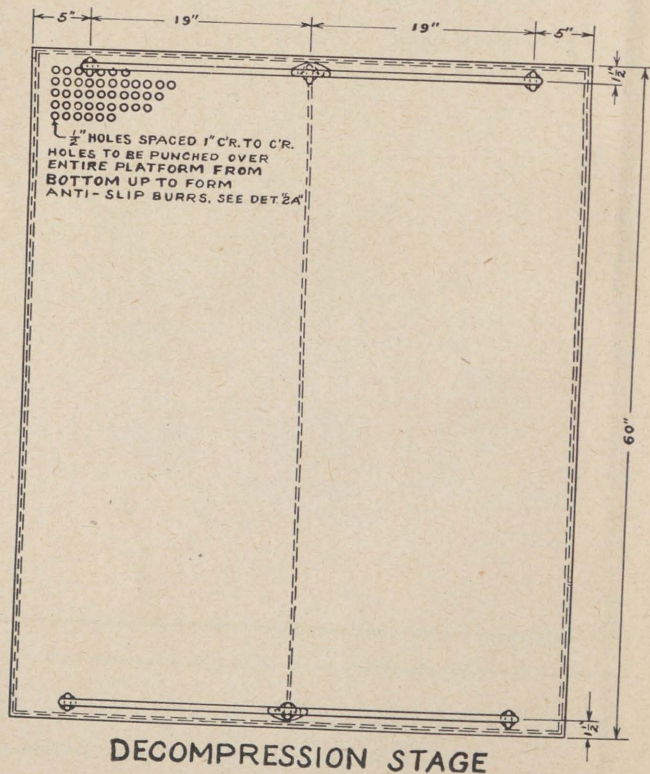
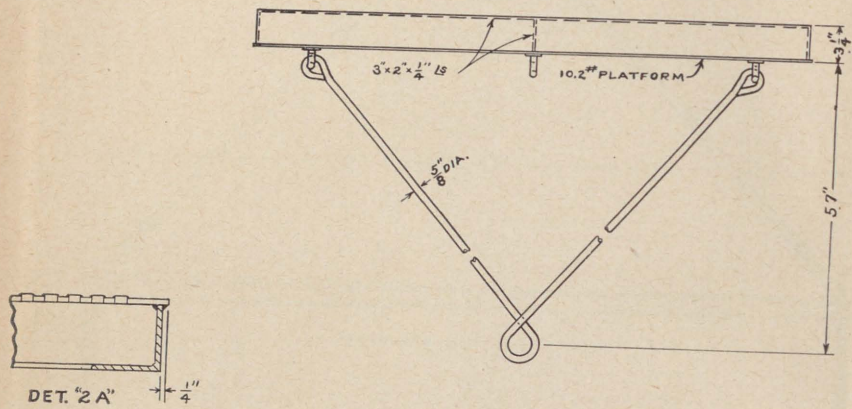

DECOMPRESSION STAGE

PLATE 68.—Decompression stage, large, plan view.

ing lines are susceptible to fouling and the diver is handicapped in writing and distinguishing such messages by restricted visibility. Accordingly, while either of these two procedures may be resorted to in an emergency, the diving telephone or diving amplifier equipment is mainly depended upon for vocal communication with the diver.

Perfection of diving telephones and underwater communication has been the subject of continuous research and experimentation by the Bureau of Construction and Repair from 1912 to 1940 and



PLATE 69.—Diver's stool.

by the Bureau of Ships from 1940 to the present time. Dry-cell battery, storage battery, batteryless, and amplifier types of telephones in the order named have been tested and used in service. After years of service tests, the consensus was that of all of the types mentioned, the amplifier type of communication gave the most satisfactory results. Accordingly, the diving amplifier equipment has been adopted as the Navy standard diving communication equipment and stocks are being filled with this type of equipment. Issue of all diving telephones has been discontinued and all equipment being issued at the present time is of the diving amplifier type. However, as some of the telephones are still in service and will be continued to be used until no longer serviceable, the following descriptions of each type are desirable for identification and information.

Telephone.  
dry-cell type.

The dry-cell battery type of telephone is shown on plate 72. It consists of the battery box, the diver's head set, the diver's transmitter, the attendant's outfit, and the telephone cable and couplings.

**Battery box.**—The battery box contains the battery of 12 dry cells which are connected to the terminals of an on-off switch. Couplings are provided on the box for the diver's and the attendant's telephone cables.

**Diver's head set.**—The diver's head set consists of an adjustable canvas cap to which the telephone receivers are attached. The cap fits firmly on the diver's head and the rubber ear pieces of the receivers are held snugly against the diver's ears by the tension exerted by a chin strap. The receivers are connected in parallel by a telephone cord. The free end of this cord is fitted with a plug that connects into a receptacle located permanently inside the helmet.

**Diver's transmitter.**—The diver's transmitter is located in a recessed box on the inside of the helmet, to the left and slightly above the faceplate.

**Diver's attendant's outfit.**—The attendant's outfit consists of a single receiver fitted to a spring head band, a transmitter, a telephone cord, and a coupling that is attached to an outlet on the battery box. When not in use, the attendant's outfit and the diver's head set are stowed in the vacant compartment of the battery box.

**Telephone cable.**—The telephone cable originally forming a part of the battery-type telephone system is a combined telephone cable and life line, consisting of three conductors which form the heart of the cable and provide electrical connection from the tender to the diver. The outer woven cover of the cable serves as a life line and as a protection for the conductors. The entire arrangement is a combination of two simple telephone circuits, with one transmitter and one or more receivers in each circuit. Although the two circuits have separate batteries, they have only a single common return. Cables of this type, which are shown on plate 72, when new have a breaking strength of only about 350 pounds. They are no longer carried in stock although there are still some in service. When cables of this type are no longer serviceable, replacement is being made with the rubber-covered cables, plate 14, identical to those used with the diving amplifier equipment, except that they are fitted with adapters designed to fit the terminals on the battery box.

The batteryless diving telephone which is no longer supplied is shown on plates 70 and 70-A. It consists of the diver's outfit, the tender's outfit, the telephone cable, a fiber carrying case, and a control box. This apparatus—as its name implies—does not require batteries nor any other external power supply.

The diver's outfit consists of two receiver units mounted in a snug-fitting leather cap and a transmitter unit mounted in the helmet and equipped with a speaking tube and mouthpiece. The diver's receiver and transmitter units are connected in parallel across two conductors of the telephone cable.

The tender's outfit consists of two receiver units mounted in a head set and a transmitter unit mounted on a breastplate. The

Telephones,  
batteryless  
type.

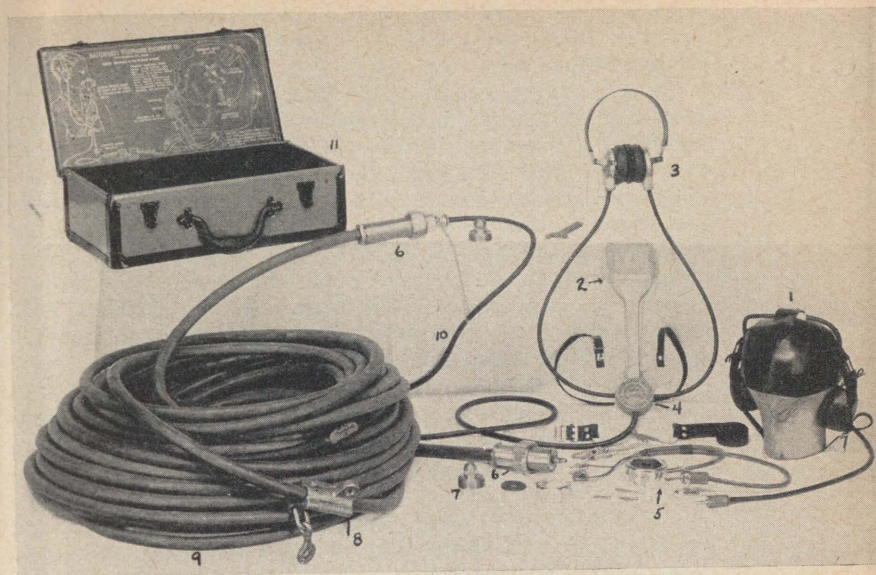

PLATE 70.—Diving telephone, batteryless type.

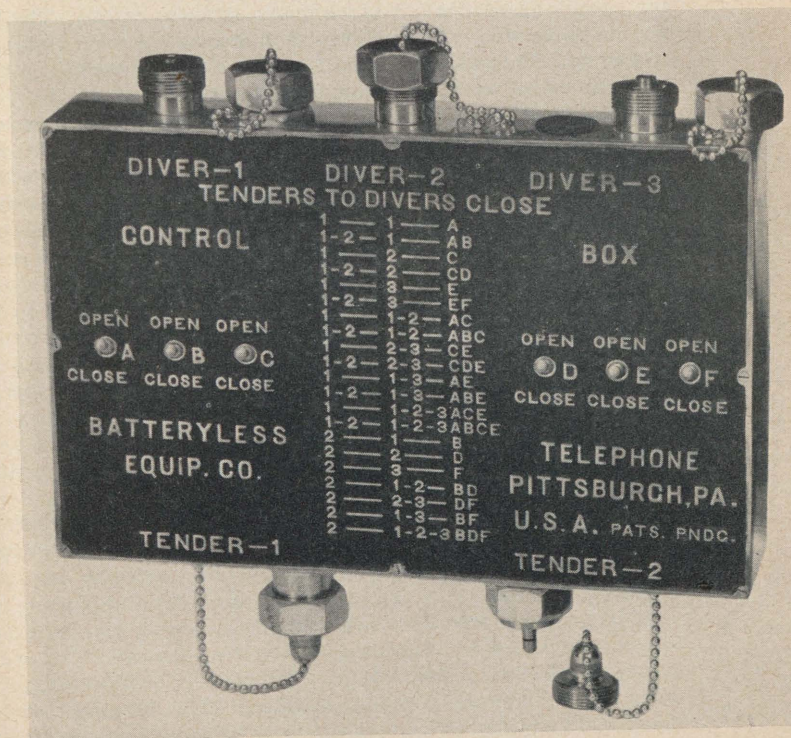

PLATE 70-A.—Diving telephone, batteryless type—Control box.

tender's receiver and transmitter units are connected in parallel across the same two conductors of the telephone cable, leaving two spare conductors.

The six batteryless units, which comprise the two stations, are of permanent magnet, noncorrosive steel, diaphragm-type construction and require no power for the transmission and reproduction of speech other than the voltage generated in the coil by the magnetic impulses set up by the vibrations of a diaphragm relative to the permanent magnets. All of the units are identical and any unit will function as either a receiver or a transmitter without change in connections. Thus, the system may still operate with two inoperative units at each end of the line. Communication may be maintained by using the remaining unit at each end as both transmitter and receiver.

The combination telephone and life-line cable originally furnished with the batteryless telephone system was a rubber-covered cable, with six or seven insulated copper-wire conductors spirally wound around a central phosphor-bronze wire cable. The finished cable had a breaking strength of 5,000 pounds. The weight of this type of cable proved excessive for deep dives and was later superseded by the lightweight cable shown on plate 14 which is standard for use with the various types of telephones and the diving amplifier equipment described herein.

Submarine rescue and salvage operations sometimes require the simultaneous descent of as many as three divers. The batteryless telephone systems furnished salvage vessels include a special control box which contains plugs and switches that permit communication with a maximum of three divers.

The volume of sound produced by batteryless telephone systems is usually insufficient for clear reception by the diver in deep dives due to the hiss of the air supply in the helmet. Thus, it is often necessary to stop the air supply during conversation. An amplifier designed to increase the volume of sound was provided submarine rescue vessels. While the reception was somewhat improved by use of this supplemental equipment, the system still has several objectionable features not common to the amplifier type of diving telephone or the present diving amplifier. Major objections are that the diver's head set which, though soft, is close fitting, uncomfortable, and susceptible to accidental disarrangement.

The amplifier type of diving telephone was the first successful departure from straight telephone communication for diving operations. The equipment is very similar to the present diving amplifier equipment and its component parts are the amplifier with a built-in transmitter-reproducer, the diver's transmitter-receiver, the power cables and the combination diving amplifier and life-line cable.

*Amplifier.*—The amplifier was supplied in two types, according to the power supply. Type A operates from 6 volts D. C. or by means of a series resistor from a 110-volt D. C. line. Type B operates only from a 110-volt D. C. Line. Plate 71, part 1, shows the type B amplifier which is identical to the type A except for the difference in power supplies.

Amplifier-type,  
diving  
telephone.

The amplifier is of a low-gain type designed for communication between the tender and three divers and is arranged so that divers may talk to each other. A portable metal case serves to house the amplifier, the tender's transmitter-receiver, the control panel, and the receptacles. Receptacles are provided for three diving cables, one or two power cables, and a 25-foot cable for a portable transmitter-receiver unit for use on the tender. All receptacles are provided with a cover for protection when not in use. Three talk keys for selecting divers are mounted on the control panel with the power switch. This system retains its relation to the telephone system in that when the transmitter-receiver units are interconnected, they will operate as a batteryless telephone system.

*Helmet transmitter-receiver.*—A transmitter-receiver unit is provided for the diver. This unit has a flexible voice tube which is necessary to provide sufficient volume of sound for successful communication.

*Cables.*—The power cable used in this system is shown as part 16, plate 71. The diving cable is described below under "standard diving cable."

The equipment now being issued for use as the means of communication between a diver and his tender is known as diving amplifier equipment. This equipment is the result of the development of the telephone equipment previously described. It consists of the diving amplifier, the diver's transmitter-reproducer unit, the power cables, and the combination diving amplifier and life-line cable. This equipment is a complete departure from the telephone type of system and contains the advantages of recent developments in amplified speech communication. The main differences in this present system and its immediate predecessor are the use of a relatively high powered amplifier, controlled volume of speech in each direction separately, and controlled frequency response for speech in each direction. The high volume provides sufficient audible sound to overcome the ambient hiss due to air entering the helmet with the result that communication may be easily maintained without shutting off the air. Controlled frequency response is especially important under conditions of deep diving where high pressure and helium-oxygen atmospheres cause the human voice to become extremely high pitched.

*Diving amplifier.*—The diving amplifier is the heart of the system and serves to amplify the voice in each direction, provides a convenient control panel, acts as a terminal board for the diving cables, and supports the tender's transmitter-reproducer unit. Each amplifier is designed to provide two-way speech from the tender to a maximum of three divers.

The case is of strong metal construction and is provided with handles for easy carrying. Three jacks for connecting to the diving cables, three jacks for connecting to power supply cables, and a control panel are mounted on the case. All jacks have screw covers for protection when not in use. The tender's transmitter-reproducer is mounted rigidly to the top of the amplifier case. The entire unit is splashproof and will withstand damp salt air without damage.

The amplifier will operate from any one of three power supplies,

Diving  
amplifier  
equipment.

namely, 110 volts (60 cycles) single phase AC, 110 volts D. C., or 12 volts D. C. It consists of one channel so arranged that all divers may talk to the tender at any time except when one of the talk keys is pressed. Speech from the tender is transmitted to each diver separately as each of the three talk keys is depressed. Sufficient amplification and control of frequency response is provided to allow the system to be used in an atmosphere of air or helium-oxygen and under extreme pressures. Two tone and two volume controls are provided in order that the frequency response and volume may be controlled separately for speech in each direction. The amplifier with the control panel, tender's transmitter-reproducer, and three receptacles is shown in plate 73A.

*Diver's transmitter-reproducer unit.*—The diver's unit consists of a permanent magnet loudspeaker that serves both as a transmitter and reproducer. The unit requires only two wires from the tender to the diver. The unit is mounted in the diver's helmet and is suspended in rubber cushions. It is designed to withstand salt water without damage.

*Power cables.*—Three 30-foot power cables are supplied with the equipment. Each has a special polarized plug and is marked for the type of power supply with which it is to be used. The diver's transmitter-reproducer and the power cables are shown on plate 73B. As the plugs on the amplifier end of the power cables serve as switches for converting the amplifier to the desired power supply, insertion of more than one plug at one time will cause short circuits and serious damage. Care should be exercised so that more than one power cable will never be connected to the amplifier at the same time.

*The combination diving amplifier and life-line cable (combination telephone and life-line cable).*—Standard diving cable supplied with amplifiers is now standard for use with all telephones, as well as with the standard diving amplifier. A section of the cable is shown on plate 14. Diving cable is furnished in 200-foot lengths and consists of a hoisting member forming a central core,

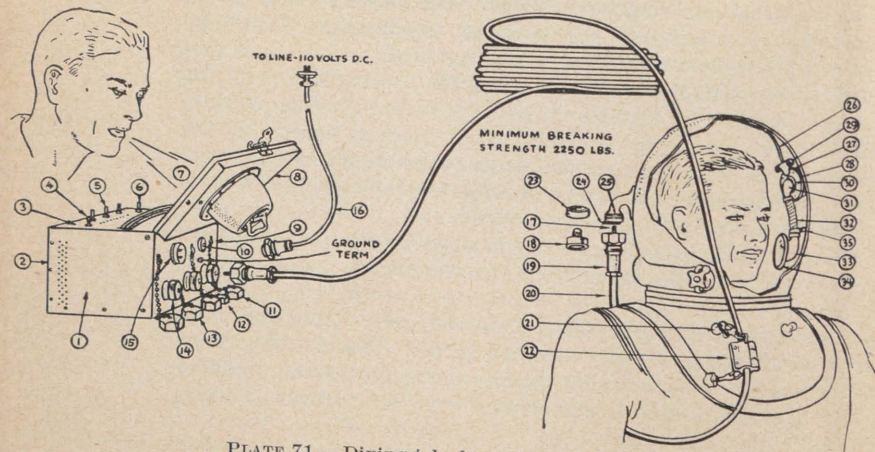

PLATE 71.—Diving telephone, amplifier type.

a rubber core jacket, four electric wires, insulated with a  $\frac{1}{32}$ -inch rubber jacket and an outer cover of tough rubber. The inclusion of four conductors in the cable provides two spare wires. The hoisting member is formed of stranded corrosion-resisting steel wire encased in a molded-rubber jacket of about  $\frac{3}{64}$  inch thick. The electric wires each consist of from 20 to 25 soft-drawn untinned copper wire strands with four dead-soft corrosion-resisting steel wire strands with a 1-inch lay. The wires are color-coded white, red, black, and green. The four conductors are spirally wound about the central core with some slack so that all

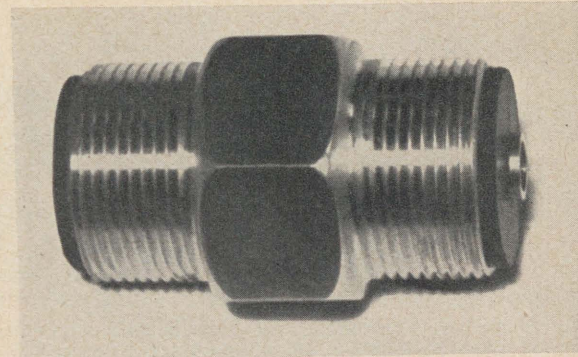

PLATE 71-A.—Diving telephone coupling, double female connection—Assembled.

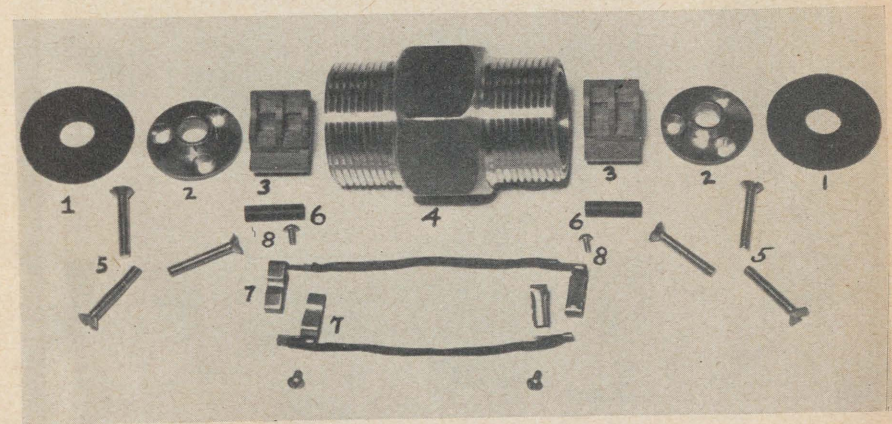

PLATE 71-B.—Diving telephone coupling, double female connection—Disassembled.

tensile strain placed on the cable is borne by the central core. The central hoisting wire, conductor wires, and inner jackets are then encased as one unit in an outer rubber jacket approximately  $\frac{5}{64}$  inch thick. The cable is about  $\frac{5}{8}$  inch in diameter, weighs about 0.35 pound per linear foot, and has a breaking strength of approximately 2,500 pounds.

Each length of diving cable is complete with two special brass plugs and one coupling. The plugs are permanently attached to each end of the cable and will make a strong watertight mechanical connection and a positive electrical connection to the diver's

helmet and to the amplifier. When additional cable length is desired, the coupling is used to connect two or more 200-foot lengths of cable together. The couplings and their constituent parts are shown on plates 71-A to 71-F, inclusive.

Precaution to be taken when using any diving communication equipment.

When diving operations are conducted from wooden rafts, hulls, or docks, the electrical equipment is often insulated from the ground. As a result of this, a static electric charge sometimes exists between the equipment and ground, and when the helmet is placed on the diver, this charge will discharge through his body producing serious electric shock.

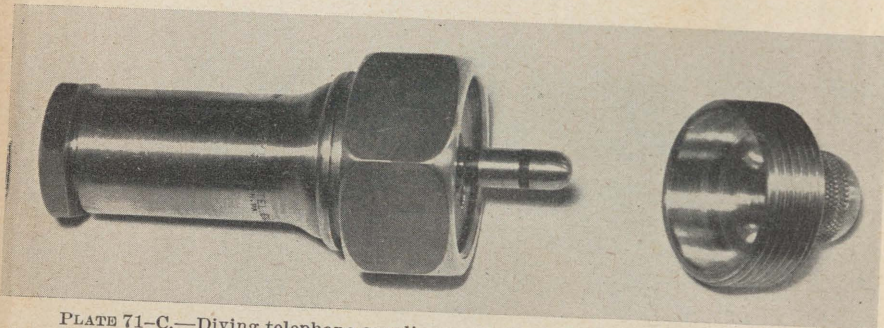

PLATE 71-C.—Diving telephone coupling, male (jack plug housing) — Assembled.

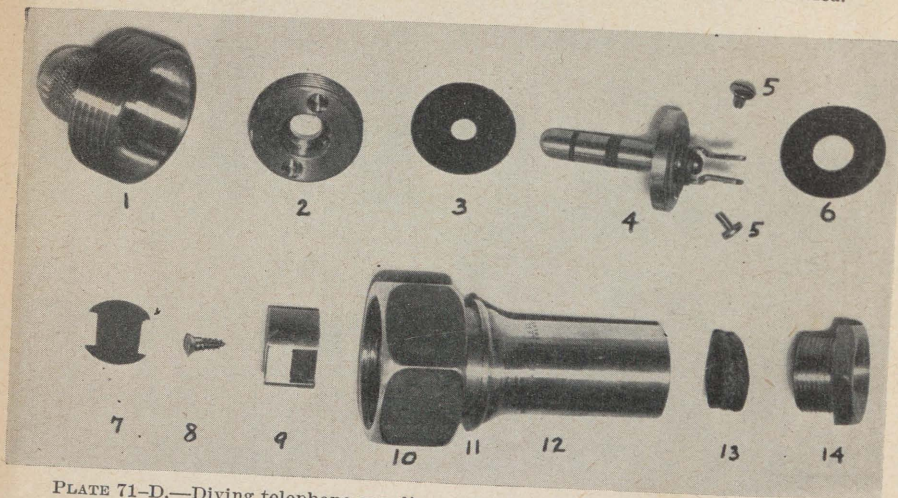

PLATE 71-D.—Diving telephone coupling, male (jack plug housing) — Disassembled.

To prevent this condition, the diving telephone or diving amplifier case should be grounded by the connection of a copper wire from a screw in the case to any metal that is in continuous contact with the water. The wire should be No. 10 B. and S. gage or larger. The diver's metal ladder will often serve as a good grounding point. If any metal sheathed cable is used to make connection to a shore power supply, the sheath should be grounded in a similar manner.

## SCHEDULE OF MATERIALS

QUANTITY	DESCRIPTION	UNIT

### GENERAL NOTES

- 1 - THE STEEL EYES SHALL BE CAST IN THE WEIGHT AS SHOWN. IT IS IMPORTANT THAT EYE BOLTS BE CENTERED IN CASTING SUCH THAT BALANCE WILL BE MAINTAINED.
- 2 - ENTIRE WEIGHT SHALL BE GALVANIZED.
- 3 - WEIGHT IN POUNDS SHALL BE CAST ON THE WEIGHTS AS INDICATED. LETTERS SHALL BE NOT LESS THAN  $\frac{1}{2}$  HIGH.

DRAWN BY: R.E. ROPER

EXAMINED BY: *J.M. H. Jones* PRINCIPAL ENGINEER

IN CHARGE OF WORK: *F.D.* DATE: 5-21-42

## STANDARD PLAN DIVER'S CAST IRON WEIGHTS

SCALE - 12" = 1 FOOT

NAVY DEPARTMENT

BUREAU OF SHIPS

WASHINGTON, D. C.

MAY 23, 1942

BU. No 525964

*C.D. Shafer*  
FOR CHIEF OF BUREAU

MARK	DATE	DESCRIPTION	APPROVED

SCHEDULE OF MATERIAL

QUANTITY FOR ONE WEIGHT						
PCNO	NAME	PCS	SPEC.	MATERIAL	DIE	REMARKS
1.	WEIGHT	1	46-I-5	CAST IRON		100 POUND
2.	EYE	1	46-S-4	STEEL	1142	
3.	WEIGHT	1	46-I-5	CAST IRON		50 POUND
4.	EYE	2	46-S-4	STEEL	1139	
5.	WEIGHT	1	46-I-5	CAST IRON		25 POUND

GENERAL NOTES

- 1 - THE STEEL EYES SHALL BE CAST IN THE WEIGHT AS SHOWN. IT IS IMPORTANT THAT EYE BOLTS BE CENTERED IN CASTING SUCH THAT BALANCE WILL BE MAINTAINED.
- 2 - ENTIRE WEIGHT SHALL BE GALVANIZED.
- 3 - WEIGHT IN POUNDS SHALL BE CAST ON THE WEIGHTS AS INDICATED. LETTERS SHALL BE NOT LESS THAN 1/2" HIGH.

DRAWN BY: R.E. ROPER

EXAMINED BY: *J.M. Johnson* PRINCIPAL ENGINEER

IN CHARGE OF WORK: *J.D.* DATE: 5-21-42

STANDARD PLAN  
DIVER'S CAST IRON WEIGHTS

SCALE - 12" = 1 FOOT

NAVY DEPARTMENT

BUREAU OF SHIPS

WASHINGTON, D. C.

MAY 23, 1942

BU. N° 525964

*C.D. Wheelock*  
FOR CHIEF OF BUREAU

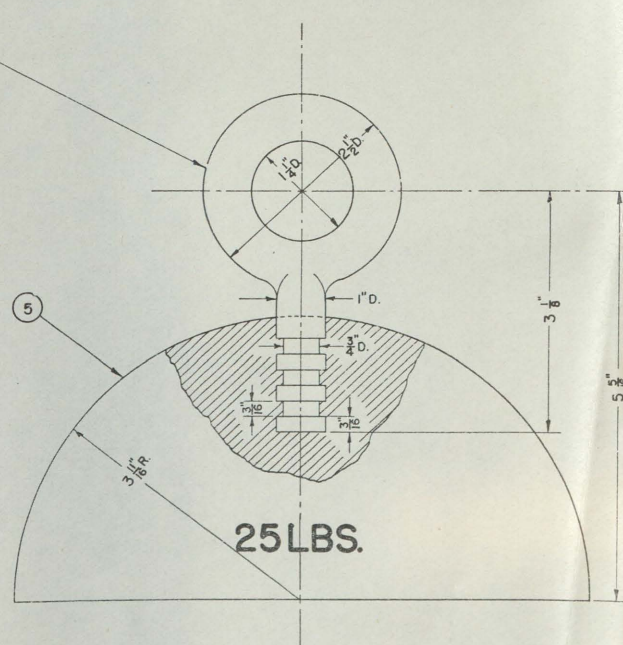
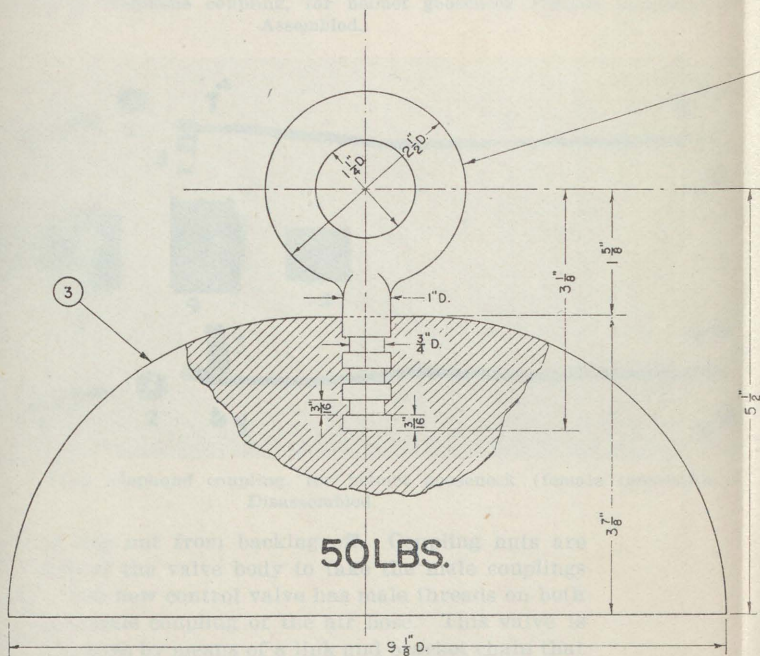
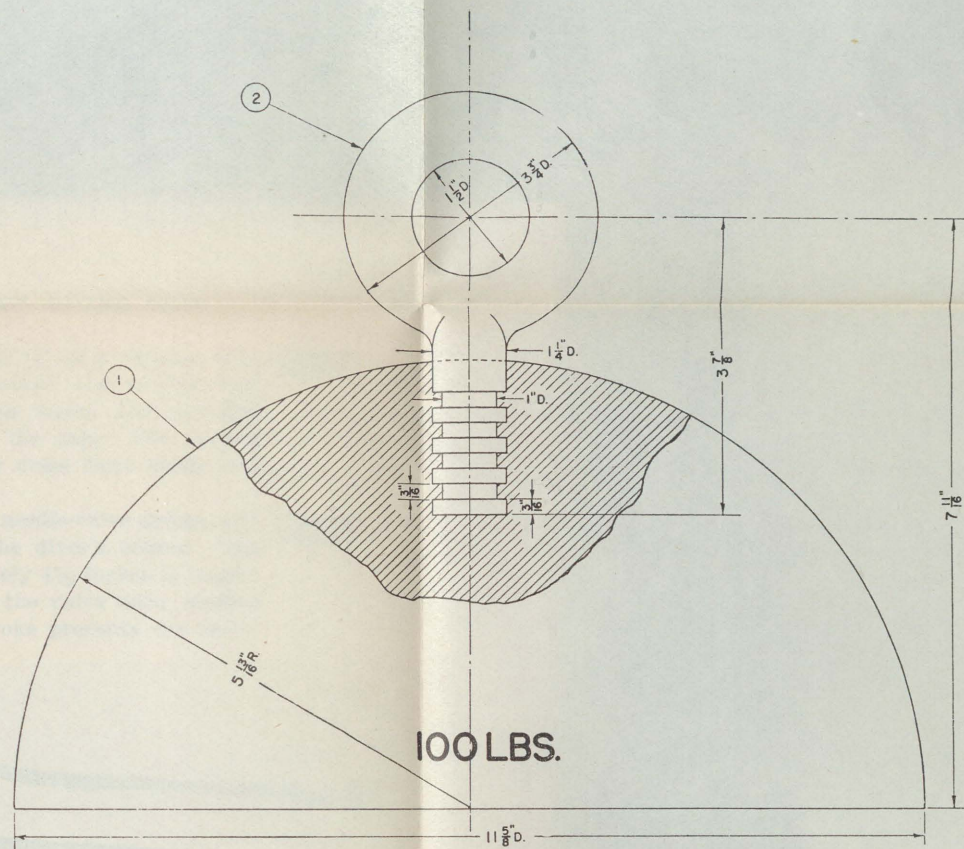

Pr  
be  
usi  
div  
mt  
equ

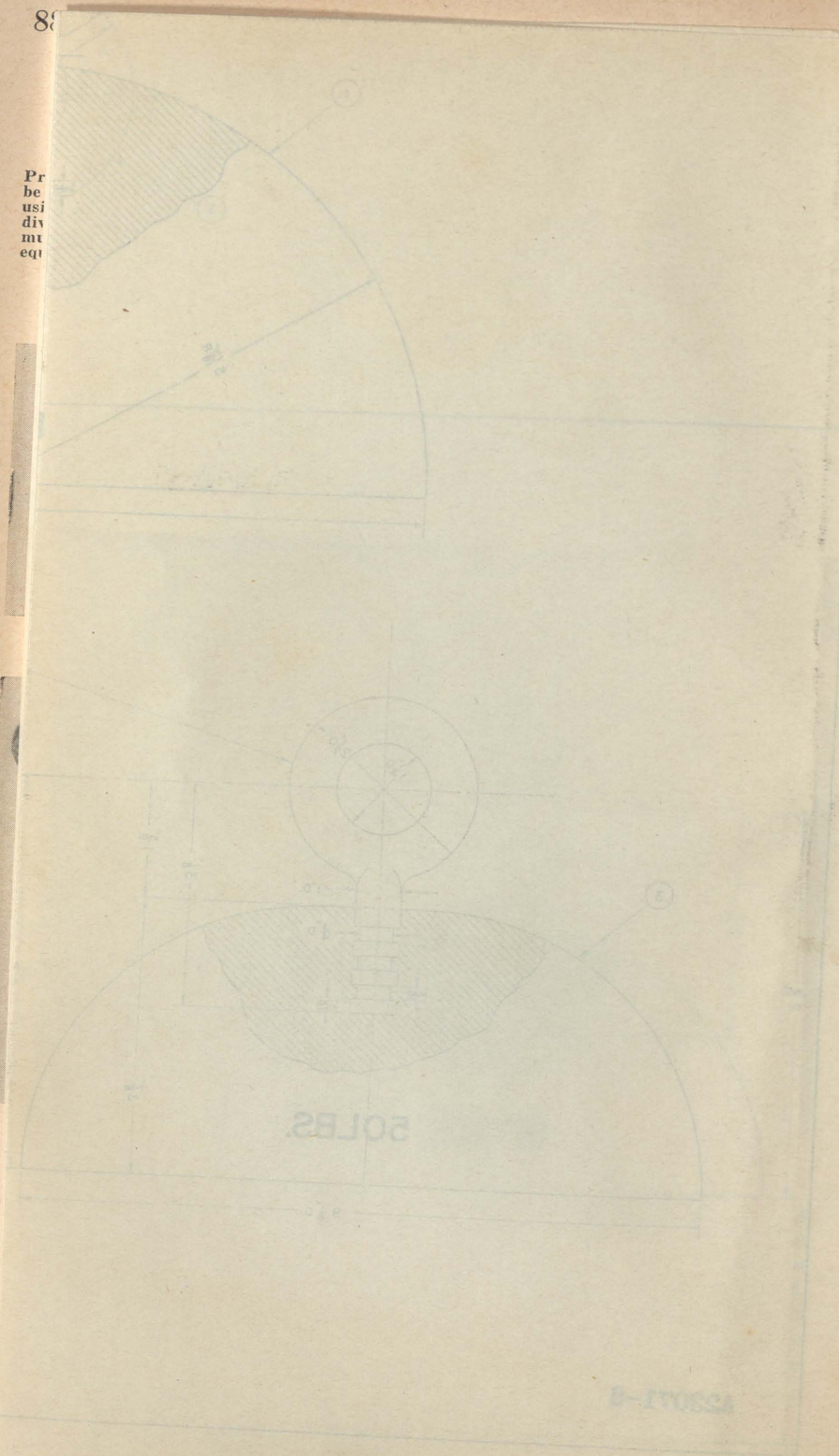

The overall trousers (pl. 74) are made of light canvas, with adjustable straps fitted with brass buckles and eyelets, two pockets, reenforced with patches over the knees, and provided with flaps and thongs for lacing up the legs. The overall trousers are used to protect the diving dress from chafe and wear.

Trousers,  
overall.

The air-control valve (pl. 75) is of the needle-valve design, and is used to control the inlet of air to the diver's helmet. The valve body is a brass casting, approximately 4½ inches in length, with a boss cast at a 35° angle to take the valve stem, stuffing box, gland, and cap nut. A retaining yoke prevents the valve-

Valve, air  
control.

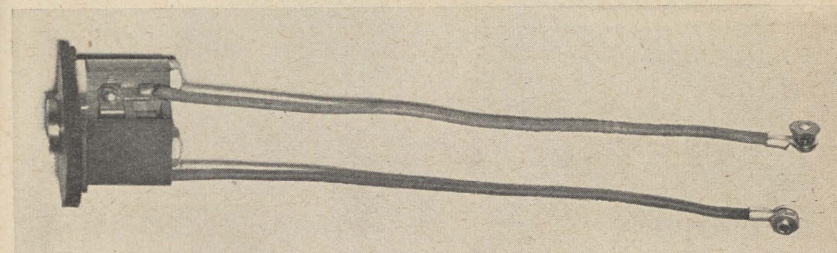

PLATE 71-E.—Diving telephone coupling, for helmet gooseneck (female connection)—Assembled.

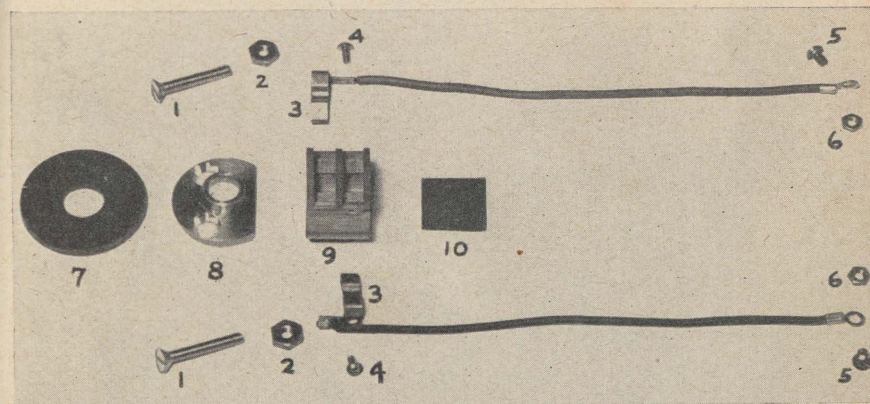

PLATE 71-F.—Diving telephone coupling, for helmet gooseneck (female connection)—Disassembled.

stem stuffing-box cap nut from backing off. Coupling nuts are spun on both ends of the valve body to take the male couplings of the air hose. The new control valve has male threads on both ends to take the female coupling of the air hose. This valve is held to the diver's dress by means of a link and bracket chain that is placed under, and secured by, the wing nut on the long stud at the lower left-hand side of the breastplate.

Cast-iron weights (pl. 76) are provided in three sizes, i. e., 25, 50, and 100 pounds. They are of mushroom shape, fitted with steel pad eyes as shown, and are painted black. The 25-pound weights are usually used as marker-buoy weights. The 50-pound weights are used with the decompression stages. The 100-pound weights are generally used as descending line weights.

Weights.



PLATE 72.—Diving telephone, battery type, and sennet-covered combination telephone and life line cable.

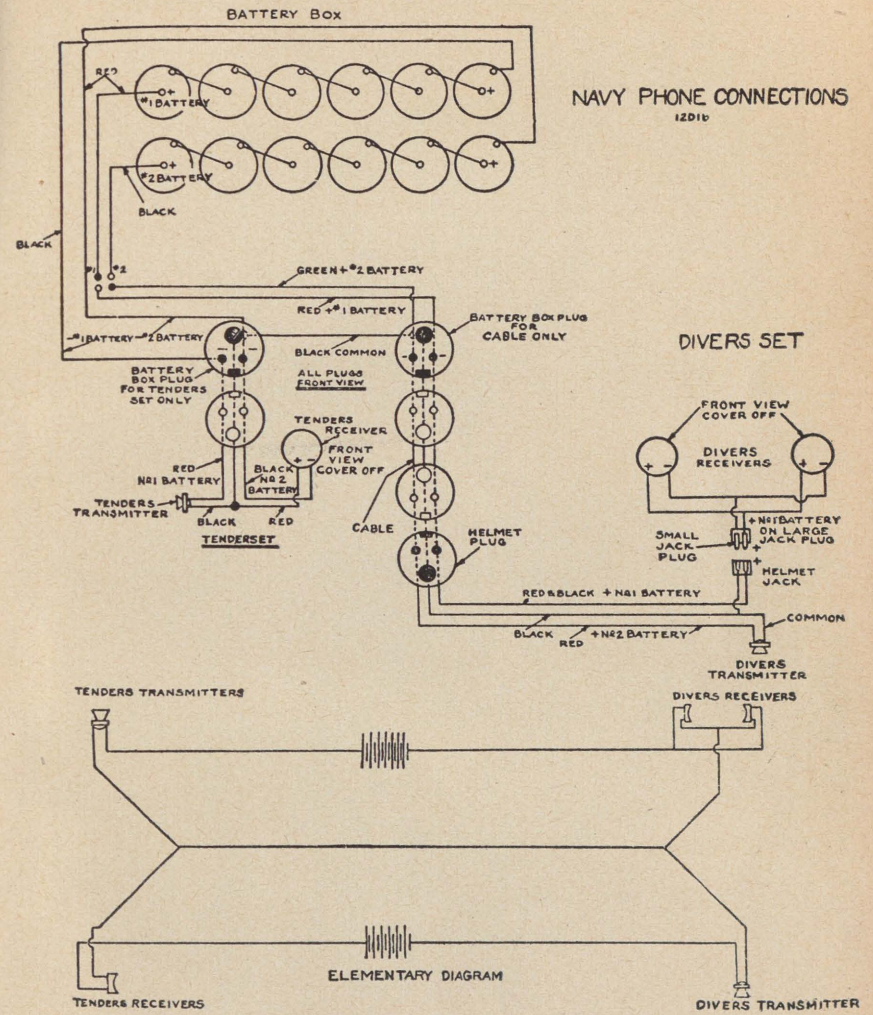

PLATE 73.—Diving telephone, battery type—Wiring diagram for.

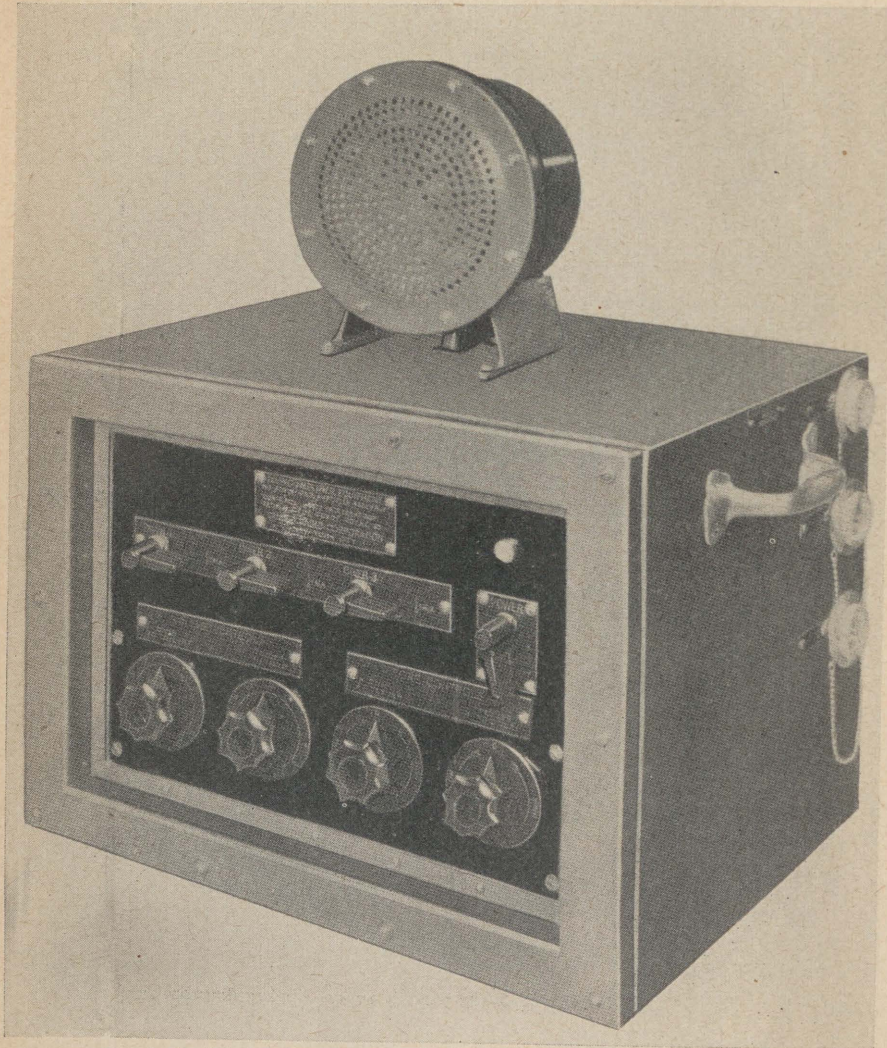

PLATE 73-A.—Amplifier and tender's reproducer—front and right side.

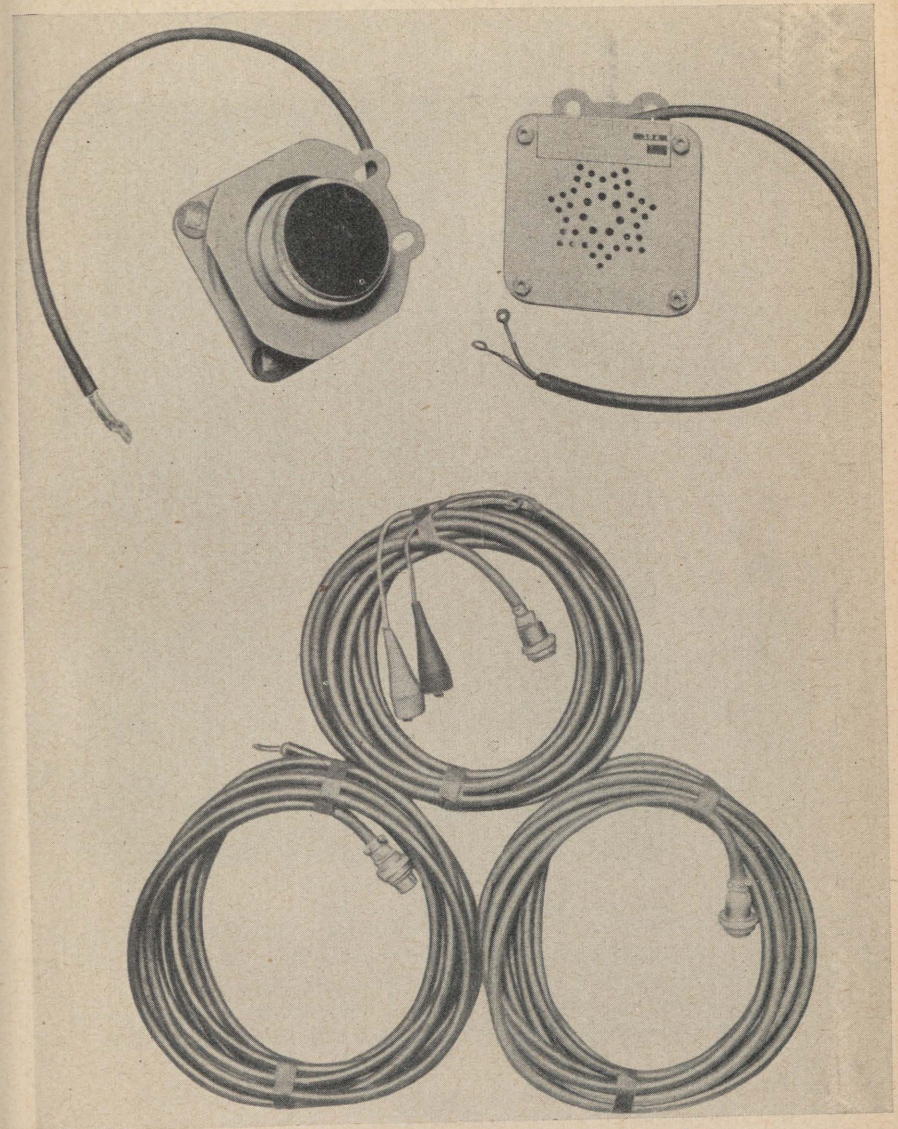

PLATE 73-B.—Diver's reproducer and power cables.

## Woolens.

Woolens consist of woolen undershirts, drawers, socks, and gloves. The shirts and drawers are worn usually over the diver's ordinary clothing when working in cold water. Woolen gloves are worn inside the rubber gloves to protect the hands from cold. The woolens are furnished in fast-dyed dark colors. The shirts and drawers are furnished in sizes from 36 to 44. Gloves are furnished in sizes 9 to 11.

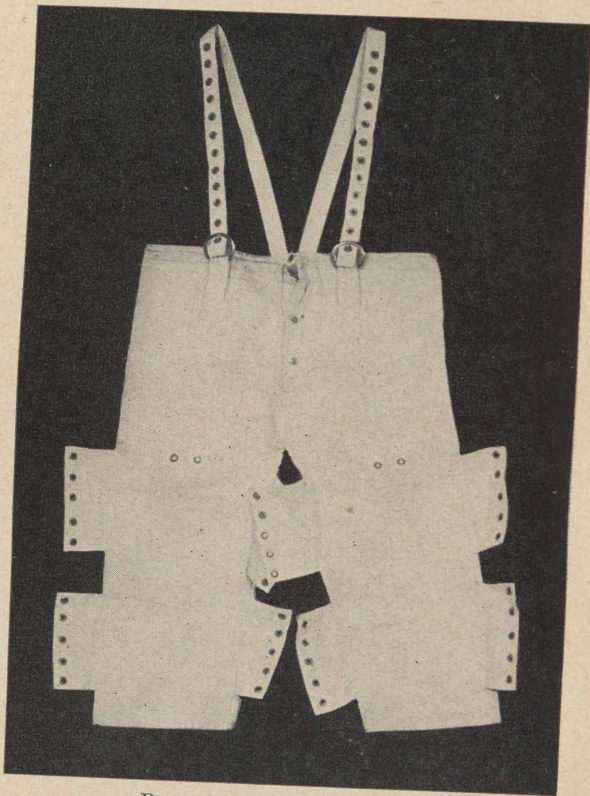
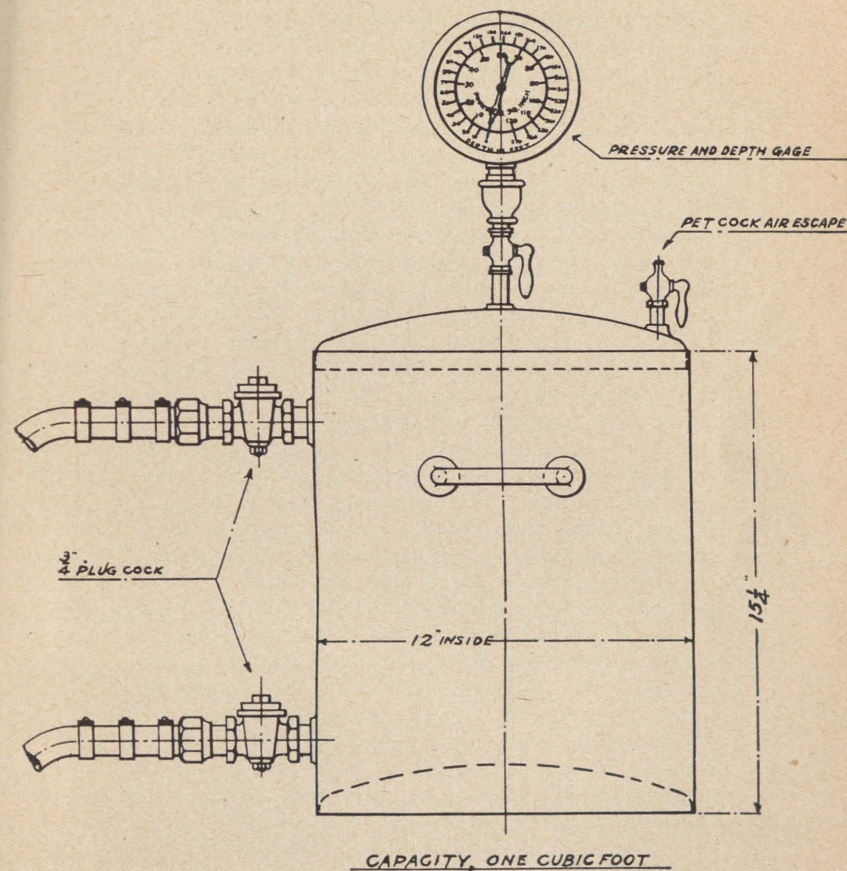

PLATE 74.—Diver's overalls.

Special gear  
not a regular  
part of stand-  
ard diving gear.

Certain other gear, such as underwater cutting torches, underwater welding outfits, underwater tools, etc., essential to salvage operations are not included in standard diving outfits but are furnished as separate and special items to submarine rescue and salvage vessels. This special equipment is described in chapter XIX.



CAPACITY, ONE CUBIC FOOT  
PLATE 74-A.—Tank, test, for diving air system.

## CHAPTER V

## SHALLOW-WATER DIVING APPARATUS

Types.

Navy shallow-water diving apparatus consists of three types—one known as the Miller-Dunn type, one as the Morse type, and one as the Ohio Rubber Co. type. Being light in weight and compact they can be transported and stowed easily. While shallow-water diving does not present the hazards involved in deep-sea diving, a real hazard does exist to the man unfamiliar with the methods and basic physiological principles of deep-sea diving. This equipment should be used only by trained divers or under the supervision of a competent officer or enlisted man trained in this field. The divers should be good swimmers. They are useful in warm water in performing such work as examining and cleaning ships' strainers, propeller work, etc. The Morse and Miller-Dunn types each consists of a helmet, lead weights attached to the helmet, 50 feet of rubber air hose, and a manually-operated hand pump. Their principle of operation is the same. Air is supplied to the helmet by operation of the hand pump at a pressure greater than the surrounding water pressure at shallow depths. The excess air pressure in the helmet prevents the water, which of course has access through the bottom of the helmet, from rising above the level of the air inlet. It is for this reason that the air inlet is located near the bottom of the helmet. Excess air escapes through the bottom of the helmet. If the helmet is tilted too far from the vertical, there is danger of all of the air in the helmet escaping and the helmet filling with water. While the diver may stoop slightly without this occurring, any tilting of the helmet in excess of 45° will allow the water to rise in the helmet above the level of the diver's mouth and nose. Likewise, if the pressure of the air supplied to the helmet is less than the pressure of the water surrounding the helmet, the water level rises in the helmet until the internal and external pressures equalize. Accordingly, care should be taken that the depths to which dives are made are not greater than those to which the pump can supply air, in volume and pressure commensurate with requirements. The Ohio Rubber Co. type consists of a rubber face mask, one nonreturn valve, 2 pairs of diver's underwear, 2 pairs of rubber sneakers, one 50-foot length of air hose, one 3-foot length of air hose, an expansion tank, and a manually-operated hand pump of the same type as supplied with the Miller-Dunn or the Morse type apparatus. Detailed instructions are furnished with the face mask outfit. With this type apparatus, the diver has greater freedom of movement, and can assume any position without water entering the face mask, provided air of proper pressure is continuously supplied to the mask. It is also easier for the diver to maintain an upright

position with this type of outfit than with the helmet types. For Navy work, use of shallow-water diving outfits is restricted to depths of 36 feet or less. A detailed description of each type follows:

The Miller-Dunn Navy type shallow-water diving outfit is shown on plate 76. Miller-Dunn  
Navy type.

*Helmet.*—The helmet of 17-ounce, hard-rolled copper is cylindrical in shape, domed on top, and made with a rolled edge at the bottom to conform with and fit comfortably on the diver's shoulders, upper chest, and back. The unweighted helmet weighs 26½ pounds, but when properly weighted, it weighs 60 pounds. A handle is riveted to the top of the helmet to facilitate handling.

The front of the helmet is fitted with a heavy bronze frame in which two plate-glass windows are located. The windows are made watertight by being set in soft wicking soaked with white lead, and are secured by right- and left-handed securing frames held to the helmet by 19 hexagonal-headed stud bolts. Each window is 10 by 5 inches, and either glass may be removed for replacement without disturbing the other. A long-top, short-bottom guard protects the glass from breakage. A male-threaded air inlet connection, termed the gooseneck, is riveted and sweated on the right side of the helmet near the bottom and is curved downward toward the rear at a 35° angle so as to give a fair lead to the air hose. An eye is formed on the curve of the gooseneck for securing the bight of the air hose.

A copper baffle plate sweated over the air inlet inside the helmet deflects the air upon entrance, causing it to pass over the faceplate and thus prevent its fogging. Small holes pierced in the bottom part of the helmet permit the escape of excess air in addition to that which escapes around the shoulders. Broad copper straps are riveted to the front and back plates of the brass clips molded in the lead weights.

Four 8¼-pound lead weights are hung on the weight straps of the helmet, two in front and two at the back, to prevent the helmet from lifting off the diver's shoulders. They are secured to the helmet by marline stops passed through holes provided in the weights.

*Pump.*—The air pump is a twin-cylinder, single-action pump that is manually-operated by a lever 37 inches long, fitted with a hardwood handle. The weight of the pump complete is 28 pounds, and is designed and constructed to supply an adequate amount of air down to depths of about 40 feet.

The bottom plate is an irregular-shaped iron casting having a vertical standard in the center to which is pinned a rocker arm or beam of the same material. This rocker arm or beam has a drilled fork end to which are pinned the upper ends of the piston rods. A socket also formed in the rocker-arm casting provided a means for holding the pump handle that is held in place by a set screw.

The vertically mounted cylinders are of seamless drawn brass, 3.375 inches in diameter, and have an inside depth of 5 inches. Each cylinder is closed at the bottom by a composition metal head screwed and sweated permanently in place. Cast with

the bottom cylinder head is a hinged lug by means of which the cylinders are pinned to the bottom of the plate. This method of securing the cylinders permits them to move slightly in a vertical plane in order to center their axis with the ends of the rocker arm or beam that makes a vertical arc on the upward and downward strokes of the piston. There is a drilled, threaded extension on the bottom cylinder heads in which is screwed the air lead connection cast in one with the valve body. Inside the bottom cylinder head, an air channel is scored out that leads to the air connection. The top cylinder head is threaded and



PLATE 76.—Shallow water diving apparatus—Miller-Dunn type.

screwed on the cylinder. Lugs cast in one with this head may be engaged by a hook spanner wrench for tightening or removal. Besides the center hole for the piston rod's passage, four other holes are drilled through the top cylinder head. These holes not only prevent cushioning on the upward stroke of the pistons, but also allow for oiling of the piston leather, for heat dissipation, and for lightness.

The piston consists of two cast disks with a cup leather interposed between them, and when properly assembled the piston has a thickness of 1 inch. Length of its stroke is 3.75 inches and stroke delivery when 100 percent efficient is 33.55 cubic inches of air.

The piston rod is 6.375 inches in length, 0.625 inch in diameter, and passes through the center hole in the cylinder head that forms a guide for it. The piston rod is threaded on the lower end and passes through a central hole in the upper disk and cup leather and screws into the threaded hole in the lower disk of the piston.

The vertical position valve bodies are interconnected by a 7-inch length of flexible rubber hose thus constituting the pump manifold. Near the manifold air connection to each bottom cylinder head is a small screw that may be removed to drain any excess oil formed in the cylinders. The upper ends of the valve bodies are closed by nuts. When facing the pump manifold, the right-hand valve body nut has an air connection for the male end fitting of the diving hose. In the lower end of each valve body is screwed a nut that has a  $\frac{3}{8}$ -inch hole drilled through its center. This hole forms the suction intake for each cylinder, and the upper inside part of the nut forms a seat for the inlet valve. The floating-type inlet valve has a short-fluted stem and a leather-washer-faced, flat seat. This valve is held seated due to its own weight and the pressure of delivery air when its respective cylinder is under compression. The valve lifts on the suction stroke permitting air to enter the bottom of the cylinder. An outlet valve similar in shape and size to the inlet valve is located in the upper part of each valve body and rests on its seat formed in the valve body. The compression stroke causes this valve to lift, and the air discharges into the air hose.

*Air hose.*—The air hose is a flexible vulcanized rubber tube surrounded by a two-ply, braided, duck covering laid in rubber that, in turn, is covered by a smooth outer layer of rubber. The hose is 50 feet in length, weighs 16.75 pounds, and has an inside diameter of 0.5 inch and an outside diameter of 1 inch. One end of the hose is fitted with a commercial threaded, brass male coupling that connects to the pump manifold. The other end is fitted with a female-type coupling that connects to the gooseneck at the helmet. The hose is marked FOR SHALLOW WATER DIVING, about 2 feet from either end with inlaid letters. The special thread used on the couplings and this inlaid marking on the air hose are precautions taken to prevent the use of the shallow-water diving hose with the standard No. 1 and No. 2 deep-sea diving outfits.

The wooden stowage box measures approximately 15 by 12

by 42 inches, and is furnished as a part of the outfit. Total weight of the complete boxed outfit is approximately 105 pounds.

The Morse type of shallow-water diving outfit is shown on plate 77.

*Helmet.*—The helmet weighs approximately 20 pounds and is made of spun copper. The upper portion of the helmet is spherical in shape and the lower portion is shaped to fit com-

A. J. Morse  
Navy type.

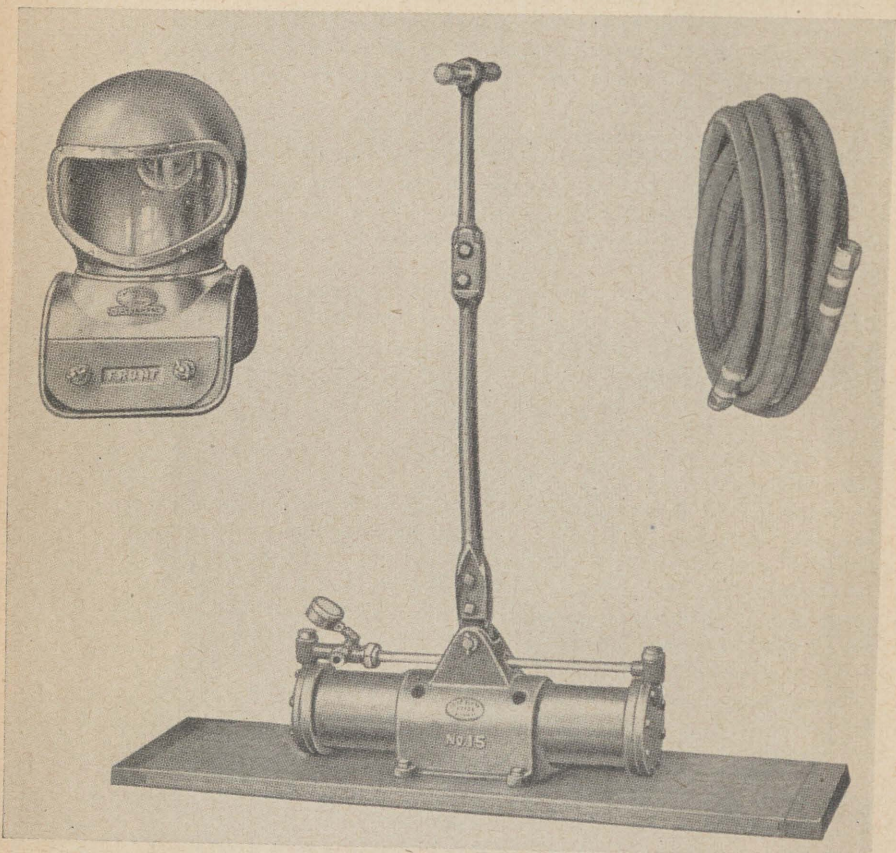

PLATE 77.—Shallow water diving apparatus—A. J. Morse Co. type.

fortably on the diver's shoulders, upper chest and back. The inside diameter of the neck portion of the helmet is  $9\frac{1}{4}$  inches, whereas that of the spherical portion is large enough to permit the diver to move his head freely. The front of the helmet is fitted with a single curved window made of shatterproof glass. The window is made watertight by being embedded in red-lead putty, in a bezel, and secured by a bronze frame that is held fast to the bezel by brass screws. No diving guard is fitted to the laminated glass window, but a brass plate stowage guard is provided, to protect the window when the helmet is not in use; it is fitted over the window and held in place by two thumb screws. The glass is  $12\frac{1}{2}$  inches long,  $7\frac{1}{4}$  inches wide, and  $\frac{1}{4}$ -inch thick, and the corners are rounded with a  $2\frac{1}{4}$ -inch

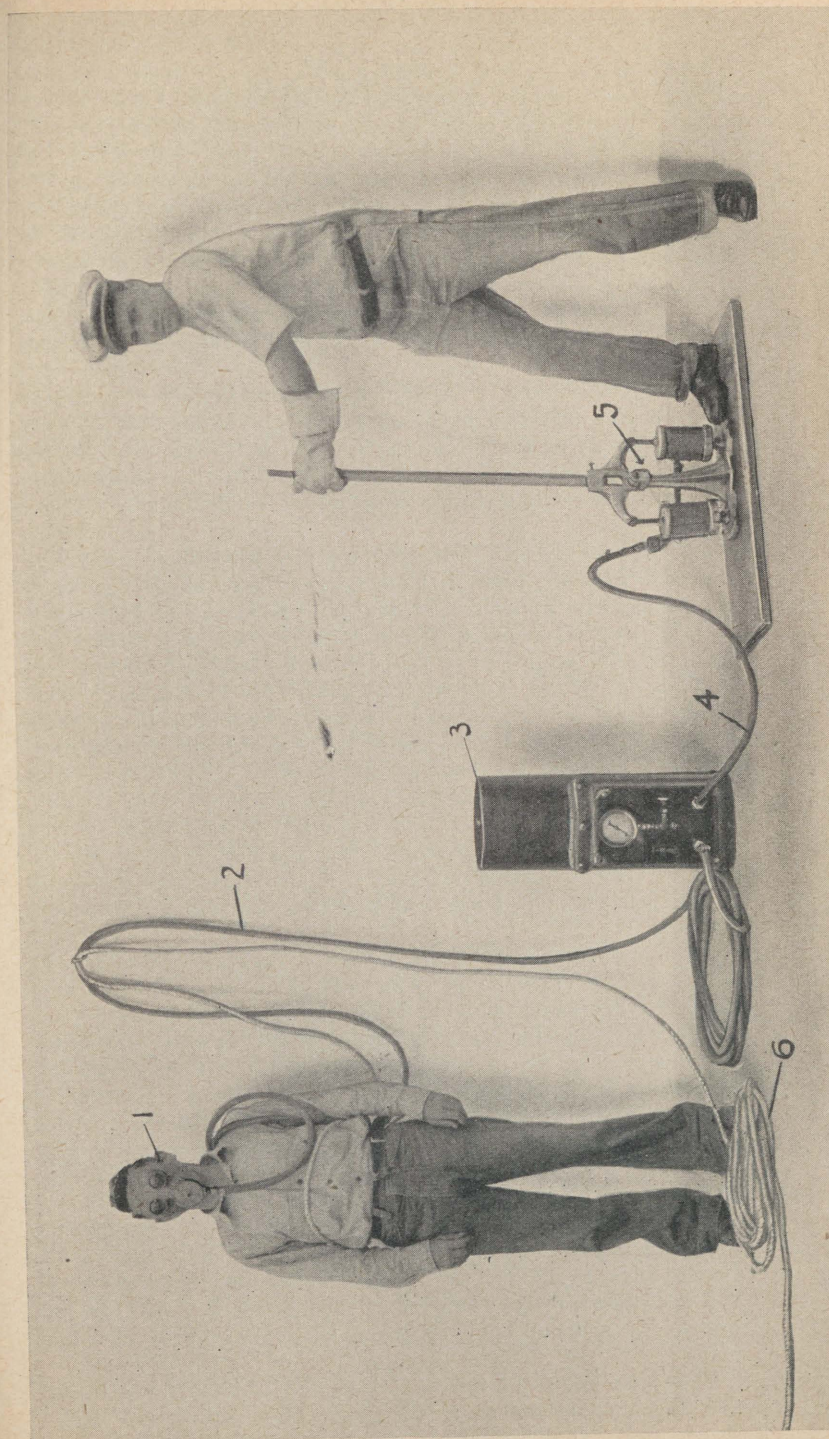

PLATE 77-A.—Shallow water diving apparatus—Ohio Rubber Co. type.

radius. The top of the window is tipped slightly forward to give the diver greater range of downward vision. Air is admitted to the helmet through a 90° elbow, turned downward at about 30° to give a fair lead to the air hose. After the air passes through this elbow located at the back of the helmet, it is conducted by two 2-inch passageways opening at either side of the window. A bronze swinging handle is secured to the top of the helmet to facilitate handling. An eyelet placed on the left-hand side of the helmet provides an anchorage for securing the air hose after it passes under the diver's left arm.

*Air pump.*—The air pump is a two-cylinder, single-action, manually-operated pump that weighs approximately 62 pounds. The cylinders, base, and handle pivot are made of a single bronze casting.

The cylinder block is secured to a plank that is 12 inches in width and of sufficient length to extend approximately 12 inches on either side of the block. This plank extension provides the operator with standing footroom when operating the pump, thereby steadying it. The inside diameter of each cylinder is 3.625 inches.

The pistons are 0.75 inch thick, and are 0.0625 inch smaller in diameter than the bore of the cylinders. They have a stroke of 3.5 inches, and a theoretical delivery per stroke of 72.84 cubic inches. The waste room is approximately 0.4 inch. Each piston is rigidly connected to its respective cast-bronze piston rod, and has cut in it a single annular groove 0.5625 inch deep. This groove is flat on the pressure side and is curved on the opposite face. Eleven 0.228-inch diameter holes are drilled in the pressure side to meet the base of the groove. Into the groove is placed an oil-saturated leather ring that stretches over the face of the piston and settles into the groove. The shape of the groove prevents the ring from reaching the bottom of the groove. The thickness of the leather ring is slightly less than the width of the groove. Oil ports are provided for oiling the piston leathers.

From the foregoing, it will be noted that the piston ring is also the inlet valve. The valve chamber is cast integral with each cylinder head. On the intake stroke, air is drawn from the rear of the piston, past the leather ring that is forced against the flat wall of the groove, and through the passageway left to the rear of the leather ring, under it, out through the 11 holes, and into the cylinder. On the reverse stroke, the leather ring clamps tightly against the curved rear face of the ring groove, and forces the air through the check valve placed in close proximity to the end of the cylinder. The air is then delivered through the respective outlet valve into the section of brass pipe that connects the outlets with a T casting. This T casting has two openings: One for the air-hose connection, and the other for the pressure-gage connection. The pressure gage when in position is set at an angle so it may be read easily by the pump man.

The piston rod is 1.5 inches in diameter, is cored for lightness, and is milled at its center to receive the forked end of the rocker arm. This rod runs in an ample bearing that is cast in-

tegral with the cylinder block, and bored at the same setting to assure perfect alinement. Oil passages are provided for oiling the piston rod bearings.

The manganese bronze rocker arm is pivoted on a 0.625-inch pin anchored in the cylinder block casting. This rocker arm operates the rigid unit composed of the two pistons and the connecting piston rods, and has an upward extension provided with a 0.75-inch cast key. This extension fits the lower section of the malleable iron operating rod. The two sections of the operating rod are similarly keyed and are held together by two bolts.

An 8-inch wooden cross handle is fitted at the top of the upper section of the operating rod. The length of the assembled handle from its pivot is 3 feet 5 inches.

*Air hose and chest.*—The air hose, hose connections, and the storage chest for the Morse apparatus are similar to those described in the foregoing as forming a part of the Miller-Dunn type of apparatus.

The Ohio Rubber Co. type shallow water diving outfit is shown on plate 77A.

Ohio Rubber  
Co., type.

*Face mask.*—The face mask (part 1) is a molded rubber face-piece secured to the face with rubber straps. These straps are secured together with a buckle at the rear. The eyepieces are of tempered glass. A "demand" type breathing valve is secured to the front of the mask, about the level of the chin and is so designed that with a constant air supply of 90 pounds pressure this valve will open only when the diver inhales. On exhalation, the valve remains closed. The valve is also provided with a push button valve which if pushed will open the demand valve thereby furnishing an easy and quick means of obtaining an access of air in the mask. The air supply line (part 2) is connected to the demand valve. A bypass valve is provided by which the diver may receive a continuous flow of air as in any other diving outfit. The mask however can be used without the demand type valve by connecting the air hose direct to the air fitting on the mask. When so connected exhaust air escapes around the edge of the mask. In order to prevent the diver's face from being squeezed in the event that the air hose becomes severed, a safety nonreturn valve is placed in the line between the demand valve and the hose coupling.

*Volume tank.*—Due to the small air capacity of the face-piece, it is necessary to include a one-half cubic foot capacity or larger volume tank (part 3) in the air supply line to eliminate the variable pump stroke pressures delivered by the shallow-water diving pump. The volume tank is not required when using compressed air from a source having a continuously steady flow or when using oxygen from a cylinder.

*Pump.*—The air pump (part 5) is similar to that used with the Miller-Dunn or Morse type shallow water diving outfits described above.

*Air hose.*—The air hose is 5/16-inch inside diameter rubber hose of the type used with oxy-hydrogen under-water cutting outfits.

## CHAPTER VI

### CARE, SURVEY, AND REQUISITIONING OF DIVING GEAR

Every effort shall be made to preserve the fine appearance of diving apparatus, to keep it in good repair and ready for immediate use. With this end in view, the instructions contained in this chapter shall be carried out in detail.

**Storage.**

Diving apparatus shall be maintained ready for immediate use. It should not be stowed in compartments below the water line or in places difficult of access in time of emergency.

All chests of diving apparatus shall, when sufficient space is available, be kept habitually stowed under cover, away from steam pipes and excessive heat. When it is necessary to keep them in the open, and exposed to the weather, suitable canvas covers shall be provided and used to protect the outfit.

**Spare parts.**

Spare parts of diving apparatus not required for immediate use shall be kept in suitable storeroom, and when drawn for use shall be replaced by new parts at the earliest opportunity.

**Leather goods.**

Unless properly cared for, leather articles used in water will soon become dry and hard and liable to crack. Finished leather contains a certain amount of oil and grease, and when this is washed out, the leather loses its flexible quality and will soon show signs of deterioration. Occasionally the leather parts of diving apparatus should be given a coat of neat's-foot oil well rubbed in, so that the articles will not be disagreeable to handle. To treat leather properly with neat's-foot oil, place the article to be treated flat if possible. Then soak a rag in oil and apply one coat of oil at a time until the oil soaks through on the other side. Do not attempt to apply the oil from both sides at once and do not submerge the article to be treated in the oil.

**Metal parts**

All metal parts of diving apparatus should be kept free of rust or verdigris, in efficient working order, and protected from injury. Special precautions are to be taken with valves, valve seats, and like parts. Parts not kept painted, polished, or galvanized should be kept lightly coated with oil.

**Rubber goods.**

As oil or grease is specially destructive to rubber, parts of diving apparatus composed of rubber must be protected from oil or grease in any form. Diving dresses, and other parts consisting of rubber with cloth coverings or cloth insertions, shall not be put away while damp or wet. Rubber materials, when folded, acquire a permanent set at the bends, and later, when used, are apt to crack open or break at these points. Such materials should as far as practicable be stowed without folding. The instructions for making repairs to diving dresses also apply to other rubber or rubberized materials.

The longevity of rubber is limited by the characteristics inherent to material of this nature. In using rubber parts of diving apparatus, preference should be given to those of the oldest date of manufacture so far as it is practicable to do so without jeopardy. For example, hose, so far as concerns its use as diving air hose, has a stipulated life limitation. The entire amount of diving air hose furnished with diving outfits is seldom required for an individual routine diving operation. Consequently when new hose is obtained to complete a diving outfit, this new hose should not be put into use until the old hose has reached its age limitation or has become unserviceable for further use.

The outfit and helmet chests, and pump case of the diving outfit shall be kept clean inside and out. They shall be finished in the natural color of the wood, and coated with clear spar varnish. All exterior brass work shall be kept clean and polished. All exterior iron work shall be kept free of rust and black enameled.

On vessels where suitable lockers in appropriate locations are provided for stowing the diving apparatus, and the hardwood chests ordinarily supplied are not required for their original purpose, the chests should be turned into store.

All cotton and woolen goods should be kept clean and dry and in repair. When not in use, they should be stowed with a larvicide such as naphthalene and kept tightly wrapped in paper. Dirty woolens should be washed with soap and tepid fresh water, thoroughly rinsed of soap, and carefully dried.

Upon receipt of diving outfits, in whole or in part, the gear shall be carefully inspected, tested, and made ready for immediate use in every detail. It shall thereafter be maintained in the best possible state of efficiency.

When it is known that the commanding officer is about to inspect the parts of the ship in which diving apparatus is stowed, the apparatus shall be conveniently arranged for his inspection; all chests shall be unlocked, the covers opened, and men standing by to exhibit the contents as he may require.

All diving apparatus, except spare parts, shall be inspected once each week for cleanliness, conditions of stowage, etc. The diving air pump shall be hove around several times; if a power driven air pump is provided it shall be run or jacked over; helmet valves, faceplates, and fittings examined; telephone batteries (if telephones are of battery type) tested; diving dresses inspected for damage or dampness, and repaired and aired, if necessary; dirty woolens washed and dried; oil separators cleaned, if necessary, and their filters washed in hot water and dried; diving knives and their cases, all tools and metal fittings cleaned and lightly oiled; diving shoes, belts, etc., attended to; lengths of air hose that have been coupled together a long time shall be parted, the coupling threads lightly oiled, cleaned of grease or dirt; the interior of all chests cleaned of any oil, grease, or dirt.

All diving equipment on board ship shall be closely inspected once each month. Each outfit shall be inspected as to its completeness and serviceable condition and the satisfactory condi-

**Woodwork.**

**Woolens.**

**Initial inspection.**

**Commanding officer inspections.**

**Weekly inspections.**

**Monthly inspection.**

tion and allowed quantity of spare parts assured. At this inspection the efficiency of the diving air pumps shall be proved and recorded in the ship's diving log book. On ships using accumulators, air banks, or other similar sources of compressed air supply, the systems shall be checked for their efficiency and satisfactory operation. Deficiencies shall be corrected and the results recorded in the diving log book. Air-regulating escape valves, air control, safety, and nonreturn valves of the diving helmet, and all valves of the diver's air supply system shall be tested for satisfactory operation. Recompression chamber valves and gages shall be operated and checked for efficiency. Diving telephone systems shall be checked and tested. Motor launches used for diving boats should be examined to insure that means for securing the diving air pumps are in place and in suitable condition. Where such boats are equipped with air flasks for use in lieu of pumps, the system should be examined to insure that the number of flasks, piping, gages, test tank, etc., conform with the standard arrangement shown on plate 85.

Diving belts,  
weighted.

After use the diving belt should be thoroughly dried. Before storing, the buckles should be cleaned and given a thin coat of light oil. The belt and straps, if stiff, should be treated with neat's-foot oil. Leather, unless properly cared for, deteriorates rapidly and such deterioration is not always discernible from visual examination. Consequently, the belt straps including the shoulder and jock straps should be tested for tensile strength. This may be accomplished by securing a regular diving belt buckle to the overhead, run the strap to be tested through the buckle; then have a man of about 160 pounds weight gradually put his entire weight on the strap. Straps in satisfactory condition will withstand the load. In the past, the majority of failures have occurred in the vicinity of the hole punched in the strap for the grommets taking the buckle tongue. Defective or deteriorated belts should be replaced by requisition.

Diving dress.

After use the diving belt should be thoroughly dried. Be inside, or body waste odors prevail, wash with clean water inside and out, turn the dress inside out and hang up in the shade to dry. When dry, the dresses should be turned right side out, the outside dried, repaired if necessary and the dress hung up in the locker or diving room. If the dress has been used in salt water, it should be washed off in fresh water. An easy and efficient mode of drying the diving dress is to take two wooden battens about 8 feet long, secure them together in the form of St. Andrews cross, place them inside the dress, and pass another through the arms to keep them distended. The dress is then leaned at a slight angle until it is dry. On no account must a dress be packed away in a damp state; they must be thoroughly dried inside and out—otherwise they will mildew and become rotten.

When diving dresses are to be worn for rough work, the canvas overalls shall be worn over them as a protection against chafe and wear.

Diving dress  
repair.

Repair cloth is furnished with diving outfits for patching diving dresses when necessary. To patch a diving dress, the de-

fective portions to be cemented must be thoroughly dry and free from dirt or grease; lift the surface cloth by loosening with benzine; then roughen the under surface rubber of the dress with sandpaper or emery paper; apply three coats of rubber cement preferably with a small clean paint brush, each coat being allowed to dry 45 minutes. Prepare the patch by cutting a piece of the repair cloth about one inch larger on all sides than the exposed rubber surface on the dress to be patched; remove sheeting wrapping protection cloth from the patch, loosening it, if tightly adhered, with benzine; swab the exposed surface with benzine and apply one thin coat of rubber cement allowing same to dry for 45 minutes. Before applying the cement the patch may be temporarily secured with tacks to a flat board to prevent the edges from curling. Next lay the edge of the patch on the exposed rubber cemented surface of the dress, then gradually work the patch down onto the dress, using the fingers so as to remove all wrinkles and air bubbles. Next subject the repaired part to pressure either by the use of a hand roller, rolling tool, or flatiron. If any part of the edge of the patch does not appear to be adhering thoroughly and is inclined to curl, trim the loose part with sharp scissors.

Tears in the collars of diving dresses are usually confined to vicinity of the bolt holes. If a bolt hole becomes torn, the tear should be sewn together with herringbone stitches, the needle holes filled with rubber cement and allowed to dry, after which a patch should be cemented around the damaged hole on either side of the collars. The rubber collar is sewed onto the inside layer of cloth as well as being cemented in place, at the time of manufacture of the suit. Replacement of rubber collars by ships' forces is not approved.

Collar repair.

Attachment of cuffs to the diving dress is accomplished in the manner prescribed for patching the dress, except that the edges of the cuff are recemented if necessary and a thin strip of repair cloth is cemented on over the joint formed at the end of the sleeve and the edge of the cuff.

Cuffs, attach-  
ing of.

To attach gloves to the dress: First, remove the rubber cuffs; next, with the sleeve plugs (pl. 80) in place, clean and prepare as described for patching under dress repair, about 2 or 3 inches of the end of each sleeve. The wrist of each new glove is cut off as follows: 1 inch for No. 3 dress, 2 inches for No. 2 dress, and 3 inches for No. 1 dress. Two or three inches of the gauntlet part of each glove is turned back, roughened, cleaned, cemented, and stretched over the small end of the sleeve plug, up to the edge of the respective sleeve and with the thumb of the glove on a line with the top or outside seam of the diving dress sleeve. Prepare the surface turned back on the gloves and the sleeves at the same time, and when both surfaces are ready, roll the turned back part of the gloves in place over the prepared sleeve surfaces. After 48 hours has lapsed, strips of patching cloth about 2½ inches wide are cut, prepared as for patching, and fitted without wrinkles over the joint of the glove and dress so that the ends of the strip will overlap each other about 2 inches. After the lapse of another 48 hours, the sleeves are turned inside out, and in the same manner, cover the inside

Glove  
attachment.

glove dress joints. Unless emergency requires it, do not use the dress for another 48 hours.

**Glove repair.**

To repair a glove: First, remove the worn fabric from the glove, and prepare the exposed rubber in the same manner as described for dress repair. Cut patches for the glove according to the patterns shown on plates Nos. 78 to 81 as necessary. Prepare the patches and rubber surface of the glove at the same time. When both are ready, have an assistant put on the glove and half close his hand to conform to the natural molded curvature of the glove. The thumb patches are then applied, care being taken to smooth out all wrinkles. Palm patches, if necessary, are next applied, and the wrinkles smoothed out along the entire surface of the patch. Clip off rough edges of the patches and remove glove. The glove should be allowed to set at least 48 to 72 hours before using.

**Helmet and breastplate.**

The helmets shall be kept habitually screwed onto their respective breastplates, and the wing nuts lightly screwed onto the studs to prevent damage to the threads. The blank cap should also be screwed on the telephone gooseneck.

When in the diving boat and not actually in use, the helmets should be placed right side up on the helmet rack to keep them from being knocked around and to protect the internal telephone units from dampness.

Before being stowed away in their chests or in the diving apparatus room, the helmets should be wiped over inside and out with a dry cloth to prevent an accumulation of moisture from rusting the diaphragms of the telephone units. Neglect of this precaution soon renders a diving telephone system useless.

The lens of faceplates should be checked to see that it is firmly imbedded in its red lead and litharge seat, and that the lens is not cracked.

Examine the faceplate hinges, hinge pins, rubber gasket, and knife edge for defects. If the seat for the wing nut on the front faceplate is not countersunk, have it so modified before the helmet is used.

Check the spit cock to insure that its valve functioning parts are sufficiently tight to prevent accidental opening of the valve. Insure its stop pin being in place and the air duct clear when the valve is open.

Inspect gooseneck washers and see that the telephone connections are made up watertight.

Examine the helmet lock and its stopgap for defects.

See that the neck-flange gasket of the breastplate seats is even all around, and see that it is treated with neat's-foot oil occasionally.

See that the screw threads of the bayonet joint are free of burrs and other defects.

Inspect the breastplate studs for defects and tightness and see that the nuts turn freely on them. Special care should be exercised to see that the breastplate straps do not become bent or injured, thus saving an endless amount of trouble in making a tight joint at the junction of the diving dress and breastplate.

See that the lanyards are in good condition.

See that all metal parts are free from verdigris and corrosion.

If necessary to use oil for cleaning purposes, the oil should be removed and the surfaces rubbed with clean rag.

If, as a result of wear, a helmet when screwed onto its breastplate will go so far round to the right that the safety locking catch at the back is past its recess, and the faceplate is not directly in front of the diver's face, one or more paper washers should be cut and inserted under the neck-flange gasket on the breastplate or a new gasket should be fitted.

**Wear of helmet neck-flange gasket.**

The helmet valves and fittings must frequently be overhauled and the parts of valves lightly oiled. The proper functioning of the safety (nonreturn) valve is most important and it shall always be carefully tested before a diver is permitted to descend. It should be examined frequently by disassembling it and removing all verdigris. The leather valve disk should be inspected for wear or tear, cleaned, and given a coating of neat's-foot oil. The valve spring and valve stem also should be given a light coat of oil. To test the valve after assembly screw it in the reverse manner onto the end of a length of air hose, attach the hose to a diving pump and pump air into the hose. Immerse the valve in water, and note if any bubbles of air issue from the valve. If none appear, the valve is tight; if not tight, a new valve leather or spring, or both, should be installed and the test repeated. When screwed in place on the air connection of the helmet, the valve should be tried to see that it works freely and seats smartly upon release of pressure. Verdigris sometimes causes the valve to be sluggish in its action, the spring may be weak, or the follower nut may not be screwed all the way down. The inside diameter of the gasket between the valve and gooseneck should be checked, as it is possible, by setting up tight on the valve, to spread the gasket so that its edge is forced into the air passage, thereby greatly restricting the flow of air to the diver. If these precautions are carefully observed, the safety valve can be absolutely depended upon in an emergency; if neglected, the safety valve may fail at a critical time with disastrous results.

**Helmet safety valves.**

The air regulating exhaust valve should frequently be inspected to insure that it is clean and lightly oiled, that the exhaust tube is clean, and that the valve seat is tight. The secondary spring should open when the pressure on the seat exceeds the outside pressure by 2 pounds. It is extremely important that this valve be frequently and carefully inspected. A failure of the air regulating escape valve may result in "blowing up" of the diver.

**Helmet, air regulating escape valve.**

Before putting a pump away it should be tested and repaired if necessary, the water cistern drained by unscrewing the water drain-off nut and cleaned of any excess oil or grease. The wheels should be unshipped and the shaft-protecting caps belted in place.

**Pumps, air; No. 1 outfit; draining of cisterns.**

A common error is the use of an excessive amount of oil in the cylinders of diving pumps. This causes oil to be carried

**Cylinder lubrication.**

Piston and crankshaft lubrication.

over into the air hose, and oil or grease causes rapid deterioration of any rubber material with which it comes in contact.

On each cylinder cover of a diving air pump is a small oil cup for lubricating the pistons, which is done as follows: A piston is brought to the top of its cylinder, the oil cup filled with neat's-foot oil (nonodorous), and the cup is then opened. The crank is revolved until the piston is forced to the bottom of the cylinder, sucking in the oil as it descends. The oil cock is then closed; if the cock were left open, the cylinder would deliver no air on the upstroke. When the pump is in use, one such oiling for each cylinder per day is ample; when laid up, once a month will suffice. During the operation of a diving air pump a few drops of lubricating oil should be placed in each of the crankshaft bearing oil cups. The piston rods should also be lightly oiled; however, nothing but neat's-foot oil or a mixture of neat's-foot oil and olive oil in equal parts should be used for this purpose, lest an injurious oil work its way into the cylinders, contaminate the air, and affect the divers.

Air reservoirs; cleaning of.

Once a month, and oftener if they have been used much, the air reservoir cover plates of diving pumps should be removed, the air reservoirs thoroughly cleaned of excess oil or grease, and the bottom outlet valves looked after.

Lignum vitae handles should be well shellacked, polished and, when in use, the pump-shaft handle should be kept well lubricated with a mixture of oil and graphite.

Pump handles and pump-handle shafts; finishing and lubrication of.

Pump gages; test and correction of errors.

It is most important to know the errors of the gages on the diving pumps, especially when testing the pumps, and when decompressing a diver. The gages should be tested once a quarter, and more often if error is suspected, by one of the following methods:

(a) Connect two or more lengths of air hose together; join one end of the coupled lengths to a delivery nozzle of the diving air pump commencing at the free end, mark the hose at every 10 feet, if not already marked; attach a weight to the free end and with the pump heaving round, lower the end of the hose under water until the first 10-foot mark is awash. Then stop the pump, tap the gage, take its reading, and record it. Heave round the pump again, lower the hose an additional 10 feet, take and record the gage reading, continue process, etc.

(b) The air hose must, of course, hang up and down in the water, so the test should be done at slack water or, if a boat is to be used, if may be allowed to drift with the tide.

(c) Another and more accurate method of testing the gage is to use the dead weight gage testing outfit furnished the engineering department of your ship.

(d) The results are to be tabulated, as per the following example, and a table of the errors pasted on the inside of the cover of the pump chest, where it can readily be referred to.

Result of test of left gage

[Sept. 24, 1935]

True depth	Gage shows—
<i>Feet</i>	<i>Feet</i>
10	15
20	24
30	33
40	43
50	52
60	62
70	71

NOTE.—The gages on diving air pump can be changed over so as to bring the more nearly accurate one to the left-hand side; it is the left-hand gage that is most used.

A certain amount of waste room in all diving pumps, such as piston clearances, etc., is unavoidable; however, air leaks, due to faulty pistons, worn valve leathers, poor connections, etc., can be remedied. If not remedied, the leakage of air will rapidly become worse, and in time bring down the efficiency of the pump to zero when it is operated against pressure.

Remedying leakage and testing efficiency of air pumps.

The percentage efficiency of diving air pumps should be frequently checked. It can be practically and approximately determined by pumping air into an air tank of known capacity, noting the number of revolutions required for the different pressures, and then, in accordance with the following formula, making a mathematical comparison of the results thus obtained, with the theoretical capacity of the pump at the test pressures. A test tank of 1 cubic foot capacity is furnished with all new diving outfits for this purpose.

When:

T=Theoretical capacity of pump in cubic inches per revolution.

P=Test pressure in pounds per square inch (absolute).

C=Capacity of test tank, air hose, and air space in pump connections.

14.7=Pressure in pounds per square inch at 1 atmosphere.

R=Theoretical number of revolutions required to charge test tank to P.

X=The number of revolutions actually required to charge test tank to P.

then:

$$(1) \frac{CP}{14.7} = R$$

$$(2) 100 \frac{R}{X} = \text{percent efficiency.}$$

$$(3) 100 \text{ minus percent efficiency} = \text{percent loss of efficiency.}$$

The theoretical volumetric capacity of the Mark III Navy standard diving air pump per one revolution is 405 cubic inches. The volumetric capacities of air spaces contained in the air connections (capacity of branch pipe, gage pipe, air reservoirs, etc.)

Theoretical volumetric capacity of diving air pump, air hose, etc.

are 83 cubic inches. The capacity of a 50-foot length of standard diving air hose ( $\frac{1}{2}$ -inch internal diameter) is 117 cubic inches. In using the test tank as a reservoir for measuring the volume of air furnished by a diving pump, the capacity of the air hose connections between the tank and the pump and the capacity of the air connections of the pump must be added to the capacity of the test tank.

For convenient reference, the following table has been compiled and shows the approximate losses of efficiency at different percentages on different revolutions of the Mark III Navy standard diving air pump in service when tested in the manner prescribed to 100 pounds gage pressure per square inch, using a test tank of 1 cubic foot capacity and a 50-foot length of air hose between the tank and pump.

Revolutions:	Percent loss of efficiency
32.4	0
34.1	5
36.0	10
38.1	15
40.5	20
43.2	25
46.3	30
49.9	35
54.0	40
58.9	45
64.8	50
72.0	55
81.0	60
92.6	65
108.0	70

When testing an air pump for efficiency according to this method, errors are easily made in recording the exact number of revolutions required for a given pressure; therefore, each test should be repeated two or three times and the average results thus obtained should be taken as the true result. On account of the heat generated when compressing air and the consequent increase in volume due to expansion on account of the heat, cooling water should always be used in the water cistern of diving air pumps, when they are being operated against pressure.

If, after testing a diving air pump, it is found to have decreased in efficiency more than a reasonable percentage from the above requirements, the pumps should be carefully examined for air leaks, and if, after examining the valves and air connections, these are found to be tight, the cause of the additional loss of efficiency may be ascribed to the pistons, which most likely are in need of new leathers.

Spare piston leathers for diving air pumps are sometimes a trifle large and when assembled on the piston cannot be entered in the cylinder. In this case the piston assembled on its rod should be centered on a lathe and a light cut taken off the leathers to make the diameter of the piston equal the internal diameter of its cylinder. This operation must be done very carefully; a sharp

Fitting new  
piston leathers.

tool must be used to turn down the piston. Also a piston must fit very neatly in the cylinder and the length of the piston must be such as to leave only a very small clearance in the cylinder with the piston on the down stroke. If the piston is found too short, leather, paper, or thin metal disks must be added, as necessary, and if too long some of these should be removed as necessary.

The illustration, plate 61, shows the assembly of the diving air pump piston and should be referred to, if necessary, when the pistons are to be overhauled.

The diving air-pump valves, particularly the bottom outlet valves, are sometimes found to leak, due to injury of the valve leathers, dirt or grit on the valve seats, or to injury of the valve seats. These troubles are readily apparent upon inspection. The bottom valves can be examined or repaired by laying the pump on its side and removing the air chamber covers which are held by hexagon cap screws. The suction and outlet valves can then be removed with a monkey wrench. The valve stems of both valves are interchangeable. When the valve stem is used on the suction valve, the brass spring is reversed and a nut and pin added. An air leak around the transfer valve can be detected by the following method:

Connect the testing tank to an air supply (another diving pump): Place a nonreturn valve (helmet safety valve) in the air-supply line to the test tank; connect the outlet nipple of the test tank to the right-hand air-delivery nozzle (opposite the transfer valve to be tested); pump air into the test tank until the gage records considerable pressure. If all the connections are tight, the nonreturn valve does not leak, and the pressure in the tank, as indicated by the gage, decreases steadily, it is proof that the transfer valve leaks. The services of a skilled mechanic should always be obtained to repair a leaky transfer valve as this type valve is very difficult to repair.

The labor of operating a hand-driven diving air pump increases much faster than the increase in pressure of air being delivered—hence if a pump is found not difficult to operate against pressure, that pump is in need of immediate repair; however, on the other hand, any one or a combination of the following conditions will unnecessarily add to the labor of pumping:

- (a) Crankshaft bearings, brasses set too tight.
- (b) A bent crankshaft.
- (c) Stuffing box gland nuts set up too tight.
- (d) A bent piston rod.
- (e) Lack of proper lubrication.
- (f) Grit or dirt in bearings.
- (g) Transfer valve improperly assembled.
- (h) Pump-wheel handles too short.
- (i) Pistons striking on down strokes.
- (j) Pump improperly secured.

While the remedies suggest themselves, the following hints may be of value, remembering always to replace parts according to the marks:

Crankshaft bearings should be set up carefully; just tight enough to prevent end play of the shaft or to eliminate knocking.

Piston  
assembly.

Leaky pump  
valves.

Other condi-  
tions contrib-  
uting to air-  
pump deficiency  
and remedial  
repairs.

If reference marks are lightly scribed across bolt heads and onto a permanent part, they can be returned to their original setting without difficulty.

If it is suspected that a crankshaft is bent, this can be determined by centering the shaft in a lathe and checking its alinement between bearings.

To adjust the setting of stuffing-box gland nuts, slack up the nuts, blank off air-delivery nozzles, pour a little neat's-foot oil around the piston rods, revolve flywheel on pump, and watch for air leaks around the rods which will be indicated by oil bubbles. Set up on the gland nuts, a little at a time, until the leaks disappear. Occasionally the piston-rod glands should be repacked.

If it is suspected that a piston rod is bent, this can be determined by the same method as suggested above for determining alinement of the crankshaft.

If the deficiency is due to lack of proper lubrication, parts should be lubricated in accordance with instructions in the foregoing paragraphs. The transfer valve may be assembled in any one of four positions, only one of which is the correct one. If it is incorrectly assembled, it may allow all the air from the right-hand cylinder to exhaust into the atmosphere, or, in a different position, it may blank off the right-hand cylinder entirely. It should always be tested after assembly, by moving the transfer valve-rod handle to different positions and noting if the air delivery corresponds to the markings on the direction plate under the valve-rod handle.

For testing diving air pumps, they can be secured to a wooden deck by nailing a wooden cleat to the deck on each side of and against the pump case. For the approved method of securing air pump in a diving launch see plates 82 and 83.

A gasoline driven diver's air compressor is now being supplied in lieu of the hand-operated diver's air pump (plate 81A). The instructions for operating and servicing this pump are packed with each unit.

Diving air hose deteriorates rapidly and the deterioration is accelerated if the hose is stowed in hot spaces.

Special care should be taken to protect air hose from mechanical injuries and from contact with oil or grease.

If diving hose has not been used for a protracted period, it should be tested before being used, the internal test pressure to be at least 50 percent greater than the maximum pressure of the dive, held for a period of 30 minutes.

Specifications under which diving air hose is purchased require that the date of its manufacture be not more than 6 months previous to its date of delivery. The manufacturer's name, date, of manufacture, and the word "Divers" are molded in the rubber, 4 feet from each end of the lengths of hose. Air hose over 3 years old should not be used as diving hose.

Diving hose in store over 2 years old is surface inspected and hydrostatically tested before issue to 75 percent of the pressures stipulated in the Navy specifications for new hose. When diving air hose is issued by a yard, the yard should furnish the receiving activity with a copy of the report of the last test made on the

Gasoline driven  
diver's air  
compressor.

Diving air  
hose.

hose. Diving air hose received from store without this report shall not be placed in service until the report is received. If emergency requires the use of the hose before such report is received, it may be so used provided it is retested by the ship.

Subject to the foregoing as exceptions, diving hose in service should be hydrostatically tested when it is 2 years old and again when it is 2½ years old. The test pressures used should be 75 percent of those required for new hose. New hose, before delivery, is required to withstand a pressure of 250 pounds per square inch, held for 30 minutes without exposing imperfections, and a pressure of 1,000 pounds per square inch held momentarily without bursting. At this time, March 1943, the limitations on the length of service of diver's air hose are being investigated. It is considered that the period will be extended for use at depths less than 150 feet.

In making the tests, one length of hose, selected at random from each lot of hose on board of the same date of manufacture, as representative of the lot, should be subjected to the burst test. If the hose fails, the entire lot represented thereby should be replaced. Lengths of hose which have been subjected to bursting tests should not again be used for diving hose, but should be discarded and replaced. Replacement requirements for such lengths of hose should be anticipated as far in advance of the tests as possible and new hose requisitioned accordingly.

The ends of each length of diving air hose are capped with a rubber compound  $\frac{1}{8}$  inch thick to give the ends of the hose a smooth and watertight finish. It is sometimes the practice to cut defective sections out of a length of hose and recouple the good sections. This practice is not approved, except in an emergency, for the end of the cut section, not being rubber capped, permits the water to permeate along the braid and inner tube of the hose, forming bubbles which weaken the hose.

When coupling lengths of air hose together, a leather washer should always be placed in each female coupling and care taken to insure that the inside of new hose is free of soapstone. Air hose should not be coupled directly to the air supply but to the oil separators. Whenever special couplings such as double-male or double-female couplings are used, they should be placed in the line of air hose so that they will not be under water. Such couplings are intended for use in making surface connections.

If a long length of air hose has been in use, moisture is sure to have accumulated in it. The 50-foot sections should, therefore, be separated and drained before stowing.

The efficiency of the diving telephone equipment will be impaired by careless treatment. With a reasonable amount of attention the present standard diving telephones should give good service indefinitely.

Every part of the telephone outfit should be thoroughly cleaned and dried before stowing it away. The contacts of the plugs and the springs in the jack boxes should be kept clean and dry and, when not in use, covered with the protective caps and cap nuts which are provided. Oil should not be used on the contacts and springs, as oil tends to retain the salt contained in the water.

Diving  
telephones.

Care of jack  
plugs and  
springs of  
jack boxes.

Good contact must be obtained by keeping the connections bright and clean. Verdigris on the jacks and plugs must not be tolerated, as the current passing through them is so small that the least interference will stop its flow and put the telephone out of commission. Good contact must be attained by keeping the plugs and contact springs clean and bright, with the jack boxes correctly installed in the helmet gooseneck and cable connections so that they present proper alinement with the jack plugs. It is of no avail to use two hands on the telephone wrench to obtain contact by force. Such measures will probably bend the plugs and break the insulation bushings, resulting in leakage of water which eventually permeates the cable via its central hoisting member and conductors.

Under the conditions mentioned in the foregoing paragraph, it is sometimes found that shaking the jacks in their jack boxes results in renewed communication without the cause of the trouble being evidenced. However, it should be remembered that stoppage of telephone communication even temporarily is indicative of a short, a ground, or break in the circuits and every effort should be made to locate it.

**Amplifier.**

If the amplifier becomes inoperative, the power line should be checked to see if it is energized and of the right polarity; if of type A and a storage battery is used as a source of power, the battery voltage should be checked. If the power circuit is found to be satisfactory, remove the fuse posts on the amplifier with a screw driver and examine the fuses for burn-outs. Defective fuses should be replaced with good ones of 3 amperes rating.

If the foregoing procedure does not restore operation, the most likely source of trouble is failure of one or more of the vacuum tubes or if the amplifier is the batteryless type, failure of the power supply vibrator. To check or replace these tubes, the amplifier must be removed from its case by removing six screws located as follows: Two in the front of the amplifier near the top; one in the upper rear corner of each end; and one in each lower corner of the rear panel of the amplifier. This will enable the main amplifier panel, the cover and the rear panel to be withdrawn from the case as a unit.

Before removing the tubes it is necessary to loosen the locking clamps around the tube bases. Defective tubes and vibrators should be replaced with new ones. Only tubes of the type furnished with the amplifier should be used. The tubes are not interchangeable and replacement tubes should be installed in the sockets marked for the particular type of tube used. The amplifier will not operate satisfactorily if other types of tubes are used or the tubes interchanged.

If the foregoing check does not disclose the cause of failure, the trouble may be due to an open or short circuit in the amplifier connections. The circuit may be checked by reference to the respective wiring diagrams and list of parts as shown in chapter IV, plate 71. The wiring may be exposed by removing the hard-rubber key handles and one screw in each corner of the subpanel, thus permitting removal of the front panel.

The internal parts of the amplifiers should be kept dry at all

times. If water does accidentally get into the amplifier, the units should be carefully dried out before the power is connected.

If a telephone outfit is operating satisfactorily, it should not be disassembled. After diving, if an amplifier, helmet, transmitter-receiver, or tender's transmitter-receiver has become inoperative and the fault cannot be discovered and corrected by the procedure outlined in the foregoing, the defective element should be replaced and information as to the desired disposition of the defective parts obtained from the Bureau of Ships. Complete instructions for the care of the guided radio amplifier is contained in the instruction book accompanying each outfit.

Care should be exercised in unreeling the combination telephone and life-line cable when received on board. The coil of cable, as received, should be placed on a revolving platform or reel and uncoiled as the platform or reel revolves. The cable should not be pulled from the coil in the manner commonly used with rope, as this will twist the cable and cause kinks. Kinks especially should be avoided as they may damage the rubber cover or displace the conductor wires, thus causing early failure of the cable.

It is unnecessary to test the combination telephone and life-line cable for strength as the central core, which is the strength member, is of corrosion-resisting steel, has ample factor of safety, and is not susceptible to deterioration. Unfortunately, however, this is not the case as regards the conductor wires, which, being of copper, may in time stretch or break, thus impairing or destroying the circuit. When the breakage occurs, it is usually at the points of greater flexing of the cable. The points of greatest flexing are usually a few inches from either end of the cable due to the resultant bend in the cable at these points when the cable is under tension. Care should be taken to prevent the cable from getting a sharp nip or permanent bend at these points. Experience will facilitate the locating of such breaks and a study of the drawings showing the construction of the jack plugs will enable the jack plug to be assembled and reassembled when removing defective sections of the cable.

Continuity of circuit or grounds may be determined by test with a megger, a test lamp, or a magneto, following the same procedure as for determining an open or ground in any other circuit. In testing the cables remember that there is a complete electrical circuit from the metal sleeve of one telephone plug to the other plug. If through any cause an open or short develops in the cable, causing failure of the communication circuits, the jack plug at the damaged end of the cable should be removed, the faulty section of the cable cut off, and the jack plug replaced. Removal of the jack plug involves the following operations, the parts referred to being shown on plates 71-D and 71-C.

- (a) Unscrew the packing nut (pt. 14) at rear of plug housing (pt. 12).
- (b) Remove packing (pt. 13).
- (c) Remove lock nut (pt. 10) at front of plug housing with spanner wrench supplied.
- (d) Heat plug housing to soften the sealing compound.
- (e) Slide plug housing back on cable away from plug (pt. 4).

Combination  
telephone and  
life-line cable.

(f) Loosen connections to plug terminals and remove plug (pt. 4).

(g) Melt solder which secures stainless-steel core in the anchor plug (pt. 9) and remove the wood screw wedge (pt. 8) and anchor plug.

The cable may now be cut back until from the appearance of the butt end it is evident that all the damaged cable has been removed, and until the communication lines test through.

To reassemble the jack plug the procedure is as follows:

(a) Slide gland nut and jack plug housing onto cable.

(b) Remove the two outer rubber coverings for a distance of about 4 inches; untwist four telephone conductors and remove the rubber covering of the stainless-steel core also for about 4 inches.

(c) Separate the exposed strands of steel core and tin thoroughly.

(d) Slip anchor plug over the tinned strands and bring up as close as possible to rubber covering.

(e) Distribute strands around circumference of hole in plug and drive in wood screw wedge.

(f) Solder the steel core and wedge securely into anchor plug.

(g) Cut off loose ends of steel core even with anchor plug and smooth with file.

(h) Bare the ends of the telephone conductors and twist together into two pairs; red with green, and black with white. It is very important that this color coding be observed.

(i) Form an eye in the end of each pair and solder.

(j) Pull plug housing down over anchor plug as far as possible. Length of conductors should be such that eyes project about one-quarter inch out of plug housing.

(k) Several turns of suitable packing material should be inserted in the gland and the gland nut screwed in and pulled up tight.

(l) Place the thin leather washer over conductors and attach conductors to plug terminals making sure that red and green pair are connected to side terminal and black and white pair to center terminal.

(m) Pour melted sealing compound or beeswax into open end of housing to within  $\frac{1}{4}$  inch of plug seat.

(n) While the sealing compound is still soft, seat the jack plug in plug housing making certain that thin leather washer is properly situated on seat. Care must be taken to see that all space in the plug housing is filled with the sealing compound.

(o) Screw in locking nut and pull up tight to complete the assembly.

In case a bubble forms in the outer rubber covering of the cable due to leakage of compressed air from the diver's helmet, it is not necessary to cut off the injured section of cable unless the communication circuit is opened. The correct procedure is to puncture the bubble and wrap the puncture with several layers of rubber tape using plenty of rubber cement between layers. The rubber tape should be covered with one layer of friction tape and the whole patch then thoroughly shellacked. Before returning

the cable to service after a repair, it is essential that the cable jack plug be opened and inspected for leaks in the sealing compound. If any are found, the plug should be resealed. A similar inspection should be made of the telephone gooseneck fitting on the helmet, and the necessary repairs made.

The receiver, transmitter, or loud speaker units of the standard diving telephones are exceptionally rugged and unsusceptible to trouble usually experienced with ordinary telephones from the effect of moisture. Ordinarily, no serious damage is caused by short submersions but continued submersion or continuous exposure to moisture will result in corrosion of the metal parts and the grounding or short circuiting of the coils. If any of the units should be accidentally submerged in salt water, they should be washed out with fresh water and dried out by exposure to heat. Care should be taken, however, that the applied heat is not sufficient to burn the insulation of the wire. If any of the units become inoperative due to collection of dirt, they should be carefully dismantled and cleaned. The diaphragms and pole pieces especially should be kept free from dirt and sediment. After use the units should be wiped dry with a clean rag to remove all moisture before storing.

The packing of the diver's air control valve should be carefully adjusted so that the valve works stiffly enough to prevent its being closed or opened accidentally but sufficiently free to be readily manipulated by the diver even though wearing the two-finger rubber diving glove.

The foregoing instructions for the care of No. 1 diving outfits, are also applicable to the helmets, lead weights, diving air hose, and hand-operated air pump comprising shallow-water diving outfits. Helmets should be frequently examined to insure that the windows are intact and that the sealing strip and packing around their edges are in place, in good condition, and waertight. In these outfits the only exhaust which the helmet has is the bottom of the helmet. Consequently care should be taken to insure that there are no air leaks in the portion of the helmet above the air inlet connection. Leakage of air above the air-inlet connection will require an air supply of greater pressure than is ordinarily necessary to keep down the water level in the helmet. If the rate of leakage above the water inlet is greater than the rate of flow and pressure capacity of the pump, the water level in the helmet cannot be kept down below the mouth and nose of the diver.

The air pump of the shallow-water diving outfit contains two single-acting cylinders  $3\frac{3}{8}$ -inch bore by 4-inch stroke with a total capacity of about 72 cubic inches. The use of shallow-water diving outfits is permitted down to depths of 36 feet. The efficiency of the pumps for delivering air at the pressure equivalent to this depth with a reasonable factor of safety should be frequently checked.

Diving gear shall not be disposed of by ships or by navy yards and stations except the navy yards, Mare Island and New York. Diving gear which is considered no longer reliable or serviceable shall be surveyed and turned in by ships to the nearest navy yard for shipment to either the Mare Island Navy Yard or the Navy

Helmet and tenders, transmitter and receiver; care of.

Diver's air control valve.

Shallow-water diving outfits.

Survey of diving gear.

Yard, Brooklyn, N. Y., for survey and final disposition. When received by these yards, such gear as can be economically repaired shall be put in suitable condition for reissue and turned in to store. Gear beyond economical repair shall be surveyed for sale.

In disposing of diving gear by sale or otherwise, the yards authorized to do so should insure that the gear, especially the metal parts such as helmets, diving pumps, test tanks, etc., cannot be put in serviceable condition at a reasonable cost. For instance, helmets may contain minor defects such as dents, a missing faceplate, or a damaged gooseneck, etc., which, in the aggregate, would appear sufficiently detrimental to further use as to warrant survey. However, dents in the helmet (unless the metal is cracked) do not jeopardize the diver and they can readily be pressed out to make a more presentable helmet. Faceplates are easily renewed and other individual fittings can be reinstalled at small cost. A diving pump in its entirety is costly. Its fixed and moving metal parts are standard. If not available in store, they are readily obtainable from the manufacturer of the pump.

The parts comprising diving outfits are title B material. The allowance list of vessels list the number of complete outfits the respective vessels are entitled to. Owing to the large number of parts which comprise a standard diving outfit, the individual parts are not listed in the allowance list. However, vessels are entitled to obtain such replacement parts for these outfits as may be necessary to maintain the outfits in suitable condition at all times, on "not in excess" requisitions submitted to the nearest yard or station. If the yard or station to which such requisitions are submitted has not the requested equipment available, it shall be obtained from the Mare Island or New York Yard. Cost of diving outfits and replacement parts, when obtained by ships in commission, will ordinarily be charged to ship's regular construction and repair allotments.

In requisitioning diving gear, requisitions should contain notations as to the name-plate data, piece numbers or standard stock numbers (if the particular part requested is listed in the Standard Stock Catalog) to enable supply officers to identify the requested equipment properly.

For the care, survey, and requisitioning of special diving equipment not forming a part of standard diving outfits but which is furnished vessels of certain categories, attention is invited to chapter XIX.

Requisitions for diving gear.

Care of special equipment used by divers in standard outfits.

NOTES ON PATCHING AND REPAIRING DIVING DRESSES AND ATTACHING CUFFS AND GLOVES.

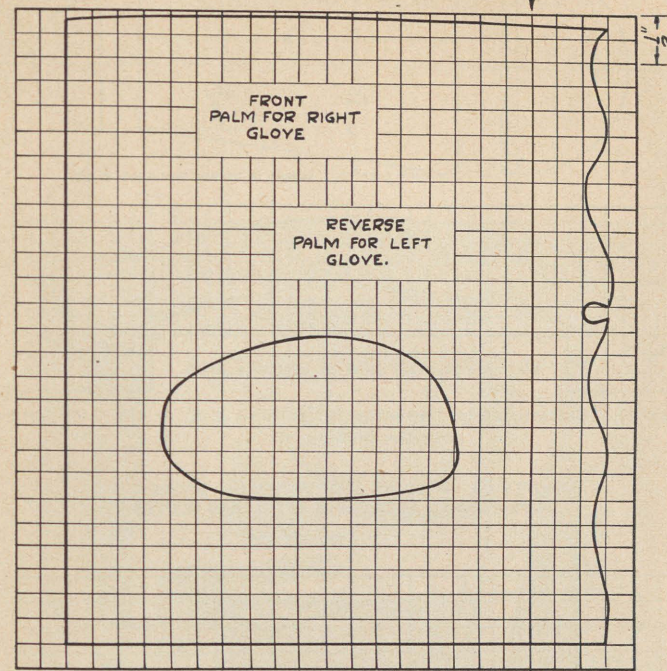

GLOVE PALM SECTION I.  
SECOND FORM OF GLOVES WITH HAND SLIGHTLY CUPPED  
TO SCALE  
PLATE 78.—Pattern, glove patching—Glove palm section I.

NOTES ON PATCHING AND REPAIRING DIVING DRESSES AND ATTACHING CUFFS AND GLOVES.

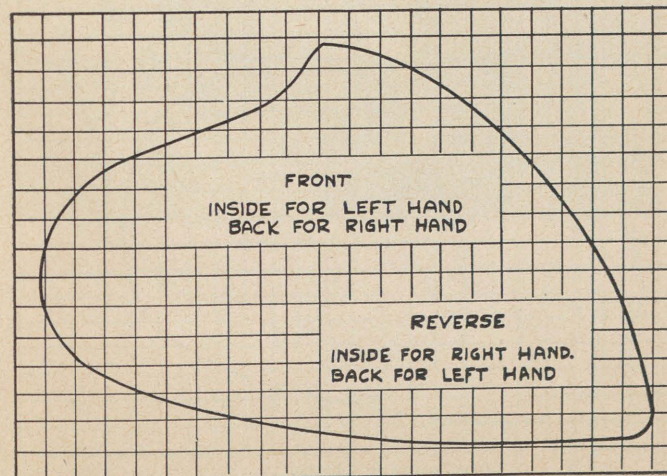

PATCH FOR GLOVE THUMB.  
TO SCALE

PLATE 79.—Pattern glove patching—Patch for glove thumb.

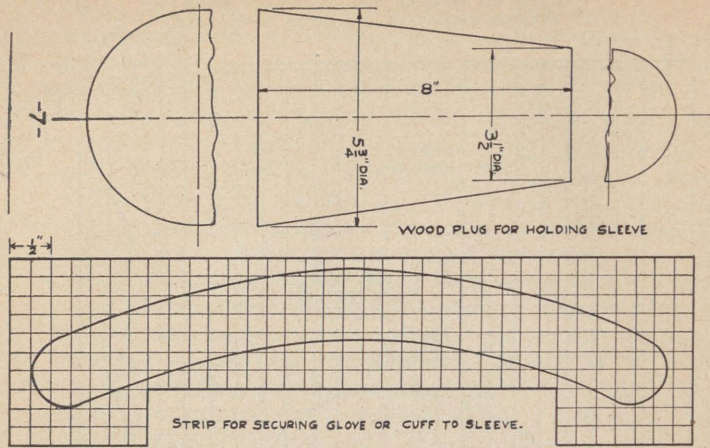

PLATE 80.—Pattern, strip for securing glove or cuff to sleeve and wood plug for holding sleeve.

NOTES ON PATCHING AND REPAIRING DIVING DRESSES AND ATTACHING CUFFS AND GLOVES.

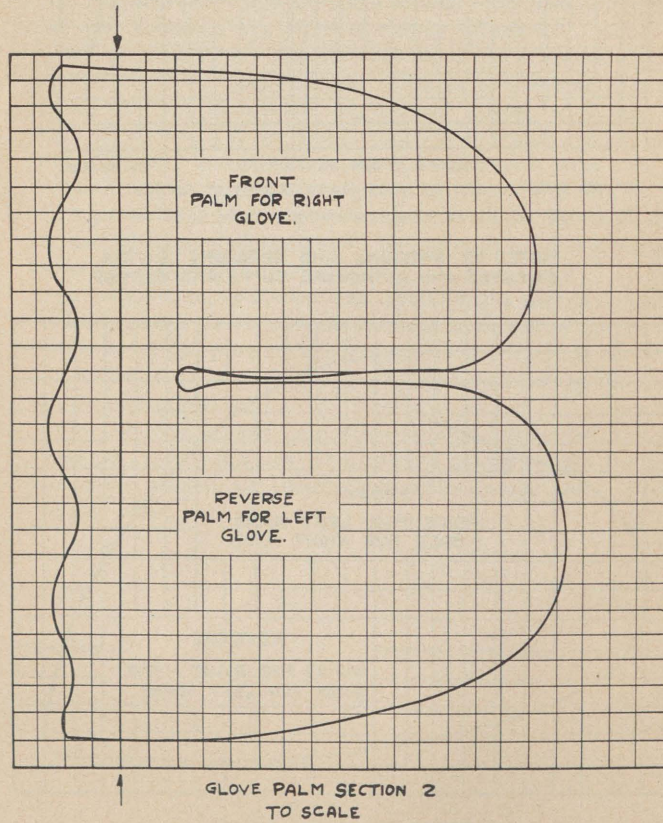

PLATE 81-A.—Gasoline-driven air compressor.

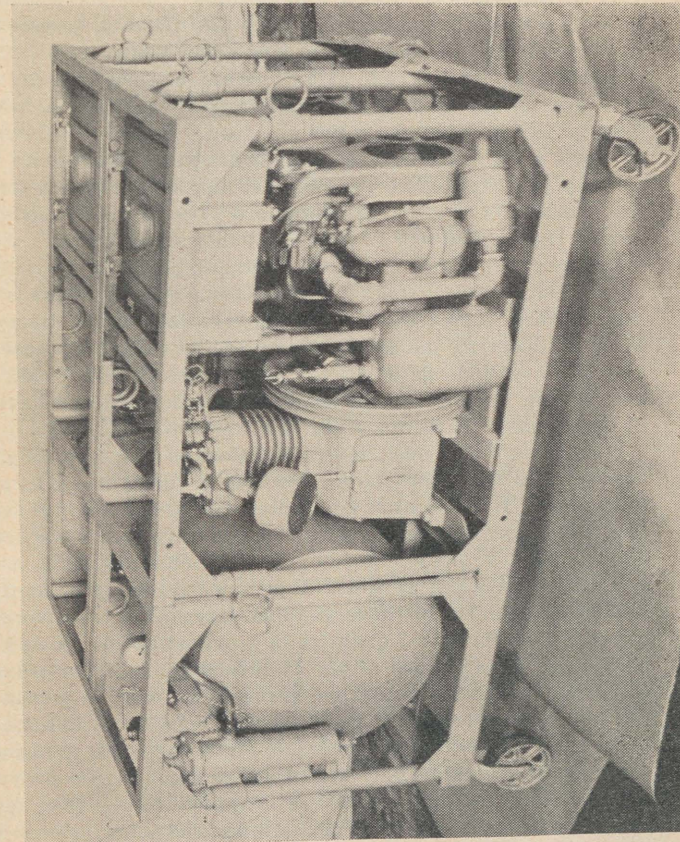

PLATE 81A.—Gasoline-driven air compressor.

## CHAPTER VII

### PHYSICS OF DIVING

1. In the study of diving and its effect upon the human body, it is important to consider some of the physical properties and laws governing the behavior of gases and water.

Boyle's law.

Boyle's law states that at a constant temperature the volume of a gas varies inversely as the pressure (absolute), while the density varies directly as the pressure. That is, an increase of pressure on a gas decreases its volume and increases its density directly proportional to the pressure applied, and vice versa. If the pressure is doubled, the volume will be decreased one-half; if tripled the volume will be decreased to one-third, etc.

Charles' law.

Charles' law states that at a constant pressure, the volume of a gas varies directly as the absolute temperature. That is, as the temperature increases, the volume increases and vice versa. When considering the centigrade scale, the volume of a gas varies  $\frac{1}{273}$  of its volume at 0° C. for every variation of 1° C. When considering the Fahrenheit scale the volume of a gas varies  $\frac{1}{491}$  of its volume at 0° F. for every variation of 1° F.

Oxygen.

Oxygen is a colorless, tasteless, odorless gas occurring in the free state in the atmosphere, of which it forms about 21 percent by volume. It is essential in maintenance of life. At atmospheric pressure, approximately one-fifth of the oxygen in each breath is absorbed by the body. More oxygen is necessary when a person is active than when at rest. A person exercising violently may require as high as 10 times as much oxygen as when completely at rest. The increased quantity is provided by deeper and faster breathing. The tissues of the body absorb a higher percentage of oxygen which is circulating in the blood when a person is exercising. More oxygen is required when the large muscles of the body, those of the legs for example, are doing work, than required when smaller muscles only are in active use. A person at rest at atmospheric pressure (sea level) is unable to absorb a sufficient amount of oxygen when the percentage falls below 13 percent, and unconsciousness usually occurs at 9 or 10 percent or at higher percentages—depending on the activity of the person. Oxygen deficiency usually is unaccompanied by warning symptoms. Its lack deadens the faculties, and a person not infrequently becomes unconscious without realizing anything is wrong. It must be remembered that it is the partial pressure of oxygen in the atmosphere that sustains life—that is, air, being composed of about 21 percent oxygen, exerts one-fifth of an atmosphere oxygen pressure at sea level. At 10 atmospheres pressure, equivalent to a depth of approximately 300 feet, the oxygen in the air supplied the diver being one-fifth would exert two atmospheres of oxygen

pressure or 200 percent. Likewise above sea level, the oxygen pressure in the air is reduced, the reduction being in ratio with the altitude. In other words, under excess pressures there is actually more oxygen in every cubic foot of air than there is in the air at sea level. Conversely, there is less oxygen in every cubic foot of air in the atmosphere above sea level. Obviously, therefore, a human being could not survive at high altitudes with as low a percentage of oxygen as at sea level. On the other hand, less percentages than those mentioned would be adequate below sea level.

Nitrogen is a noninflammable, colorless, gaseous, nonmetallic element, tasteless and odorless. While it forms about 80 percent of the atmosphere, in its free state, it will not support life. Hydrogen in its pure state, is a colorless, tasteless, odorless gas. It is the lightest known substance, being  $\frac{2}{29}$  the weight of air and about  $\frac{1}{11000}$  the weight of water. It is inflammable and explosive. These two gases as occurring in the atmosphere have no effect on the human body other than to dilute the oxygen as well as carbon dioxide and any other gases that may be present.

Nitrogen and hydrogen.

Carbon dioxide, sometimes called "carbonic-acid gas" consists of one part of carbon chemically combined with two parts of oxygen to form an odorless, colorless, transparent gas with a slightly acid taste. It can be reduced to solid state by intense cold and to liquid by pressure. Being much heavier than air, inert and dielectric, it is an efficient extinguisher of oil and gasoline fires, the gas blanketing the flame and cutting off contact with air, hence excluding the oxygen essential to combustion. It is usually liberated in nature by combustion (including slow decomposition of vegetable and animal matter) and by the breathing of animals. Oxygen taken into the lungs combines in the body with carbon, which is derived from food, and this chemical combination generates the heat which maintains body temperature. The resultant carbon dioxide is given off through the lungs and passes out with the breath.

Carbon dioxide.

Carbon dioxide, when breathed in high concentrations, is asphyxiating. When air is breathed, as, for example, in a confined space which is being inadequately ventilated, the carbon dioxide exhaled by the diver gradually builds up in the space, causing headache and other symptoms. When the proportion of carbon dioxide rises to approximately 5 percent and the air in such space is at atmospheric pressure, a person experiences distinct panting. With 8 percent the difficulty in breathing becomes distressing. Unconsciousness usually occurs when the percentages reach 10 percent. The increase in the depth and rapidity of breathing is caused by the increased amount of carbon dioxide accumulating in the blood and acting upon the respiratory center in the brain. It is by this means that the body secures the increased amount of oxygen needed and eliminates the excess of carbon dioxide. The need for oxygen does not directly affect the breathing. It is the presence of too much carbon dioxide in the blood that causes the deeper breathing and finally panting as the percentage of carbon dioxide increases. A person thus has some warning when the proportion of carbon dioxide is gradually increasing, although de-

pendence for safety should not be placed upon this but proper measures taken to insure that detrimental concentrations do not build up in the spaces which are being breathed in or from.

The foregoing pertains to the effects of carbon dioxide on the respiratory system under atmospheric pressure. Its effects under excess pressure are discussed in chapter IX (Diver's air supply).

Water.

Water (pure) consists of two parts hydrogen and one part of oxygen. It is a colorless, tasteless, transparent liquid and is almost incompressible. At its maximum density (39° F.) it is a standard for measuring specific gravities of all liquids and solids, 1 cubic centimeter of pure distilled water at this temperature weighing 1 gram. Pure water freezes at 32° F. (0° C.) and boils at 212° F. (100° C.). Besides having other values, it is an important ingredient in the tissues of animals and plants, the human body containing about two-thirds its weight of water.

Air.

Normal air (the atmosphere we breathe) is a simple mixture (not a chemical combination) of the gases described above with traces of hydrogen and certain other rare gases. It is compressible. The proportions of the main constituents are approximately as follows:

	<i>Percent by volume</i>
Nitrogen (approximately)-----	.79
Oxygen (approximately)-----	20.96
Carbon dioxide (approximately)-----	.04

Expired air varies in composition with the depth of the expiration and with the composition of the air inspired. Under normal conditions expired air contains in volume percent:

	<i>Percent</i>
Nitrogen (approximately)-----	79
Oxygen (approximately)-----	16.02

That is, expired air loses about 4.94 volume percent of oxygen and gains 4.34 percent carbon dioxide. The difference in the oxygen absorbed and the carbon dioxide (CO<sub>2</sub>) excreted is explained by the fact that in the physiological process of the body some of the oxygen is absorbed by the body, not only to oxidize carbon but also to combine with some of the hydrogen of the food and is consequently secreted as water.

Atmospheric pressure.

Atmospheric pressure is the pressure exerted by the weight of the atmosphere and is equal, at sea level, to 14.7 pounds per square inch. A column of mercury 30 inches high, a column of sea water 33 feet high, or a column of fresh water 34 feet high, each, also exert a pressure of 14.7 pounds per square inch, or 1 atmosphere, pressure at the bottom of their respective columns.

The term "atmospheres" as used herein means atmospheres of pressure and is the number of times 14.7 pounds per square inch is contained in the total pounds pressure per square inch involved. Thus 29.4 pounds pressure per square inch will equal (29.4÷14.7) 2 atmospheres pressure; 44.1 pounds pressure per square inch will equal 3 atmospheres, etc. To convert atmospheres pressure into pounds pressure per square inch, multiply the number of atmospheres pressure by the constant 14.7.

Absolute pressure is the pressure above a perfect vacuum. It is the gage pressure plus atmospheric pressure and is equal to 14.7 pounds plus excess pressure. Thus a diver working at a depth of 33 feet under water, the equivalent pressure of one atmosphere, would be exposed to an absolute pressure of 29.4 pounds per square inch.

Absolute pressure.

The gages used in diving do not record atmospheric pressure, but do record the pressure above atmospheric pressure. They also indicate the corresponding depth of water in feet. If a length of air hose be attached to a diving pump, the free end of the hose lowered under water and the pump operated, the gage on the pump will indicate the pressure of water and depth of water at the point to which the end of the hose has been submerged. Hence, this procedure provides an accurate means of determining depth and pressure of water or, if the depth is known, a convenient method for checking the accuracy of the gage.

Gage pressure.

It is obvious that if a tank be filled with water, the bottom of the tank has to support the whole weight of water, but the top has no weight of water to support. The pressure, therefore, on the bottom will be greater than the pressure on the top by an amount equal to the weight of the water in the tank. It is also obvious that the higher the sides of the tank are raised, still keeping it filled, the greater the weight or pressure becomes on the bottom. If the sides of the tank are extended to 33 feet and the tank filled with sea water, the pressure on the bottom due to the weight of water would be equal to that of the atmosphere, or 14.7 pounds per square inch; however, as the atmosphere is also pressing down on top of the column of water, the absolute pressure on the bottom will be 14.7 pounds due to weight of water, plus 14.7 pounds due to the atmosphere, or a total of 29.4 pounds per square inch absolute pressure. Every foot in height of sea water produces an excess pressure of 0.445 (or  $\frac{1}{33} \times 14.7$ ) pounds or a little under one-half pound per square inch. The same holds true when considering the pressure on a body immersed in water. Any such body may be looked on as having the column of water between it and the surface pressing down all round it. This pressure is transmitted to it in the form of a squeeze. If the body has appreciable length, such as a diver standing upright, there is less pressure upon the top of the body than at its bottom. Therefore, in the case of the diver, there is less pressure on his helmet than on his shoes. If the diver is 6 feet tall, there will be about 3 pounds per square inch less pressure on his helmet than on his shoes, whatever the depth of water he may happen to be in.

Water pressure.

A body submerged in a liquid is buoyed upward by a vertical force equal to the weight of liquid that the body displaces. The volume of the liquid displaced equals the volume of the body, and the upward pressure equals 62.5 pounds in fresh water, or 64 pounds in sea water, for each cubic foot of the volume of the submerged body. With the diving suit distended by air, the weight of the water displaced is greater than the combined weight of the suit, helmet, and diver. As a result, the dress, helmet, and diver are of positive buoyancy and the diver is unable to descend.

Buoyancy.

To overcome his positive buoyancy, weights are attached to the diver's dress in the form of a weighted belt and weighted shoes, giving the diver negative buoyancy. Ordinarily, only sufficient weight is added to overcome the positive buoyancy with the diving dress moderately distended by air. Therefore, if the dress is overinflated when the diver is submerged, he acquires positive buoyancy. If this buoyancy is not reduced to the negative side, the diver is unable to remain on the bottom. In rising, the buoyancy will be increased, due to the diminished water pressure and the expansion of the air within the elastic dress, and his speed of ascent will be accelerated. Being carried to the surface in this manner is known as "blowing up."

If, through carelessness or culpable neglect, a diver should be permitted to fall an appreciable distance under water, there would be a sudden increase of water pressure, and, if there should fail to be a sudden increase of air pressure, the helmet escape valve would be seated, the air within the dress would be compressed and forced from it into the noncompressible helmet, the volume diminishing with the increased pressure (Boyle's law). If this volume of air does not fill the helmet and equal the pressure of water at the depth to which the diver's body has fallen, the excess pressure exerted on the diver's body will tend to drive it into the helmet. The result is most apt to be a serious injury or immediate death for the diver. Falls from shallow to deeper depths are the most serious, as the relative difference in pressures is greater. This may be explained by the following:

If a diver at the surface, in 14.7 pounds pressure to the square inch (absolute), should fall 33 feet under water, every square inch of his body would have an additional pressure of 14.7 pounds, or 29.4 pounds absolute pressure, suddenly applied to it, a proportion of 2 to 1 over the pressure in the helmet. As the average body has an area of about 2,000 square inches, the total force exerted on the diver's body and tending to drive him into the rigid helmet would be several tons. If, under the same conditions, the diver should have fallen from the surface to a depth of 66 feet under water, the increase in absolute pressure would have been trebled instead of merely doubled, so from the foregoing it is clear that a long fall from a shallow depth would result in a fatal squeeze for the diver. Falls from moderate depths to deeper depths under water are not apt to be as serious as falls from shallow depths. In a fall from the surface to 33 feet the relative difference in pressure is as 1 is to 2 (atmospheres) or doubled, while in a fall from 165 feet to 198 feet the relative difference in pressure on the body is increased only one-sixth. The effect of a fall under water is known as a "squeeze."

As air is compressed its temperature increases rapidly, but this can be disregarded, for radiation through air reservoirs, conduits, and the rapid cooling induced by its transit through the diving hose to the diver reduces the temperature to or below the temperature of the surrounding sea water. This fact sometimes necessitates special measures in cold weather diving, to prevent the clogging of the air line due to freezing of moisture in the diver's air hose. This is further discussed under Chapter IX, "Diver's air supply."

Temperature  
of diving air.

## CHAPTER VIII

### DIVING PLANNING AND ARRANGING

When diving is to be undertaken, the commanding officer of the vessel shall be informed. A general plan of procedure shall be decided upon and the necessary officers, including a medical officer, and sufficient men to handle any emergency shall be detailed and an effort made to conduct the operations with dispatch and efficiency. An officer qualified in deep-sea diving should be placed in charge of the diving operations and the divers. If such an officer or warrant officer is not available, an officer familiar with the principles of diving should be placed in charge. If the diving is to be done from a diving launch, a dinghy or other small boat, properly manned and equipped, should be assigned as tender to the diving launch, if in the opinion of the officer in charge it is required.

Divers' work is no exception to the general rule that a task is more efficiently performed when the work involved has been properly studied and planned and preliminary work done in advance. In diving operations the procedure which proves most effective is the one which provides for the maximum amount of work that can be done on the surface to be performed by the surface crew, with a commensurate minimum amount to be performed by the diver on the bottom. Accordingly, in planning the work the procedure decided upon should be that which not only reduces the diver's work to a minimum, but which limits his operations to tasks which can be performed within a reasonable period under the conditions involved.

The success of past Navy salvage operations was contributed to considerably by the manner in which operations were preliminarily planned and the various phases of the anticipated work laid out and definite task assigned to each diver or group of divers. This not only systematized the work but the benefits derived from the competitive spirit created by the procedure were reflected in the mental attitude of the divers upon completion of the task, even though the required dive was of less than standard duration for the depth.

With the foregoing as essential requisites, the satisfactory prosecution of underwater work may be contributed to by application of the following rules:

- (a) Work night and day, while weather permits, provided sufficient divers are available.
- (b) Use good judgment, based upon consideration of the advice and commands of the diving supervisors, checked constantly with the work being performed, in determining the amount and kind of work for each task, and in picking the divers for the tasks.

(c) Prepare and assign the tasks and give the divers instructions well in advance. This enables the diver to think over the task and as a result he may offer suggestions or ask questions which may lead to a better accomplishment of the task.

(d) A diver may often, unintentionally, overestimate his ability to accomplish underwater work. His suggestions should be given thorough consideration, but tempered by the judgment of those in charge.

(e) Each diver of a group, in addition to his own specific instructions, should be given, at least, a general idea of what tasks the other divers of the group are to perform.

(f) Final instructions must be given to each diver, and to the group, *by one person only* if confusion and delay are to be avoided.

(g) If, as frequently occurs, the diver forgets part of his instructions, he must immediately ask advice from the diving supervisor; hence the diving supervisor must, during diving operations, be immediately available.

(h) When a diver is on the bottom, it is inadvisable to alter the prearranged task; consequently, should a change in procedure be deemed necessary, it is better to instruct and send down a new diver to replace him.

(i) Care should be exercised in evaluating the information obtained during an observation dive because the opportunity for observing conditions below the surface is limited. Therefore, it is well to base any plan of salvage operations upon the combined reports of several divers. In addition to the verbal reports, it is of value to have underwater sketches of the damage, made on a slate and whenever possible, actual measurements should be made.

(j) Several lines of procedure should be planned so that if one method fails in practice, alternative methods will be available.

Rescue and ship salvage operations can be performed only with proper type vessels properly equipped with necessary gear and a crew of efficient, qualified divers. The Navy vessels which are used for this purpose are converted mine sweepers, which, in addition to standard diving outfits, are provided with special diving and ship salvage gear described in chapter XIX. Work of this nature requires the mooring of the vessel over or approximately over the submerged wreck and safe diving operations depend upon the security of the moorings. The gear furnished is adequate for mooring these vessels under the normal conditions of weather and depth that permit diving. The mooring gear should be given a minute inspection before mooring and when divers are down a continuous watch should be placed to insure against any shifting of the moorings or veering of the vessel that would endanger the diver. Diving lines should have sufficient slack to guard against this contingency. In sudden squalls, heavy seas, tide, or any other condition which, in the opinion of the commanding officer, jeopardizes the security of the moorings, the divers should be brought up and diving discontinued until more favorable conditions obtain.

Experience has indicated that with the present limitations in the art of diving, the number of divers that can be submerged

Moorings and diving lines.

Group relay diving.

simultaneously and perform effective salvage or rescue work on submerged wrecks is limited. In past submarine salvage operations, it has been the practice to work the divers in relays of two or three, and where conditions permit, it is desirable to adhere to this practice in any future salvage or rescue operations. However, it must be remembered that the greater the number of divers submerged, the greater the possibility of entanglement of the larger number of lines involved, and that for continuous diving in deep depths, this number would be multiplied by the lines of divers decompressing in the water simultaneously with those working on the bottom. Accordingly, the number of divers which can safely be submerged simultaneously will depend upon depth of water and nature of the bottom, the ship's facilities for handling the divers over each side, and the practicability of this procedure under attendant conditions, the freedom of the wreck from debris, and the conditions of the weather and sea. Based on a consideration of these factors, the number of divers that may be submerged simultaneously shall be governed by the discretion of the officer in charge of the operations.

In planning the work of divers, arrangements should be such as to preclude any necessity for their stay on the bottom in excess of the optimum time of exposure listed in table 1, chapter XIV.

Usually there is much less tide on the bottom than at the surface. Consequently, although the surface tide may seem strong, it may be advantageous to attempt diving, provided the surface tide is not such as to endanger the moorings. If the velocity of the current is over  $1\frac{1}{2}$  knots, the diver should wear additional weights. A descending line must always be used for descents and ascents.

While all diving involved in submarine salvage work is now conducted from ships especially equipped with compressed-air systems, routine diving operations such as salvage of lost ground tackle, examination of ships' bottoms, lost torpedoes, airplane salvage, etc., engaged in by other classes of ships in general are performed with air derived from manually-operated air pumps.

In rigging a diving air pump preparatory to diving operations, the nuts on the pump wheels and handles should be tightened by a wrench, and the pump tried to ascertain if it is working properly. Before starting to use the pump, see that each and every bearing is properly oiled. Water must be occasionally supplied to the cistern to keep the cylinders cool during operation. The diver's air hose should not be connected directly to the delivery nozzle of a diving pump, but instead to an oil separator.

When air is required for two divers, the pump's control lever should be placed to the left-hand side, marked "One cylinder," but when only one diver is to be supplied with air in deep water, the lever should be placed on the right-hand side marked "Two cylinders." It is advisable to have two pumps rigged and ready for use, if they are available.

The following accidents have happened while pumping air to divers:

(a) Pump capsized during a sudden squall; not secured properly.

Duration of dives.

Diving in tideway.

Diving with air from diving pump.

- (b) Pump handle securing nut worked loose and fell off.
- (c) Pump wheel securing nut worked off.
- (d) Piston backed off end of rod far enough to stop pump.
- (e) Pump cover slammed shut, causing oil cam and wrench which had been left inside the cover to fall into the pump and jam it.
- (f) Due to faulty gasket, water leaked out of the water cistern, causing the air to become hot and the diver forced to ascend; diver much distressed.
- (g) Transfer valve assembled wrong thereby causing distress to diver.
- (h) Valve broken in pump thereby causing increased loss of efficiency.
- (i) Wrong kind of oil used in pump's cylinders, thereby causing the diver to become nauseated.
- (j) Excessive piston leakage; divers brought to the surface unconscious.
- (k) Air reservoir cover gaskets defective, thereby causing loss of air and distress to the diver.

Use of manually operated air pumps in motor launches.

Whenever practicable, diving from manually-operated air pumps should be carried out from a motor launch. All motor launches in service are fitted with pad eyes (see pl. 82) for hooking in the hook ends of the turnbuckles for securing the diving air pump in operating position. If there are any cases in which such pad eyes are not fitted, they should be installed by the ship's force. The pad eyes must be placed forward in the boat so that the diving air pump may be secured so as to leave room for the pumping crew to operate the pump. The pumping crew then will not be in the way of the diver and the men attending him, nor interfere with their view of the pump gages, which should face aft. The pump must always be rigidly secured in place to prevent it from capsizing in case of a sudden wash or unexpected change in weather.

Use of gasoline driven air compressor from motor launches.

When using the new gasoline driven air compressor in motor launches, care should be taken that the compressor is well secured and that it is in good mechanical condition. The instructions contained in each outfit should be closely adhered to at all times. The depths to which diving is limited is given in each instruction book and should not be exceeded. These compressors have been thoroughly tested and will be found to meet the requirements of a diver's air supply if used as intended, which is as a substitute for the hand pump.

Use of compressed air in motor launches.

The employment of compressed air for diving has numerous advantages over the air supplied from manually-operated air pumps, as it affords a constant and uniform supply at all depths. The diver's work is made much easier and safer as he has instant control of his air supply. The labor of pumping is dispensed with and fewer men are required in the diving party, thus providing more room in the diving launch. Consequently, when a motor launch is available and can be devoted to diving purposes without interfering with its use as a general working boat, the necessary fittings, chocks, etc., should be fitted so that four torpedo air flasks may be neatly stowed under the thwarts for use

in lieu of the diving pump for supplying air to divers. The necessary high-pressure copper air tubing, connections, etc., must be fitted for connecting the torpedo air flasks to the testing tank in accordance with the arrangement shown on plate 85.

When torpedo air flasks are used, the exercise heads, afterbodies, and delicate parts of the torpedo mechanism should be removed from the flasks; outlets not needed should be blanked off, etc.

Prior to being used for diving, the air flasks should be thoroughly cleaned inside of any rust, dirt, oil, or grease which would be apt to contaminate the air contained in them. All tanks supplied for this purpose shall be stamped "Not to be charged over — pounds" (usually 1,000 pounds). In recharging the tanks, the pressure should never exceed this stamped rated capacity.

When diving with compressed air from torpedo air flasks, plate 85, the torpedo stop valves on the flask from which air is to be used by the divers shall be opened and left open during the time the diver's helmet is being worn. The diver's air supply shall be drawn directly from the testing tank, in which the air shall be very carefully maintained at the pressure prescribed by the officer in charge.

The piping to the testing tank shall always be so arranged that, in the case of the failure of one valve the high-pressure air may be controlled by a duplicate valve. In no case shall a reducing or automatic valve of any kind be placed in the air line between the diver and the test tank.

In planning for the use of a diving launch, sufficient men should be detailed to manage the launch independent of the men required to man the diving pump (if used), or to operate the air system if from torpedo air flasks, and for attendants to the diver. The following equipment must be in the diving launch before it is permitted to leave the shore or immediate vicinity of the ship:

The required number of torpedo air flasks, fully charged, and all necessary connections and special tools. If a diving air pump is to be used, it must be complete, in working order, and properly secured.

Complete diving outfits for two divers.

Tool box containing air hose, wrench and washers, wing nuts, etc.

Spare washers for air hose.

Spare rubber wrist rings.

Descending line and distance line.

A length of rope for sending down to diver.

Diving ladder.

Diving Manual.

Decompression stage.

Decompression tables.

Slate with pencil attached.

Red diving flag on staff.

Lead line.

Stadimeter or sextant.

Boat's diving anchor gear with extra anchor for bow and stern.

Jackknives.

Manning and equipping the diving launch.

- 10-foot probe made of 1/4-inch pipe.
- Steel tape measure and 6-foot rule.
- Boat's compass.
- Hand flags for signaling.
- Boat box.
- Boat medical outfit.
- Binoculars.
- A watch for timing divers.
- Long heaving line.
- Several large shackles.
- A coil of small stuff (marline) for lashings.
- A luff tackle.
- Drinking water.
- Other special gear as necessary.
- Bucket of soapy water if dress without gloves is used.
- Blueprint or sketch of job.

Repairs to hulls.

In planning for emergency repairs to the hulls of vessels, the following items should be on hand: Velocity power tools, collision mats, patent leak stoppers, mattresses, canvas, swabs, cotton waste, caulking, wooden wedges, mild steel plate for small holes, hook-bolts, soft grommets made by tow and tallow kneaded together and parceled round with cloth, rubber gaskets, ample supply of planking for large holes, wire cable, bungs, wooden plugs for closing valve openings, and wire brushes and prickers for use in cleaning valve gratings.

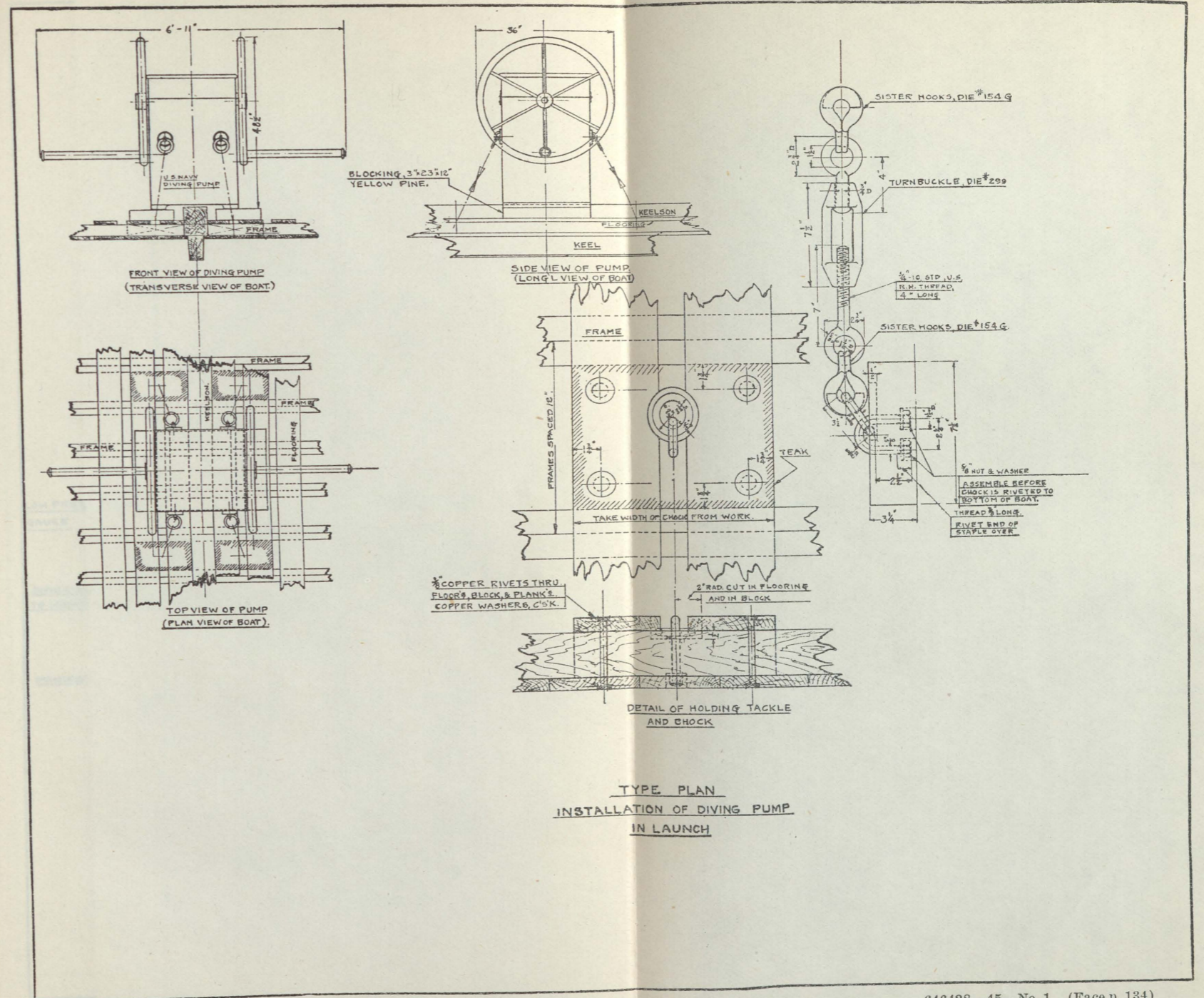

PLATE 83.—Type plan—Installation of diving pump in launch.

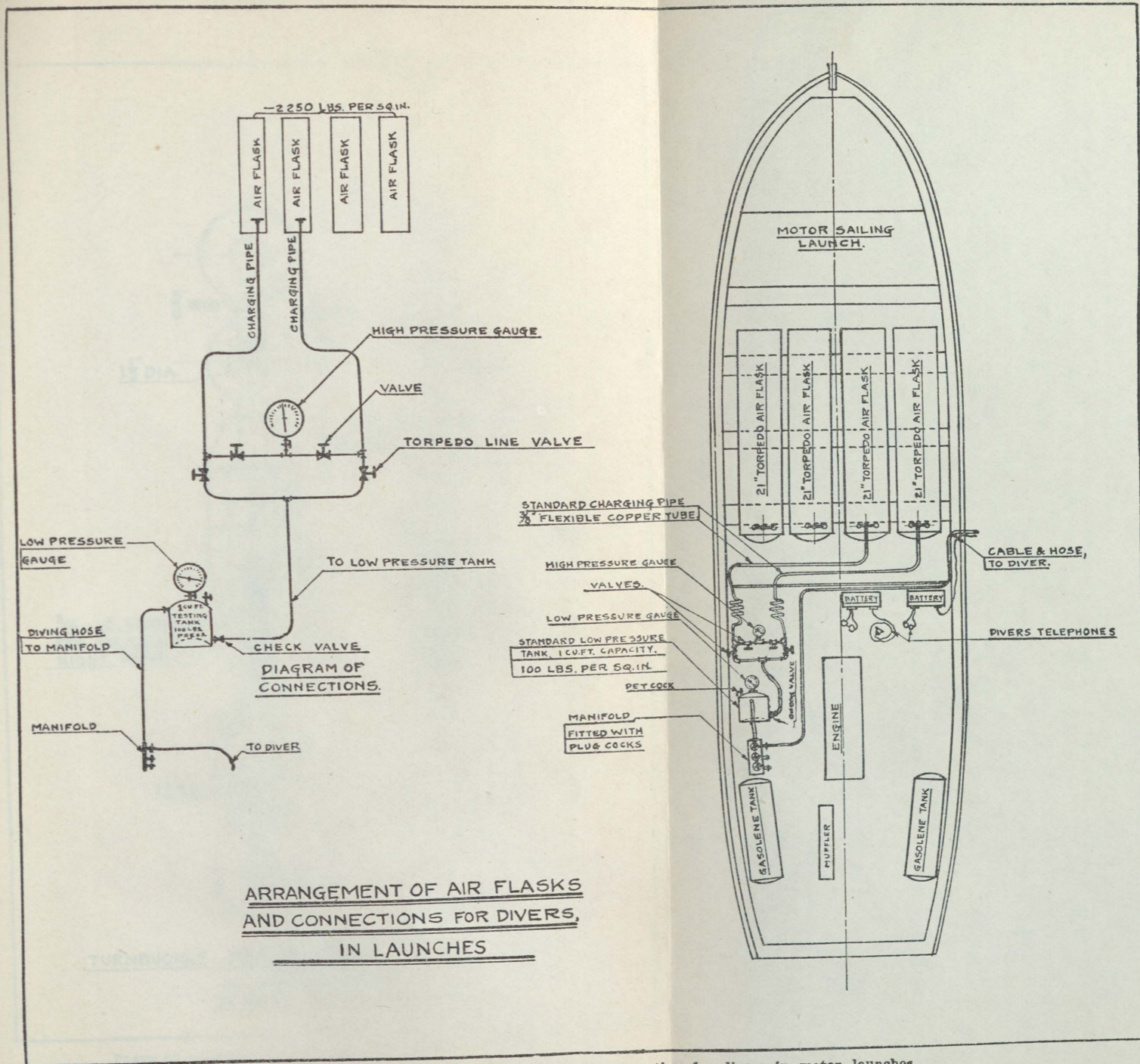

PLATE 85.—Arrangement of air flasks and connection for divers in motor launches. 646428—45—No. 2 (Face p. 134)



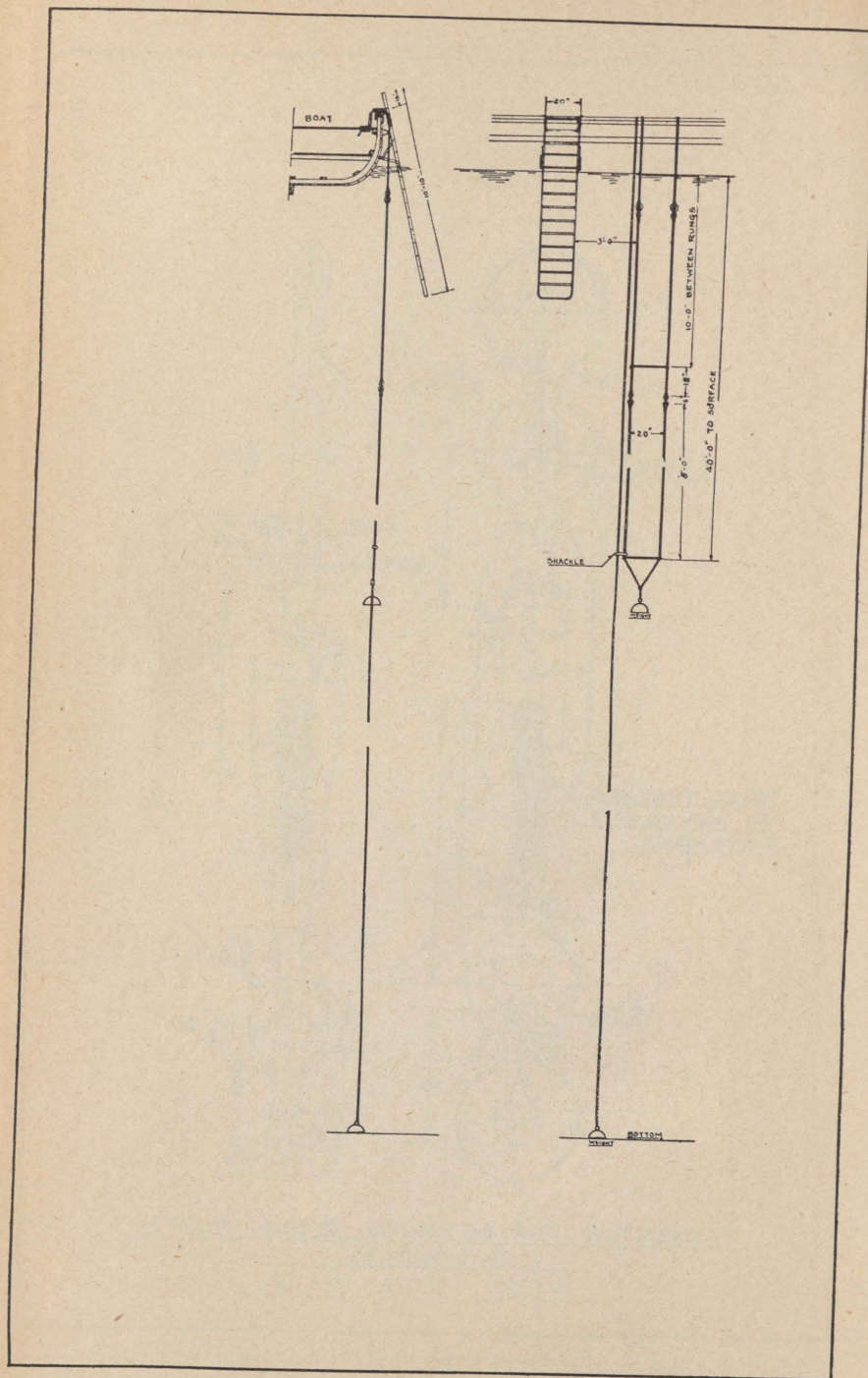

PLATE 84.—Arrangement of diving ladder, decompression stage, and descending line on diving launch.

## CHAPTER IX

### DIVER'S AIR SUPPLY (NORMAL AIR)

The average man at rest breathes about 0.25 cubic foot of air per minute. The breathing is so regulated as to keep the partial pressure of alveolar  $\text{CO}_2$  steady at about 5.25 percent of an atmosphere though the volume percent under conditions of varied barometric pressure differs widely; this means that at rest and at normal atmospheric pressure the alveolar  $\text{CO}_2$  is maintained at about 40 mm. mercury, since 40 is 5.25 percent of 760. If the alveolar  $\text{CO}_2$  pressure falls, breathing is diminished, and if it rises, the breathing is increased. Moderate work increases the  $\text{CO}_2$  secreted by the lungs three or four times and hard work six to eight times the normal resting amount, and therefore the air breathed is consequently increased. Hence, it is the partial pressure of the alveolar  $\text{CO}_2$  that regulates the breathing. **Breathing.**

When the inspired air at normal atmospheric pressure contains 3 percent by volume of  $\text{CO}_2$ , the breathing begins to be noticeably increased; 6 percent causes distress, and 10 percent or more unconsciousness. The physiological action of gases present in the air breathed depends on their partial pressure. Hence, the volume percent of  $\text{CO}_2$  in the inspired air that can be tolerated is inversely proportional to the absolute pressure. Thus, at a depth of 264 feet, or 9 atmospheres absolute, three-ninths of 1 percent, or 0.33 percent  $\text{CO}_2$  by volume, would have the same physiological effect as 3 percent  $\text{CO}_2$  would have at the surface.

The average adult man at rest produces about 0.014 cubic foot of  $\text{CO}_2$  per minute (measured at atmospheric pressure). The diver at rest produces about 0.019 cubic foot per minute and when performing moderately hard work, about 0.045 cubic foot of  $\text{CO}_2$  per minute (measured at atmospheric pressure). As the diver is constantly exhaling  $\text{CO}_2$  into the helmet, it is evident that unless the helmet is ventilated constantly with fresh air in sufficient quantity, he would soon suffer from the effects of an accumulation of  $\text{CO}_2$ . **Ventilation.**

Since 3 percent  $\text{CO}_2$  at atmospheric pressure is about the maximum that can be tolerated without distress, it is essential that the equivalent of this percentage under the partial pressures in the helmet should not be exceeded. To keep the  $\text{CO}_2$  content of the helmet within this maximum permissible percentage, a minimum air supply of 1.5 cubic feet per minute (measured at the absolute pressure to which the dive is made) is necessary. Since, according to Boyle's law, the volume of a gas is inversely proportional to the pressure, the air supply measured at the surface must be increased in proportion to the absolute pressure. Since each 33 feet of sea water exercises a pressure of 1 atmosphere,

the air supply measured at the surface must be increased one thirty-third for each foot dived. Using the reciprocal 0.0303, the minimum air supply for any depth may be calculated:  $S = 1.5(1 + F(0.0303))$ , in which S is the required air supply in cubic feet measured at the surface, and F is the number of feet the diver is below the surface. Better ventilation than this is imperative, however, and arrangements should be made for supplying three times this quantity of air per minute.

Exclusive of self-contained diving apparatus, there are the following four methods of ventilation of the diver's helmet:

1. Supplying air up to 2,500 pounds per square inch from high-pressure accumulators, i. e., torpedo air flasks or other accumulators.

2. Supplying air up to 400 pounds per square inch from low-pressure accumulators charged or charging them by power-driven compressors. Such low-pressure supply includes the battery gas-ejector system or low-pressure receivers. Submarine rescue vessels are equipped with this type air system and with a high-pressure stand-by system such as noted in subparagraph 1.

3. With air from hand-operated air pumps.

4. Portable gasoline driven air compressors.

#### Air-plants.

When diving operations are to be conducted from a vessel, using the vessel itself as a diving platform, the necessary air connections for the divers may be made directly to either the vessel's high- or low-pressure air installation. In any case, when diving is to be conducted in this manner, the diving hose shall be connected directly to the outlet nipple on the expansion tank (reservoir), and the inlet connection shall be made of piping. Only high-pressure piping shall be used when high-pressure air is to be utilized and, in every case, a suitable pressure-indicating gage shall be installed—temporarily if necessary—so that the pressure in the air-supply pipe line will be indicated to the diver's attendants. The actual air pressure in the diver's air hose, however, will be indicated by the low-pressure gage on the testing tank.

#### Torpedo air flasks.

When diving with compressed air from torpedo flasks (pl. 85), the torpedo stop valves on the flask, from which air is to be used, shall be opened and left open during the time the helmet is being worn by the diver. The diver's air supply shall be taken directly from the testing tank, and the pressure of the air therein shall be prescribed by the officer in charge. This same general procedure shall be followed when diving is undertaken with compressed air furnished from other air reservoirs. The piping to the testing tank shall always be arranged so that in case of failure of one valve, the high-pressure air may be controlled by a duplicate valve.

When diving operations are to be conducted from a vessel carrying torpedoes, a convenient air reservoir can be obtained by connecting three or more torpedo flasks to the regular torpedo charging line, and opening the stop valves on these flasks, thus permitting the air to back through the line. This arrangement provides an air reservoir equal to the capacity of the flasks so connected. Then the diving air line should be connected, in the most

convenient manner, to the charging line; care being taken to duplicate the previously mentioned double-valve controlling feature. Since these torpedo flasks may also be connected directly to the compressor, it is evident that the air pressure in the flasks may be raised and held to capacity by operating the compressor.

When diving at a depth over 120 feet from a small boat and using torpedo air flasks, a relief diving boat shall be equipped fully and kept ready for emergency use. Also, not more than two divers shall be permitted to dive from the same boat. When the diver's air is supplied from torpedo air flasks, at least three or more flasks must be connected, ready for use, one flask to be held in reserve. The pressure in the working flasks, as indicated on the high-pressure gage, shall not be permitted to fall below 220 pounds per square inch in excess of that at which the divers are working while on the bottom. If the gage pressure in the flasks approaches 220 pounds, the divers should be brought up. After they are clear of the bottom and safely on their way toward the surface, the reserve flask may be used. An exception to this rule will be permitted if there is available an additional, independent air supply which can be connected immediately to the diving air manifold.

The duration of air supply from an air flask may be calculated according to the following formula:

$$\frac{C(A - (15 + E + 1))}{4.5D(E + 1)} = \text{Number minutes}$$

C=Capacity of one air flask in cubic feet.

A=Atmospheres pressure of air in flask (pounds per square inch divided by 14.7).

E=Pressure in atmospheres to which dive is to be made (depth in feet divided by 33).

D=Number of divers.

In this formula, the "1" in the numerator is one air flask atmosphere which is allowed for charging the testing tank, air hose, and helmet. The "15" is the 15 atmospheres constituting the 220 pounds per square-inch pressure which has to be preserved in the flask as a minimum reserve. In the denominator, the 4.5 is the cubic feet of air required by each diver per minute measured at absolute pressure and the "1" is the 1 atmosphere of pressure which has to be added to the pressure at which the dive is made to obtain the absolute pressure.

*Example.*—One diver is to descend to a depth of 165 feet. How long will the air last if furnished from one 11-cubic-foot air flask charged to a pressure of 2,250 pounds per square inch?

$$C = 11 \qquad E = \frac{165}{33} \text{ or } 5$$

$$A = \frac{2250}{14.7} \text{ or } 153 \qquad D = 1$$

$$\text{Calculation: } \frac{11(153 - (15 + 5 + 1))}{4.5 \times 1 \times (5 + 1)} = 53 \text{ minutes}$$

Thus when using the maximum air supply from a small-size flask, one diver can descend to a depth of 165 feet and remain for 53 minutes, and still have sufficient air for proper decompression; hence with two such air flasks being used, one diver may remain

at this depth for 106 minutes, or two divers for 53 minutes. If larger or additional flasks are used, the diving time may be extended.

**High-pressure accumulators.**

By high-pressure accumulators, reference is made to the air accumulators of the torpedo installation aboard vessels equipped with torpedoes. When connections are made to accumulators, diving operations should be conducted directly from or in the immediate vicinity of the vessel carrying the accumulators, thus obviating the necessity for use of long lengths of air hose. If the accumulators are of sufficient capacity, diving may be undertaken from those already fully charged, but if they are not of sufficient capacity to meet the requirements of depth and duration of the dive without recharging, then the compressor shall be operated as necessary, and care taken that the water cooling system is in order and in operation—to insure cool air supply.

The capacity of the air compressor and the accumulators must be known and taken into consideration when calculating the air supply. For example: The capacity of a compressor is 15 cubic feet at 2,500 pounds pressure per square inch per hour or 0.25 of a cubic foot at 2,500 pounds pressure per square inch per minute. As 2,500 pounds per square inch would equal  $\frac{2500}{147}$  or 170 atmospheres, 0.25 cubic foot at 2,500 pounds pressure would equal  $170 \times 0.25$  or 42.5 cubic feet at atmospheric pressure. Therefore, since a diver must have an air supply of 4.5 cubic feet per minute at a pressure equal to the absolute pressure at which the dive is made, a dive by one diver to, say, 274 feet, or 8.3 atmospheres, excess pressure (9.3 atmospheres absolute) would require  $4.5 \times 9.3$  or 41.85 cubic feet of air per minute at atmospheric pressure. From this, it is evident that this power-driven compressor working at full capacity would just be able to furnish this supply of air. Under no circumstances, however, must divers be permitted to dive to the limit of their air supply, whatever the source utilized may be.

Also, sufficient air must be held in reserve to enable the dispatch of a relief diver. The capacity of the air accumulators aboard may be augmented by connecting them to the torpedo air flasks that have their stop valves open, and taking the air lead from this connection. When charging high-pressure accumulators, it must be remembered, the air is heated by the compressor's cylinders; hence castor oil should be used to prevent flashing in the cylinders and thus preventing CO and CO<sub>2</sub> production or if not available use Navy symbol 2190T or equal. For this and other reasons, as little oil as practicable should be used in the cylinders. Likewise, the air intakes of any compressors used for supplying diver's air must be located in atmosphere that is free from obnoxious or toxic fumes.

**Low-pressure accumulators.**

The supplying of air to divers from low-pressure accumulators is applicable to vessels equipped with a gas-ejector system, to submarine rescue vessels, to navy yards, etc. The arrangement is practically the same as for diving with air from high-pressure accumulators. The air pressure in the accumulators is maintained constant by large capacity low-pressure, steam or elec-

trically driven, automatically controlled air compressors. The capacity of these compressors is such that there is never a question of shortage of air supply. The maximum depth to which a diver or divers may descend will depend upon the pressure of the air supply and the amount of air that is required to pass through the diver's helmet, and since there is no accurate method of determining the latter when using this source of supply, the only means of knowing whether adequate ventilation exists is by the diver's own feeling of well-being.

When utilizing air from air accumulators or air flasks, the following conditions are essential:

(a) The temperature of air must be such as not to cause discomfort to the diver.

(b) The air in the accumulator must be free from noxious fumes and as near standard purity as possible, i. e., contain 0.04 percent CO<sub>2</sub> or less. In utilizing air from high-pressure accumulators it must be remembered that the air in the cylinders of the compressors is greatly heated in charging the accumulators, and oil with a high flash point must be used, castor oil if possible, so that no flashing in the cylinders will take place, producing CO and CO<sub>2</sub>. As little oil as practicable should be used in the cylinders of a diving pump.

(c) Thirty to fifty pounds pressure per square inch in the testing tank above water pressure (at the depth of dive) must be maintained to insure proper ventilation of the helmet.

(d) The reserve air supply must always be maintained in case of accident to compressors, etc., to insure a proper stage decompression for the diver.

In utilizing manually-operated diving air pumps to furnish air for divers, it is evident that the delivery of the amount of air required by a diver at various depths of submergence under water depends upon the capacities of the pumps, the number in use, and the rate of pumping.

As the capacity of the standard diving pump is small and as the rate of pumping may be varied only within small limits, which become less and less as the pressure increases, it is apparent that, with only one diving pump to furnish air, the depth to which a diver may descend and perform useful work is limited to comparatively shallow depths. If the pump so used is not efficient, the depth of dive will be further restricted.

When it is required to dive to a certain depth and it is not possible to furnish the requisite volume of air for that depth with a single diving pump, two or more pumps, if they are available, may be connected together and operated at the proper rate of speed.

When using manually-operated diving air pumps to furnish air for divers, the following conditions shall be observed:

(a) Arrangements shall be made to furnish at least the minimum allowable air supply (1.5 cubic feet per minute, measured at the absolute pressure to which the dive is to be made) to each diver, and if practicable, a reserve air supply. Only one pump is furnished with a diving outfit and if conditions are such as cannot be met with one pump, an additional pump or pumps as

**Precautions in supplying air from accumulators and air flasks.**

**Diving air pumps.**

**Precautions in using manually operated air pumps.**

required should be obtained from tenders or other accompanying vessels.

(b) Arrangements shall be made to insure the dispatch of a relief diver.

(c) More than one diver shall not be permitted to dive simultaneously from the same diving pump or group of pumps except under the following conditions:

(1) Where one diver is working on the bottom and an emergency occurs requiring descent of a relief diver, the relief diver may be supplied with air from the same pump or group of pumps, provided the pump reserve capacity is ample to fill the requirements of two divers at the depth of the dive.

(2) Where the efficiency of the pump or pumps is sufficiently high and the water sufficiently shallow and there is no danger of the divers becoming foul of obstructions on the bottom, two divers may dive simultaneously from the same pump or group of pumps, provided an adequate reserve supply of air is available for a relief diver.

(d) The rate of pumping shall be regular.

(e) If the air being supplied to a diver is uncomfortably warm, cold water shall be placed in the cisterns of diving air pumps, and kept cold by the addition of ice, if necessary.

(f) The directions for lubricating diving air pumps shall be carefully carried out.

Assuming a diving air pump to be 100 percent efficient at all pressures, the number of revolutions per minute the pump should be run to furnish the minimum allowable air supply to one diver (1.5 cubic feet of air per minute, measured at the absolute pressure to which the dive is made) may be determined as follows:  
When

D=Depth of sea water, in feet, to which dive is made.

N=Number of cubic inches of air pump will furnish per revolution measured at atmospheric pressure.

R=Number of revolutions required of pump per minute to furnish 1.5 cubic feet (2,592 cubic inches) of air per minute, measured at atmospheric pressure.

X=Number of revolutions required of pump per minute to furnish minimum allowable air supply. (1.5 cubic feet or 2,592 cubic inches per minute at D.)

$$R = \frac{2592}{N} \text{ and}$$

$$X = R(1 + D(0.0303)).$$

or the efficiency of any diving air pump is less than 100 percent and its actual percent efficiency, at the equivalent absolute pressure of the dive, D, is represented by a symbol, as E, then

$$X = \frac{100R(1 + D(0.0303))}{E}$$

The value of N, for the Navy standard Mark III diving pump when 100 percent efficient is 405 cubic inches. Therefore, R equals  $2.592 \div 405$  or 6.4 revolutions per minute.

The "constant" for any pump may be obtained by multiplying

R by the depth coefficient 0.0303. In the case of the Navy standard diving pump,  $6.4 \times 0.0303 = 0.194$  is the constant. Specifically, the number of revolutions required of the standard pump to furnish the minimum allowable air supply (1.5 cubic feet per minute) for one diver at any depth may be determined by the following formula:

$$X = \frac{100(D \times C) + R}{E} \text{ in which}$$

X=Number of revolutions required.

E=Actual percent of efficiency of pump at the equivalent pressure to which the dive is made as determined by pumping into the testing tank.

D=Depth in feet.

C=Pump's constant (0.194).

R=Number of revolutions required of pump per minute to furnish 1.5 cubic feet or 2,592 cubic inches of air per minute, measured at atmospheric pressure.

*Example.*—Diving air pump, Mark III is 80 percent efficient; depth of sea water is 66 feet. At how many revolutions per minute should the pump be run to furnish the minimum allowable air supply (1.5 cubic feet per minute) to a diver working at that depth?

Solution:

$$X = \frac{100(66 \times 0.194) + 6.4}{80} \\ = 24 \text{ revolutions per minute}$$

The maximum rate of pumping that it is possible to maintain by a pumping crew over a practical period of time is approximately 30 revolutions per minute. With the pump 80 percent efficient, this rate would barely supply the minimum amount of air required at a depth of 90 feet. If the number of revolutions required are in excess of the number that it is possible to maintain, the work should be divided between two or more pumps. For example, using the above formula to determine the number of revolutions required to furnish the minimum amount of air necessary for one diver working at a depth of, say, 168 feet, it will be found that with a pump 80 percent efficient, 48.7 revolutions per minute are necessary—a rate which is beyond the capacity of a pump crew to maintain. Hence two standard pumps, with efficiencies of not less than 80 percent each, operated at approximately 24.5 revolutions per minute each, would be required.

Limiting depths for diving with gasoline driven air compressors cannot be listed here inasmuch as various models may have different characteristics. The type being supplied (1943) which is manufactured by the Devilbis Co. (model 502), has the limiting depths listed in the instruction books. Any other air compressors not designed as a source of diver's air should have its capacity at various pressures closely checked before using. Any compressor must supply at least 2 cubic feet of compressed air per minute measured at a pressure equivalent to the diver's depth. This air must of course be free from noxious gases and odors.

Gasoline driven  
air compressors.

Air Supply  
General

In the above paragraphs it will be noted that various instructions are given as to the minimum amount of air to be supplied to divers, i. e.:

- (1) In using the hand pump, 1.5 cubic feet per minute is given as the minimum.
- (2) In calculating the time that high pressure accumulators can be used for diving 4.5 cubic feet per minute, is taken as the standard.
- (3) In the gasoline driven air compressors 2 cubic feet is given as a safe minimum.

It has been found that 1.5 cubic feet of air per minute entering the helmet is the absolute minimum amount which will keep the percentage of CO<sub>2</sub> in the helmet within permissible limits. As the diver works harder his output of CO<sub>2</sub> increases, and a limit of 1.5 cubic feet per minute is not sufficient. Four point five cubic feet per minute has also been found to supply sufficient ventilations under all conditions of work. Thus, in the case of the hand pump, the minimum is taken since if the ventilation is not sufficient, the number of revolutions per minute can be increased, or the diver brought up. The gasoline-driven air compressors with 2 cubic feet per minute as a minimum provide more ventilation and will permit more work by the diver before he must be surfaced. In the case of the air flasks the maximum amount plus some wastage must be used in calculating the time the flasks can be used since if a lesser amount were used, the air supply could be exhausted sooner than expected if the conditions of work were more arduous than assumed.

Lubrication,  
General

In the past, castor oil was the only oil approved for use in compressors supplying air to divers. Because of the fact that castor oil has become a critical item, tests were conducted at the Experimental Diving Unit on various oils to determine their suitability. Navy symbol 2190T was found to be satisfactory. No high-grade lubricating oil gave off noxious gases although some produced odors unpleasant to the divers.

Submarine  
rescue vessel's  
diving air  
plant.

The operation of the air system is an important part of the diving, rescue, and salvage routine. An officer should be placed in charge of the plant, and his duties should be to start the system and route the air as ordered by the officer in charge of diving operations, who shall be a graduate of the deep-sea diving school. He should stand a continuous watch, assisted by a chief petty officer, and insure that the desired temperatures in the diving air mains are maintained. He should keep the officer in charge informed of these temperatures and pressures, and only in an emergency make changes except as ordered. When diving, rescue, or salvage operations are in progress, and air is being used for both diving and blowing purposes, it is necessary to safeguard the diver's air supply; therefore, orders shall be such that they will insure against opening or closing any air valve without the knowledge of those supervising the diving. The plant officer should always inform the chief engineer when the operation of additional compressors is needed.

It is customary, when diving is in progress, to have one or

both 400-pound compressors running on their governors, though air in sufficient quantity can be supplied by one. The reason for two compressors running is that, should one compressor fail, the other is available immediately to take up the load. The governors are set so that the compressor pumps against a certain pressure. If one should stop, the other can be speeded up immediately, thereby maintaining the air in the volume tank at the desired pressure. Further, with both machines on the air supply line, the load is divided, and the safety factor of each compressor is increased. The air ends of the compressor should be cleaned each night after diving has ceased. The valves should be removed, cleaned with soapy water, and wiped off with a castor oiled rag. The high-pressure air banks should be kept charged to their maximum capacity as emergency diving air supply, in event of failure of the air compressors. The banks are connected to the diver's air hose through a reducing valve that reduces the air to the desired pressure.

Dehydration  
of air supply.

The diving air plants installed on the submarine rescue vessels have 400-pound compressors which permit reaching a low dew point and give a greater volume of air gained through expansion down to 300, 200, or 100 pounds, as required. This system also has two after coolers. This complete circuit includes the volume tank, all heaters, and all coolers.

Since the relative humidity at no time is sufficiently low to insure the delivery of air from the compressors at less than 100 percent humidity, the relative humidity of the atmospheric air is not a determining factor in regulating the dew point of the air supplied to the divers. The relative humidity of the atmospheric air is, however, a gage of the amount of moisture in the air which has to be extracted during the reconditioning process, and serves as a means of regulating the interval of blowing down the coolers. When the relative humidity is from 50 to 70 percent, the coolers should be blown every 15 to 20 minutes; if from 70 to 80 percent, they should be blown every 15 minutes; and if it is 80 to 100 percent they should be blown every 10 minutes.

To use this system intelligently, we must know how to use a table called "Dew point temperature curve" (pl. 86), and have a knowledge of the following definitions:

*Dew point* is that temperature at which air is saturated and below which precipitation of moisture occurs. It varies with the humidity of the atmosphere.

*Absolute humidity* is the mass of water vapor present in the atmosphere, usually grains per cubic foot measured as per pound of air.

*Relative humidity* is the ratio between the amount of water vapor as determined by the existing dew point, and the amount that would be present if the dew point corresponded to the wet and dry bulb readings. When air is saturated, the dew point, wet bulb and dry bulb readings are all the same.

An inspection of the dew point temperature curves will show, by comparison of the column marked "Temp" with the figures set opposite the various temperatures, that a change in temperature causes a change in humidity; e. g., saturated air at 40° F. con-

tains 2,849 grains of water vapor per cubic foot, whereas at 30° F. it contains 1,935 grains; therefore, cooling will cause precipitation.

The amount or percentage of dehydration that it is possible to produce by a reduction of dew point depends entirely on the temperature it is possible to attain by the air cooling systems of the plant. In this case having produced a reduction of 10°, i. e., 40° F. with 2,849 grains of water vapor to 30° F. with 1,935 grains water vapor, the difference of 0.914 grains per cubic foot of air would be precipitated in the form of water which at a temperature of 30° F. would form slush ice, and could be discharged from the cooler through the blow valve. The air will now be 100 percent saturated for the new temperature, i. e., 30° F., and a further drop in temperature will cause further precipitation. As the cooling agent consists of the circulation of sea water through the cooler, it is obvious that the degree of dehydration possible by cooling depends entirely on the temperature of the sea water. In this case 30° F. would be called the dew point temperature since the air is saturated. However, a further reduction of the dew point may be brought about by expansion as follows: 34° F. (table 133) contains 2,279 grains of water vapor per cubic foot. Initial pressure of air from the compressors at 150 pounds (gage) or 164.7 pounds (absolute) and the reducing valve to be set at 100 pounds (gage) or 114.7 pounds (absolute), the air passes through the cooler. The reduction in pressure from 150 pounds to 100 pounds has, in accordance to Boyle's law, reduced the density of the air to approximately 70 percent. Therefore, the air instead of having 2,279 grains of water vapor, now contains only 70 percent of 2,279 grains or 1,595 grains of water vapor. Thus, we have reduced the dew point to 25.5° F. by a reduction in pressure. Hence, diver's air at temperatures above 25.5° F. would not precipitate moisture and no freezing could occur.

To use the curves, run a line from the dew point temperature scale to the percent pressure scale. From this intersection drop a perpendicular line to the initial pressure curve, and from this point run a line to the dew point scale. Using the dew point as indicated on this scale, the grains of water vapor will be found by reference to the inserted table. Otherwise the perpendicular line between the percent pressure and initial pressure curves can be extended to the base and the figure for aqueous vapor determined by interpolation.

From service tests of the air conditioning plants on Submarine Rescue Vessels, it never has been found necessary to reduce the aqueous vapor below 1.355 grains. Since air that is dehydrated completely would probably be injurious to the diver, the dew point should not be lowered beyond that necessary to prevent freezing of the diver's air line.

In addition to the expansion caused by the main reducing valve, there is a further expansion at the diver's air-control valve. Hence, without the reducing valve, the air pressure at the diver's air-control valve that allows a drop in pressure of 15 pounds would be reduced from approximately 135 pounds (the pressure

in the diver's air line) to approximately 45 pounds per square inch (gage). With the reducing valve in operation and set for 85 pounds, the expansion may be from 85 pounds per square inch to 45 pounds per square inch, thus the original factor of 3 to 1 is lowered to a new ratio of 2 to 1.

With the air-conditioning plant in operation, it has been found possible to maintain desired air temperatures by the use of bleeders. These are short lengths of hose, one to three in number connected to outlets on the diving mains on the opposite side from which diving is being conducted and are weighted a few feet below the surface of the water to eliminate noise. To raise the temperature in the diving air mains, it is necessary only to increase the flow of air by opening bleeders as much as necessary; to decrease the temperature in the diving air mains, decrease the flow of air and cut out the bleeders. The following is a facsimile of the title heads of a record that should be kept of the temperatures of the air during the use of the air-conditioning plant:

Air temperatures.  
 Water at surface.  
 Water one-half way down.  
 Water at bottom.  
 Humidity.  
 Air to cooler.  
 Air from cooler.  
 Water to cooler.  
 Water from cooler.  
 Air lines—Port.  
 Air lines—Starboard.  
 Diver's air hose from starboard side.  
 Bleeders from port side.

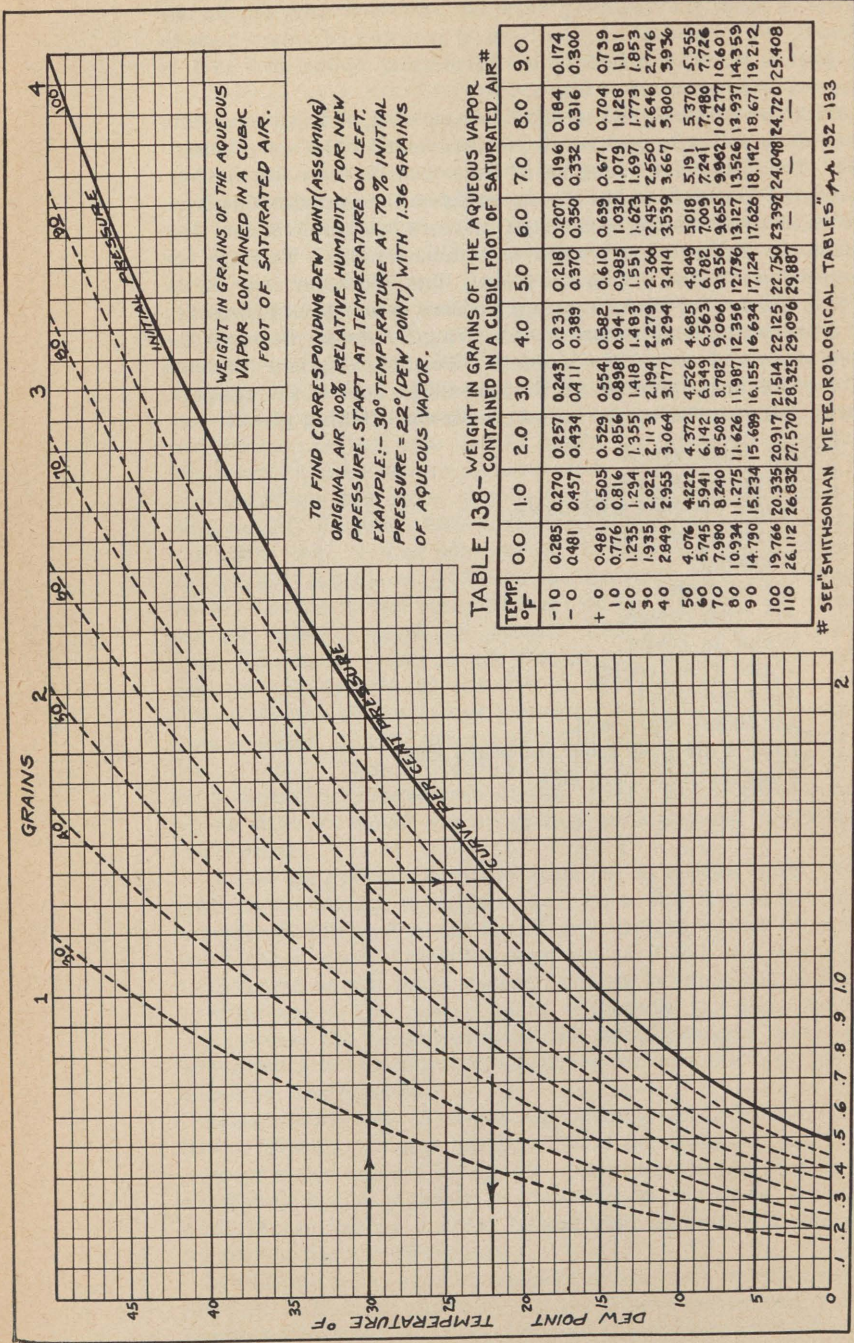

PLATE 86.—Chart—Dew point temperature curve and table of weights in grains of the aqueous vapor contained in a cubic foot of air.

## CHAPTER X DRESSING THE DIVER

The officer or diver in charge shall see that the diver is properly dressed, the air hose and all air connections properly made, oil cocks on pump cylinders (if pump is used) closed, and all gear properly arranged on deck or in the diving launch before the diver begins his descent.

Officer in charge.

The diver puts on the woolen shirt, drawers, and socks which are supplied. In cold weather, he should put on additional woolens. Then, he gets into the dress with the help of the attendants, and puts his arms into the sleeves. If the dress is gloveless, an assistant spreads simultaneously each cuff by inserting his first and second fingers of each hand, while the diver, taking care to keep his fingers straight, forces his hand through the cuff. Soapsuds rubbed on the inside of the cuffs or dipping the cuffs and diver's hands in fresh soapy water facilitates this operation. If rubber wrist bands or "snappers," plate 19, figure 2, are required, they are put on over the edges of the cuff. However, the effect of cold water together with the restriction of the circulation of the blood caused by the rubber wrist bands often results in a loss of the sensation of feeling in the hands so that there is danger of damage or injury to the hands when using tools. Accordingly, for work in cold water, a diver should be dressed in a suit fitted with gloves. Next, the canvas overalls, if used, are put on. Then, the diver sits on the dressing stool, plate 69, and the assistants place the weighted diving shoes on and secure them, by halyard lacings and buckled straps, to the diver's feet. Lanyards should be well secured around the ankles and the straps pulled tight and buckled. Buckles should be outward.

Dressing diver and arranging gear for diving from ship's deck.

The helmet cushion is put on, followed by the breastplate. Care should be exercised to prevent the rubber collar from being torn when it is pulled up and placed over the projecting studs. The bib is drawn well up, and the rubber collar is placed over the front and rear studs, working it over the remaining studs in succession toward the shoulder studs, alternately pulling up on the bib. The diver may, by elevating his arms, assist getting the holes in the collar over the shoulder studs. The reverse of this procedure should be followed in removing the collar from the studs when undressing a diver following a dive. Four oval-shaped copper washers (2 1/4" x 1 1/4" by 16-gage) are now placed on the studs where the breastplate straps join. The four breastplate straps are placed over the studs on the rubber collar. The wing nuts are then run onto the studs; those on each side of the straps' joints are screwed tight first, and those at the joints last. If a dress with gloves is used, the wrist straps are now applied. Next,

the weighted belt is fastened on, and the diver stands and bends forward while the jock-strap is properly adjusted.

During the time the diver is being dressed, the helmet should be examined, the valves tested, the telephone tested, the proper decompression tables looked up, and the necessary length of diving hose coupled up, care being taken that a washer is in place in each female coupling. Air should then be blown through to clear it of any dust and the hose tested to pressure a little higher than that in which the diver is going to work.

Again, the diver sits and the telephone headset (if the type of telephone used requires a headset) is put on and the helmet, with the faceplate open, is screwed in place. The safety catch is turned down into its recess, the recess closed by the hinged stopgap, and the split securing pin inserted. The combination telephone and life-line cable, and air hose are brought up under the right and left arms, respectively. The combination telephone and life line is then secured to the metal eyelet located on the right front (as worn) of the breastplate by means of the cable clamp provided with the amplifier type telephone outfits. The air hose is secured with a lanyard by two round turns and a square knot to the metal eyelet located on the left front of the breastplate. The 3-foot length of air hose (pl. 6) and the air-control valve shall be in place. Air is turned on the manifold or the pump started, as the case may be, so that the diver may test his air supply. The telephone should also be tested by the diver. When the diver understands the work he is to perform and is ready to dive, he is assisted by an attendant on either side, to the diving stage, steps aboard, and grasps the iron bales. When the officer or diver in charge is satisfied that all is in order, the air is started, the helmet faceplate is closed and the air regulating exhaust valve closed and reopened the desired number of turns to provide proper ventilation and buoyancy. The diver is then hoisted clear of the ship's side and the descent begun.

For diving operations from motor launches, the diving dress, shoes, and breastplate are put on the diver while seated in the boat. While the diver is being dressed, the diving gear should be looked over and tested as in diving operations from ships' decks. If air pumps are used, they should always be worked in their chests. The securing nuts for wheels and handles should be firmly set-up with a wrench, the hinged flaps covering the gages opened, the screw cap on the overflow nozzle removed, the cistern filled with water, and the pump tested. If air flasks are used, see that they are properly secured from rolling; that all connections are properly made; that all valves, including stop valves, are free to operate; and that proper tools are at hand to relieve a stop valve in case it should stick in closed position. Note the pressure in each flask; see that the valves on the manifold are properly turned and that the outlet nipples not in use are blanked off. Examine the air-control valve carefully and see that it functions properly.

The diving ladder is secured in position over the side of the boat and to the leeward. The descending line is put over abaft the ladder, leaving room for the decompression stage. Soundings

Dressing  
diver and  
arranging  
gear in  
diving launch.

are taken. Normally the stage is not placed at the first decompression stop until the diver has reached bottom. The arrangement of the ladder, stage, and lines are shown on plate 84.

After the diver is properly dressed, a manila safety line tended by two men is secured around him, under the arms, and he then climbs over the side and stands on the diving ladder, with his waist at the level of the gunwale on which rests the weighted belt. The diver leans over the gunwale, the weighted belt is fastened and the jock strap adjusted. Next, the helmet is screwed in place and secured, the air started, the air-regulating exhaust valve properly adjusted, and the manila safety line removed. When the officer or diver in charge is satisfied that the gear in the boat is properly arranged and in order, the diver descends on the ladder until the helmet is slightly below the surface of the water, assures himself that everything functions properly, reports "O. K." over his telephone, and begins his descent.

## CHAPTER XI

### THE DESCENT

#### Precautions in the descent.

The diver remains on the stage or ladder until he assures himself that his dress is tight, air valves and telephone in working order, and after reporting such by phone or signal, he steps off and is hauled by the tenders to the descending line that is, usually, made fast at the point where the stage is put over. The diver locks his legs around the descending line and holds onto it with his right hand, while he adjusts his air supply with the left hand before he starts the descent. He then starts on down at a speed which will permit him to equalize pressures and "pop his ears" but must be prepared to check his rate of descent whenever necessary. Since the time required for descent is included in the time of exposure, it is desirable that the diver arrive on bottom as soon as possible. The factors limiting the rapidity with which a diver can descend: Possibility of squeeze, inability to equalize the air pressure on both sides of the ear drum, pains in the sinus passages, the tendency toward dizziness, and the necessity of approaching the bottom cautiously, as, for instance, when entering a wreck.

When descending or ascending in a tideway, the diver should keep his back to the tide so that he will be forced against the descending line and not away from it. It is not difficult for him to maintain this position if he determines which way the tide tends to swing him and pushes the descending line over to one side or the other so as to check the swing. In addition to the conditions set forth in the preceding paragraph as governing the rate of descent, currents are also a factor.

#### Ear pains.

Pain in the ears during descent is a warning that must not be neglected, as rupture of the ear drums is threatened; see chapter XVII, Diving Accidents. The remedy is for the diver to stop his descent and yawn, swallow, or press his nose against the wall of the helmet, to block the nostrils, and make a strong effort at expiration. Ascending 3 or 4 feet usually provides relief, and the descent may be continued. If the dive is to be made in deep water, and the diver has trouble with his ears in getting down to 30 feet, it is advisable to bring him to the surface and not let him dive that day. Pain in the sinuses is usually caused by head colds, and the only remedy is to prohibit the diver from diving until his cold clears up.

#### Air supply and helmet ventilation.

As the diver descends, care must be taken that air is supplied to him in the correct volume and at the pressure corresponding to his increase in depth. Insufficient air supply during descent may force the diver to stop because of squeeze. See chapter XVII, Diving Accidents. As the diver descends, air is forced out

through the air-regulating exhaust valve by the pressure of the water, so that the dress becomes closely pressed to the legs, arms, and body up to the breastplate. The reason for this is discussed in chapter VII, The Physics of Diving. The experienced diver adjusts the air supply so that he breathes easily and comfortably without endangering his stability.

Upon reaching the bottom, the diver holds onto the descending line and adjusts his buoyancy to such a degree that the helmet merely lifts the weight of the apparatus off his shoulders. He also checks his ventilation and should spend 30 seconds to a minute at the descending line to permit his body to adjust itself at the new pressure level. See chapter VII, The Physics of Diving. The warning signs of CO<sub>2</sub> poisoning are thoroughly discussed in chapter XVII, Diving Accidents, under the heading of "Asphyxia."

## CHAPTER XII

### TENDING THE DIVER

Tending the diver is a task requiring both a knowledge of diving and care on the part of the tenders. Therefore, the tender should be an experienced diver. While tending a diver, he shall not perform any other work.

Signals.

All signals made and received and all sudden movements of the diver, or anything that seems to indicate that he is in difficulties, shall be reported by the tender to the officer in charge. The tender must remember the length of hose extended to the diver and should continually inform the officer or diver in charge of the length out while the diver is descending, on the bottom, and ascending. The tender receiving a signal shall repeat it as received to show that he has understood it. A signal should never be repeated unless what is meant is clearly understood, and if a wrong answer is received, the signal should be repeated until it is correctly understood. In case the diver does not answer a signal, after two or more trials at short intervals, ask him if he is all right, but if he does not now answer, haul him up to the first stop of decompression and try again. If he still does not answer, there is nothing left to do but to bring him to the surface. When a diver makes a signal and his attendant does not answer, it may be because there is too much line out and the signal is not received, hence the diver should gather in the slack and repeat the signal.

Since the life line and air hose are made into one line (by seizing) to lessen the danger of fouling, the signals cannot be made separately on either the life line or air hose. Under ordinary circumstances the following code shall be employed.

NOTE: Hand signals should be considered the primary method of communication.

#### FROM DIVER

- 1 pull means..... I am all right.
- 2 pulls mean..... Lower or give me slack.
- 3 pulls mean..... I am coming up.
- 4 pulls mean..... Haul me up.
- 5 pulls mean..... Send me a rope.
- 2-1 pulls mean... I. understand, or, answer telephone.
- 3-2 pulls mean... More air.
- 4-3 pulls mean... Less air.

#### FROM ATTENDANT

- 1. pull means..... Are you all right? (When diver is ascending, 1 pull means stop.)
- 2 pulls mean..... You have come up too far. Go down until I stop you.
- 3 pulls mean..... Stand by to come up.
- 4 pulls mean..... Come up.
- 2-1 pulls mean... I understand you, or, answer telephone.

Four pulls repeated several times in quick succession is the emergency signal.

Other signals will, of course, be arranged to suit the exigencies of the particular work in hand. Care must be taken, however, not to confuse the regular code.

Special  
Signals

Two pulls repeated several times quickly shall mean the diver is fouled and the assistance of another diver is required. On receiving such a signal, answer it as received, but make no attempt to haul the diver up. Send the relief diver down as soon as possible. Three pulls repeated several times in quick succession shall mean that the diver is fouled, but can clear himself if let alone.

Foul signals.

If the combined life line and air hose becomes turned around the descending line, it may become impossible to send or receive signals by this means, and the turns must be taken out as soon as they are noticed. One pull repeated several times in quick succession on the descending line will indicate that the life line and hose are fouled. If, after a trial, they cannot be cleared, the diver should be hauled up. It may become necessary to haul the diver up along with his descending line and weight. In this event, if the weight is heavy, the diver must try to cut it adrift and time should be given him for this purpose. Because of the possibility of his lines becoming fouled around another line, a diver should ordinarily not be permitted to descend on a line he cannot cut. On occasions it may be imperative or highly desirable to use steel rope or chain. The selection of the descending line to be used is left to the judgment of the officer or diver in charge.

Since signals cannot be received on a slack line, the line should be pulled up until the diver can be felt, and then the signals be made gently but distinctly. A sudden jerk may cause harm to the diver.

It is embarrassing for a diver to find his lines too taut, so that he is being continually pulled away from his work. If he is diving without telephone, it is difficult for him to make his attendants understand that they are holding him too tight. In attending the life line and air hose, the diver should be given 2 or 3 feet of slack when he is on the bottom, but not so much that he cannot be felt from time to time so as to make sure that there is not too much slack out. It should be remembered that a diver at work may sometimes be in such a position that he cannot answer a signal for several seconds, and a reasonable time should be allowed before the signal is repeated.

Judgment must be used in interpreting signals, and the attendant must consider what they are most likely to refer to. For instance, suppose a diver is going down. It should be known from the gage and the marks on the life line and the hose when he gets close to the bottom, and if the tender gets one pull on the life line about that time, it means of course that the diver has reached the bottom, but if the tender gets one pull while the gage and the marks on the lines should show that the diver has not yet reached the bottom, the meaning would be to "Hold on"; the diver has probably let go the descending line, or for some reason wants to be held by the life line and air hose. When the diver is on the bottom and near the descending line, also watch the lat-

ter for signals, as the diver may want it lowered or the slack taken up. If at any time there is anything seriously wrong, the diver should ask to be hauled up, by signaling four pulls on the air hose and life line. Four pulls on the air hose repeated is the emergency signal and the diver must never use it unless something serious has happened. There must be no delay in obeying it.

In case either the diver or attendant fails to get an answer over the telephone, the telephone signal should be made to indicate to the other that he is trying to talk over the telephone. He should wait a few seconds and try again and if now no answer is received, it should be assumed that the telephone is out of order and resort must be made to the hand of signals. If on the other hand after answering a telephone message, the same message is repeated several times, and no attention is paid to the answer, the person receiving the message should acknowledge that he understands it by making the telephone signal (2-1).

In deep water when a strong tide is running, signaling by ordinary methods is very difficult. Therefore diving under these conditions should not be attempted without a telephone in good working order. Under these circumstances if the telephone should fail, the diver should ascend or be brought to the surface.

In case of accident or emergency, it may be necessary to get a diver to the surface as rapidly as possible, despite the possibility of compressed-air illness. Under these conditions the speed of the ascent will depend on:

(a) Nature of the accident or emergency.

(b) Depth and length of exposure at which the diver has been working.

(c) The proximity of a recompression chamber ready for immediate use.

In any case when a diver fails to answer his telephone or signal, he shall be started toward the surface immediately. A pause should be made at the first stage of decompression, and another attempt made to communicate with him. If no answer is received, remainder of the ascent must be made according to the judgment of the officer or diver in charge.

If there is reason to suppose that the diver can be sent down again immediately, or a recompression chamber is ready for immediate use, a chance should be taken on a fairly rapid ascent for the remaining distance.

If a diver loses his distance line and cannot locate his descending line, it becomes necessary for his attendants to haul him to the surface. In this case, the diver shall notify the attendant to pull him up and not waste time searching for the descending line.

In hauling a diver to the surface care must be taken not to bring him up too rapidly as overinflation of the dress due to expanding air may cause him to be "blown up." Under this condition the diver should regulate the inflation of his dress so as to be heavy on the lifeline. The attendants should always keep the diver ascending very slowly until he reaches the decompression stage. They should cease hauling if it is found that he is becoming too light, but continue to take in all slack on the life line. Trouble in this respect may be experienced when the diver

Emergency ascents.

is unconscious or helpless. The diver should not be brought up beyond his first stop as indicated by the decompression tables. As the diver reaches this stop, he may be worked over to the decompression stage and if he is conscious no trouble will be experienced in landing him on it. If it is impossible for the diver to find his descending line at any depth, he should be brought to the surface and taken over to the descending line, his lines cleared, and again lowered to the decompression stage. In case the diver is helpless, decompression should be carried out as described for surface decompression.

Whenever a diver is working clear of the bottom, as on a ship's deck or on a stage under a ship, the attendants should always keep the lifeline and airhose well in hand. If under these conditions it was noted that the bubbles were moving rapidly in a straight line, it would indicate that the diver had fallen; therefore tightly grip all lines and quickly gather in the slack, and if air is being furnished by hand pumps give the diver "More air." Then ask him if he is all right, and if an affirmative reply is received, reduce the air supply to normal and await developments. In any case where there is danger of a fall, keep a tight hold on the diver's lines and do not give out any more slack than necessary.

The air bubbles rising to the surface from the diver's helmet must be watched constantly and if they disappear for more than one or two minutes, ask him if he is all right. If the mass of bubbles appearing on the surface is moving around, there need be no fear as to the diver's physical well-being. However, if he remains perfectly quiet, i. e., his bubbles remain in one spot, and he cannot be felt moving by the life line he should frequently be asked if he is all right.

During diving it is possible to follow the operations of divers and to know where they are and what they are doing by the following methods which are briefly described:

(a) The operation of a pneumatic drilling machine can be detected by feeling the supply air hose at almost any point due to the peculiar variation of pressure within the hose when the machine is actually running.

(b) The operation of a pneumatic hammer can be detected in the same manner. When divers are working with pneumatic hammers or with hand hammers and chisels of fairly large size, it is also possible by listening in the after hold of the salvage vessel to hear every blow that is made.

(c) The operation of an arc torch can be detected by observing the ammeter connected in series with it.

(d) The operation of a gas torch may be detected by the flow of gas past the reducing valves that is indicated on adjacent gages. Also when the torch is lit, the noise can almost invariably be heard over the telephone of the diver who is operating it and the large bubbles of gas from the torch break on the surface and emit small bubbles of smoke.

Observation of air bubbles and prevention of diver from falls.

Conditions indicating divers' location and nature of work being performed.

## CHAPTER XIII

### WORKING ON THE BOTTOM

Air supply  
adjustment.

On arriving at the bottom the diver should remain at the descending line long enough to regulate his apparatus and get adjusted to the new pressure level, the reason being that in descending the pressure of air is accelerating and when the diver comes to rest, the air supply is, as a rule, either too little or too much. Generally the former condition prevails. In either case, it is absolutely necessary to the diver that the inflation of his dress be exactly right. This is obtained when the diver so regulates his air supply that the helmet and breastplate will be just lifted from his shoulders and yet not destroy his negative buoyancy. Next, he must notice the ventilation of the helmet. While he is thus standing in a position of rest, his physical condition should be normal and the diver should feel comfortable. If his breathing is rapid, if he is panting for breath, perspiring unnaturally, experiencing an undue sensation of warmth or dizziness, if his eyesight is not clear, or if the helmet windows become cloudy from collected vapor, there is bound to be an accumulation of CO<sub>2</sub> in the helmet, and the remedy is "more air." Therefore, the diver should increase the rapidity of circulation of air through his helmet, but at the same time maintain the correct inflation of his dress. Proper inflation of the suit and proper ventilation of the helmet can usually be attained by setting the helmet air-regulating exhaust valve at 2½ to 3 turns and further regulating the air flow with the air-control valve; however, this valve should never be closed completely. Experienced divers adjust the exhaust valve at the same time as the control valve; i. e., increase air supply, increase exhaust; reduce air supply, reduce exhaust. The air-control valve is operated with the left hand, thus leaving the right hand free to operate the exhaust valve. Dress inflation may be used to an advantage to lessen muscular exertion while at work. Without changing the adjustment of either the air-control valve or air-regulating exhaust valve, the air-regulating exhaust valve stem may be used to cause rapid deflation by pushing on it with the chin, or rapid inflation by grasping it with the lips. Also when working in awkward positions with both hands employed, the use of the button on the air-regulating exhaust valve stem becomes of special benefit. The supplementary relief valve or "spitcock" is also valuable for exhausting excess amounts of air.

If, with the valves adjusted for the erect position, the diver stoops down for more than a short time, air accumulates in his dress and makes him light; hence, when remaining bent over or when crawling on hands and knees, the diver must manipulate his chin valve or spit cock so as to allow air to escape freely. An inex-

perienced diver tends to permit too much air to flow through the helmet, thus wasting air, and rendering communication by telephone more difficult.

After adjusting the air supply the diver should clear his distance line and proceed to work with the least delay. Before leaving the descending line he should note the lead of his hose and life-line cable and assure himself that they have not fouled the descending line. He should also note the bearing of the brightest light (diffusion of sun rays) and the direction of the current. By remembering the direction of his work with reference to the direction of the sun while he was on the surface, it is easy for him to proceed in the desired direction. If, for instance, the sun shone in the left helmet window as he faced the direction of his work before starting his descent, the greatest amount of light should still shine in the left window of the helmet when on the bottom if the diver's position is the same as when on the surface with relation to the sun. If the diver can see well and is sure of his direction, he has merely to survey the field within the range of his vision, noting the formation of the bottom, the trend of hues, etc. If the light is poor, he can determine its direction by facing the light squarely and then turning slowly around to either side. If he turns to the right, the view out of the right side window will be dark and the view out of the left window brighter. Continuing to turn, the light will be on the back of the helmet and all windows will be dark, etc. If there is no light, the diver will have to depend upon the direction of the current for his guide. The slightest general movement of the water can usually be detected by an experienced diver; however, the current does not always flow in the same direction on the bottom as on the surface and consequently if the diver should start off in a wrong direction he should be warned by his tenders by telephone or signal. A warning or signal for him to go right or left means that he should first face in the direction from which his lifeline and air hose are tending, and then obey the order.

Upon leaving the descending line, the diver should proceed slowly and cautiously to conserve his strength. He should examine his immediate surroundings, and report any wreckage or obstruction encountered. As a general rule he should pass over, not under, these obstructions; hence by the same token, he should never pass under the keel of the diving boat, but should have his lines shifted if it is necessary for him to work on the other side of the boat. The diver should carry one turn of air hose and telephone cable on his arm, in order that a sudden pull from the surface would not cause him to lose his balance. He should allow the hose and cable to touch the deck or bottom behind him, but should not allow it to pile up or kink. In passing any standing object, the diver should keep in mind the side on which he passes so as not to foul his lines when he returns. In entering a wreck or when passing through doors, he should always proceed feet first, and never attempt to force his shoulders and breastplate through. When in the course of any of his work he feels the slightest symptoms of distress, he should stop, rest, and think the situation over carefully. If a diver is to

Movement on  
the bottom.

work in a place in which there is a danger of fouling, a second diver shall always be ready to go to his assistance.

A diver can move with ease in slack water, but as the tide or current increases, it becomes increasingly difficult to advance. This difficulty may be lessened by advancing in a stooping or crawling position, as by so doing, the area of his body exposed to the sweep of the current is reduced. The latter-mentioned position is the easiest one for a diver's navigation under water; however, as mentioned in the foregoing, every time he assumes a new position, he shall have to look out for the regulation of the inflation of his dress.

Working on  
rocky bottom.

On a rocky bottom the diver should be careful not to fall off a ledge of rock into deeper water, nor get his arm or leg caught in a crevice. If he should fall, he should check his descent by increasing his air supply valve and telephoning the attendant to "Hold on." This rule, of course, also applies to a fall under any other circumstances. If the rocks are sharp, as coral usually is, the diver should wear gloves. He should watch his air hose, so that it will not catch a turn around a rock, and should caution the attendant about keeping the slack well in hand. If the diver's lines get fouled, he should gather them up and retrace his steps by following the lead of the air hose and life line. If they happen to become fouled in opposite directions, he should ask the attendant to take in the slack on one of them, then the other. It is almost sure one will be clear. In the event they are both actually fouled and there is no other resource left, he should cut the telephone cable or life line, then follow up the air hose and clear it. Never permit too much strain to be put on a fouled air hose, lest it be parted.

Working on  
muddy bottom.

If a diver finds himself on a muddy bottom, he should not flounder around and stir up the silt; a cloud of mud will prevent him from seeing anything. For the same reason he should keep the lee side of his work if there is any current. If the bottom is very soft, he should spread himself out over it and not try to stand. He should make himself light by keeping plenty of air in the dress. By opening a cuff or elevating an arm or opening the spitcock and permitting excess air to escape, he may rid himself of excess buoyancy. If he sinks deeply in the mud, it is because of negative buoyancy; positive buoyancy will take him out; however, he should operate very slowly and cautiously. He should wiggle out of the mud as gradually as he can; otherwise, as he breaks loose, he is apt to be "blown up."

Divers have been known to work under many feet of mud and silt for long periods without discomfort. There is nothing to fear about mud, quicksand, and the like. On account of being in a substance of greater consistency than water, movements must, necessarily, be more deliberate, and, by the absence of light, all work must be accomplished by the sense of touch. In some localities, such as around piers and dockyards, much debris falls overboard, and there are apt to be old tin cans, bottles, etc., in the mud. These, of course, should be looked out for, and the hands protected by gloves.

When searching for lost articles, the diver should explore thoroughly and as expeditiously as possible the whole of the ground within the sweep of his distance line. To accomplish this, he should take up the distance line and go to the leeward of the descending line weight as far as he can see clearly; then coiling the distance line in one hand and keeping it taut with the other, he sweeps around in a circle. When he comes back to the place from where he started (which must be judged by some object on the bottom, his own footprints, the direction of the tide, a line stretched along the bottom for the purpose, etc.), he fleets out a short distance along the distance line and makes a fresh circle in the opposite direction, thus avoiding the twisting of his air hose and life line around the descending line. It is, generally, more advantageous to crawl on the bottom when searching, though in exceptionally clear water, a better field of vision may be obtained by walking. The diver should not fleet out too far, but should let each new circle merely overlap the preceding one.

Searching for  
lost articles.

When a diver has explored the whole of the ground in this way without finding the object sought, he may be certain that it is not within the reach of the distance line; hence the next step would be to have the ship or the diving launch moved so that a new area may be searched. Each time before the ship or the diving launch is moved, its position should be marked by a buoy so that a systematic search may be accomplished. When a number of buoys have been thus planted over a considerable area, the unimportant ones may be removed by the surface crew, the important ones, however, marking the boundary of the explored area should remain until the search is completed.

The diver may be unable to make a complete circle if there is much tide or current; in that case, it is necessary for him to work back and forth across the tide as far as he can reach, each time fleeting out a little farther along the distance line until he reaches the end, and then have the position of the diving boat shifted.

Still another method of searching is to plant two large buoys a long distance apart. A surface line of adequate size manila is stretched between the two buoys, and the diving launch with diver on bottom, is then ferried along, the surface line being taken over the bow and stern rollers of the launch, and the boat being given headway by pulling on the line or stopped by holding onto it, according to signal from the diver. The advantage of this method is that the speed of the boat is always under exact control.

Upon finding the object sought, the diver should, if possible, fasten his distance line to it, after which he may signal for a rope and have it hauled up or go up and make his report, as circumstances may require. An object once found can always be relocated by means of the distance line tied to it.

When a diver is required to drag a long length of life line and air hose after him, or when it is necessary for him to work around several corners, an additional diver or divers are of assistance to him in tending his lines at intervening locations on

Working  
around corners.

the bottom or on deck. Thus, if his telephone should fail, he could send signals to one of the divers tending his lines, who, in turn, would transmit them to the surface by telephone or signal over the first diver's lines, using his own lines only for signals affecting himself. However, it should be borne in mind that the greater the number of divers submerged simultaneously, the greater the possibility of fouled lines. Whether the benefits of this procedure justify the acceptance of the greater possibility of fouling depends on the emergency or circumstances involved. Procedure will be at the discretion of the officer or diver in charge.

Working  
about  
moorings.

When working about moorings, a diver should be especially careful not to get fouled. He should not dip under chains, etc., without having a distance line to show him the way back. As old moorings are often covered with sharp barnacles, gloves should be worn to protect the hands. A diver should not descend on a chain or wire if it is possible to do otherwise, and neither should a chain, wire, line, or weight be veered, lifted, or moved until the diver is clear of them.

When a diver is required to work with several lines, it is a good plan to have each of them of a different size or material or marked using colored rags, turns of small stuff, etc. so that he may know their individual purpose. He should never cut a line until he has made certain the purpose for which it is being used. Since a new line when under water shrinks and usually takes several new turns in it, it should first be lowered in the water by means of a weight and allowed to remain a considerable length of time before it is sent to the diver. Otherwise, if lowered alongside of another line, it is sure to become fouled. *For underwater work, cable-laid line is the safest and most useful.*

Recovery of  
an anchor.

In recovering an anchor, the line of the watching buoy should be hauled up and down, and the descending line weight dropped close alongside it. The diver can then go down his descending line, keeping the buoy line in hand as he descends, thus preventing his descending line from fouling the buoy line.

If a wire hawser has to be shackled onto an anchor, the task may be accomplished in the following manner:

Prepare the wire by fitting a large shackle to the eye and by stopping another shackle with its crown against the wire a short distance above the eye. The pins of both shackles should be fitted with lanyards to prevent their loss under water. Shackle the wire to the descending line or to the anchor buoy rope (if watching) by the upper shackle, which will act as a traveler, leaving the end of the wire free for the diver to handle. When the diver has found the anchor, he should signal for the wire, which should be carefully lowered to him, great care being taken to prevent the wire being dropped on the diver or too much being paid out, since large flakes on the bottom render it difficult to find the end and may foul the diver. After shackling on, the diver must come up before any attempt is made to weigh the anchor. If the anchor is any distance from the descending line, or the buoy is not watching, the diver should bend his descend-

ing line on or get another rope bent on, so that the lifting wire may come down exactly where it is needed. The same applies for raising other heavy weights, such as guns, torpedo tubes, etc., from a wreck.

Whenever a diver is working clear of the bottom, as on a ship's bottom, he should never run the risk of falling off, but should always have something substantial to hold on to and make the attendants keep the life line and air hose well in hand. He should never go under the keel of a ship and up the other side; if it is necessary to work on the other side, he should ask to have the boat shifted. It is dangerous for a diver to hold on to something overhead and climb around in that manner if he is far from the ground; all the air in the dress may escape out of the cuffs or through leaks in a torn glove, etc., in which case he may become so heavy as to precipitate a fall.

Guarding  
against falls.

The amount of work which can be accomplished on ships' bottoms by divers depends largely upon the nature of the work and the extent of stable accessibility that can be maintained by the rigging of lines, ladders, stages, etc., to the wreck. Two or more jacob's ladders lashed together side by side and weighted at the lower ends form a convenient arrangement to enable divers to work over the side of a vessel. If the ladder is hung from the ends of spars secured on deck and projected about 2 feet clear of the ship's side, the ladder is hauled under the bottom by hogging lines; the divers will have room to work, be able to move around freely, and be protected from falling, they of course being on the inboard side of the ladder. For working beneath the bilge keels of large vessels where the bottom is usually flat, a good plan is to lace a net between two jacob's ladders. The two ladders are separated by spars lashed in place so as to stretch the net, and the whole is passed under the keel by the aid of hogging and tricing lines. The diver can then lie back in the net and work on the bottom above him with comparative ease. When a diver is working under a ship, all lines, etc., must be carefully attended.

Working on  
ship's bottom.

Another method of rigging a stage which is very quickly made and has been found very suitable for the use of divers working on a ship's bottom is as follows:

Two long spars, 20 to 25 feet long, are suspended from each other about 4 feet apart by means of two long ropes, the bights being clove hitched around the end of each spar, the upper ends forming the tricing lines, and the lower ends the hogging lines. The tricing lines are to take the weight of the stage, and the hogging lines are for holding it down and binding it in to the ship's side. A third spar about 16 feet long is hung to the lower of the two long spars by means of a slung weight, so as to keep it in a horizontal position about 3 feet below the lower long spar, sufficient weight being hung to the stage to overcome its buoyancy. To prevent the stage being bound too close to the ship's side, crosses of wood can be used, made from any rough pieces about 3½ feet long, and secured in the form of a cross. One of these crosses is secured at each end of the upper spar, a small cleat nailed on the spar prevents the crosses from slip-

ping inwards, and the clove hitches of the stage ropes prevent them from slipping outward. This stage is suitable for two divers, and the stage can be raised or lowered bodily, the diver at each end making his own signals. When it is desired to fleet the stage, the divers should come to the surface.

Minor leaks

Collision mats, patent leak stoppers, mattresses, canvas, swabs, cotton waste, caulking, wooden wedges, cofferdams, etc., have all been used successfully in making emergency repairs to the injured hulls of vessels. There are no standard rules for the actual performance of such work. As procedure will necessarily vary with each undertaking, methods and facilities will have to be improvised to meet the emergencies of particular cases.

Minor leaks, small and medium size holes.

In general, small leaks such as leaky rivets, plate seams, and cracks in shell plating can be corrected by use of standard pneumatic caulking tools if time permits. A quick but less permanent method of stopping minor leaks is to use leak-stopping material such as sawdust, shavings, straw, or unraveled oakum. This material is taken down by the diver and released from a sack at some point below the leak. Being buoyant the material will rise until caught in the current produced by the flow of water from the outside of the ship to the inside through the small opening. The material released will lodge in the crack and will swell up, causing eventual stoppage of the leak. A better substance to use, if the exact location of the leak is known, is a mixture of 65 percent lamb tallow, 25 percent powdered charcoal and 10 percent portland cement and work this paste directly in the leaking seam.

Small holes, such as empty rivet holes, ruptured plate seams, etc., can readily be patched by using plugs and wedges of white pine or some other suitable soft wood. If the holes are in such a position that the wood plugs might become dislodged in the remainder of the salvage operation, it would be well to use bolts through the rivet holes with a washer on both sides. In using wedges to stop seam leaks, tallow, oakum, lead wire, etc., can be used as a caulking material to insure tightness. If wedges or plugs are driven from the inside, portland cement may be used to secure them in place and prevent leakage.

Holes of moderate size that are too large to close by use of a simple wooden plug, and too small to be closed by application of a large standard patch, can be temporarily closed by use of materials such as blankets, mattresses, pillows, or collision mats. When the compartment is later pumped down, a concrete patch can be fitted from the inside.

Large holes.

In brief, the general procedure for applying large patches is as follows: The diver must first go down and cut away all adjacent fractured or torn plate so that the patch will be secured on good solid plating. The size of the patch is then determined by using a plumb-bob suspended from the topside. The extremities of the hole are marked on the deck and the width of the hole is determined by the use of two square marks tied in the line by the divers. A frame to these dimensions is now constructed and lowered where it is temporarily secured in place so that battens might be used to make a templet of the curvature of the ship's

hull. The patch is again brought topside and built up to conform with the curvature of the battens placed by the diver. The framework is then covered by tongue and groove planking and the inside bearing surface of the patch is covered with a cow hair felt gasket about 4 inches thick. Ordinary planking may be substituted for the tongue and groove, and caulked with oakum or covered with canvas.

The patch is then weighted and drawn into place by means of hogging lines or block and tackle rigged for this purpose. If it is impossible to get to the bolts to secure the patch in place from the inside, the outside pressure will automatically seat the patch and hold it in place until it will become accessible when the compartment has been pumped down.

Valves, as a rule, can be easily cleared from the outside by means of a wire brush and a pricker to clear the holes. If barnacles have gathered inside the perforated covering, the grating must be taken off to destroy them. The position of the grating should be marked before removal to facilitate its replacement. In case of the removal of a valve, after the securing plate has been taken off, the hole plugged up, and the plug cut off flush with the ship's side, the outside should be covered with wood, lined with greased fearnought to prevent any leakage inboard. If the valve is only to be kept out a short time, this covering need only be temporarily fastened, as the pressure of the water on the outside keeps it in place.

Clearing valves and propellers

Propellers usually get fouled by rope or wire hawsers, and at times are most difficult to clear. A stage should be rigged near the foul part (an iron grating will answer the purpose) to enable the diver to work in comfort.

First, the fouling should be thoroughly examined to see if it is possible to clear an end; if so, and if the turns are jammed, rope ends or tackles from the surface must be got down and put on to break them out. Back turns can be taken, or the propeller turned by the jacking engine to insure the lead of the tackle being at its best, the diver and stage being out of the way when the propeller is being turned. If no end can be exposed, then the hawser must be cut. The engineer officer on duty must always be informed whenever a diver is working about the propellers.

Rope hawsers can be cut with a knife, hack saw, carpenter's chisel, etc. There are three practical methods of cutting fouled wire cables. The first, and probably the most expeditious method, is by use of the powder actuated cable cutter described in chapter XIX provided the diameter of the cable does not exceed 1 inch. The second is by burning with the underwater gas or electric torches described in chapter XIX. The third and most tedious method is by cutting the cable with a sharp chisel or saw.

Whenever a diver discovers that he has become fouled, he should not get excited, but instead, he should attempt to extricate himself by slow methodical efforts. The distance line should never be released as it is a safe guide, and will, generally, show the way out of a tangle. The diver should inform the surface crew to take up slowly the slack in his air hose and life line. After resting and again attempting unsuccessfully to free himself, he should ask for help.

Fouled diver.

The relief diver should follow down the fouled diver's air hose and life line in order that he may discover the tangle. However, if after discovering the tangle, he is unable to release the fouled diver, he should be prepared to substitute a new air hose and life line. To accomplish this, the relief diver fastens the new life line around the fouled diver's waist. Next, with the nearest free coupling of the fouled air hose at hand, the fouled diver closes his air-regulating exhaust valve and his air-control valve while the relief diver uncouples the fouled air hose and couples on the new one. If an air-control valve is not used, it is important that the hose coupling to be broken shall be at or below the level of the fouled diver's feet.

Loss of distance line.

The distance line may be lost by the diver, because of darkness when diving at deep depths. Should this occur, the diver should feel carefully on the bottom within his reach for it. But if, after this simple maneuver, he does not find the distance line, he should inform the surface of the loss and that he is coming up. The attendant should keep the air hose and life line close to the descending line, and as the diver is hauled toward the surface, it is highly probable that he will discover the descending line. As soon as he discovers the descending line, he so informs the surface attendants, signals them to "Lower," descends, and, with the distance line again in his possession, returns to work.

Sending down tools.

Tools that the diver is to carry down to the bottom with him are fitted with lanyards, and slipped over the diver's right forearm or are placed in the diver's tool bag held on the right forearm. In preparing the tool bag, all small tools, bolts, nuts, and small fittings are secured to the eyelets of the tool bag with approximately 3 feet of marline. See chapter I, Equipment.

When a power tool is to be sent down, it should precede the diver, and should be attached by a piece of 6-thread manila to a sliding shackle on the descending line, and lowered to the bottom by means of the tool's air hose.

An electric torch and ground wire or a gas torch and igniter may be sent down in the same manner as the power tool, except the ground wire or torch hose is used as the lowering line.

For all other objects, use 15- to 21-thread manila for a lowering line, led from well forward to prevent turns, attached by an eye splice to the sliding shackle on the descending line, the small objects being, in turn, attached by a short piece of marline to the shackle.

Rules.

In order to work efficiently and safely under water, a diver should keep in mind the following general rules and facts:

- (a) Never completely close the air-control valve, except during rupture or replacement of air hose.
- (b) The helmet air-regulating exhaust valve stem known as the *chin valve* may be used effectively to release quickly suit pressure when desiring to stoop or crawl on the bottom without changing the air-control valve and the air-regulating exhaust valve adjustment.
- (c) The helmet spitcock offers another method of relieving excess pressure in the helmet.
- (d) The safety valve in the helmet gooseneck and the helmet

air-regulating exhaust valve will seat themselves if the diver's air supply is impaired, but the spitcock, if open, must be closed immediately by hand.

(e) A diver is never in danger from a leaking dress provided he remains in an upright position. Divers have descended to a depth of 274 feet with helmet only.

(f) Air trapped in the diving helmet will last from 6 to 9 minutes for breathing purposes after diving air is cut off; thus providing ample time for emergency measures to be executed.

(g) In case a diver is fouled and cannot extricate himself, a relief diver that is sent down must be prepared to replace both air hose and life line—a procedure that may be safely executed on the bottom.

(h) Never become frightened or excited; slow methodical efforts are always best in any emergency. Inexpert divers have been known to actually worry themselves to death over very simple circumstances. Such a state of mind is both needless and useless. A diver should never make the foolish mistake of running away from his air supply, and consequently from safety; i. e., to become panic stricken and make violent exertions to escape from a tangle, when the proper course is to go slowly and deliberately. When in trouble, he should slow down his exertions and, if relief is not immediate, rest a while. No matter how serious the situation appears, a diver should remember that there was a way into his predicament, hence there is also a way out of it, and if he cannot solve the problem himself, that the relief diver and his friends on the surface will.

(i) A diver must have confidence, first in himself, and second, in those who are tending him.

(j) A diver should adjust his air in such a manner that he is enabled to breath comfortably.

(k) The combined discharge of air-regulating exhaust valve and spitcock will not overcome the flow of air that will pass a half-open control valve, hence movement of the control-valve wheel must be very small.

(l) The air-regulating exhaust valve adjustment should be set at the desired number turns open prior to dive.

(m) If a diver should crack his faceplate, he should keep his faceplate downward and increase his air supply to prevent leakage.

## CHAPTER XIV

### THE ASCENT

Stage decompression and methods of application.

The essential feature of the ascent is decompression of the diver. This is necessary to prevent contraction of compressed-air illness or, as it is more commonly called, "bends," "screws," "diver's paralysis," "caisson disease," etc. Its cause and the proper treatment for it are described in chapter XVI, Compressed Air Illness.

The most efficient, practical, and safe method of decompression is stage decompression, which consists of reducing the pressure in certain successive stages, in ratio with the pressure of the dive, and maintaining the reduced pressures for certain periods of time, depending upon the depth of the dive and time of exposure on the bottom.

It is possible to accomplish stage decompression by one of two methods. These are (1) regular decompression, and (2) surface decompression.

Regular decompression.

Regular decompression, as termed herein, consists of decompressing the diver in the water by bringing him up to the intervening and successive depths listed in decompression table I of this chapter, and maintaining him at these stops for the prescribed period before surfacing him. This method of decompressing the diver is standard and shall be followed in all cases except where emergencies or conditions of tide or weather are such as, in the opinion of the officer or diver in charge, warrant surface decompression.

Regular decompression in the water shall be accomplished as follows: The diving stage (platform) shall be lowered to the first decompression stop prescribed in the decompression table for the particular depth at which the diver is working. The diver after reaching the descending line and assuring himself that all lines are clear shall report to the tender that he is ready to ascend. Everything on the surface being in readiness the word is sent to the diver "all right—come up." The diver then places one leg around the descending line, as in the manner of descending, lightens his weight as necessary by inflating the dress, and ascends to the stage keeping his left hand on the control valve.

Surface decompression.

It will be noted from the accompanying table that following dives at deep depths and long exposures, the diver is required to spend long periods of time decompressing on the stage. Where local conditions of weather, tide, etc., are ideal, this does not constitute a hardship. However, local conditions are not always favorable to deep diving and where they are severe or liable to sudden change, the long decompression in the water does become a hardship and frequently presents a greater hazard than bringing

the diver directly to the surface without intervening decompression. When, in the opinion of the officer or diver in charge, such conditions do exist or arise during diving operations and the depth at which the diver has been working and the time of exposure are no greater than those prescribed for surface decompression in table II, the diver may be brought up to the first stop and decompressed at this stop as indicated in the appropriate table. He is then brought to the surface at a rate of 25 feet per minute, the stage is hoisted aboard, the helmet, belt and shoes are removed and the diver placed in the recompression chamber in the shortest possible time interval. The pressure is raised at once to the equivalent of the first stop. The decompression time of the first stop is repeated and the remainder of the decompression completed as indicated in the appropriate table.

This method is termed surface decompression and, contingent on the availability of a recompression chamber, is applicable to all emergency ascents.

Several factors must be kept in mind when using surface decompression:

(a) The time of exposure must be within the time limit listed in table II.

(b) The rate of ascent of the stage should not exceed 25 feet per minute.

(c) When on deck the diver must be placed as rapidly as possible under pressure corresponding to the first decompression stop listed in table I for the particular depth at which he was working.

The Bureau of Ships has been experimenting continuously over a considerable number of years with various methods of decompression with the view of correcting inadequacies found to exist in former tables and of reducing as far as is consistent with safety the time hitherto required for decompression in deep diving. The following tables which have been calculated as a result of this work are based on the saturation and desaturation rate of the 75-minute tissue, considered to be the slowest tissue of the body so far as regards saturation and desaturation. The great number of dives made by the Experimental Diving Unit during development of the tables in the water diving tank and open sea in depths down to 300 feet and their subsequent use by the Diving School for approximately 3 years have proved the tables to be safe. Accordingly, the new tables have been adopted as standard United States Navy decompression tables and should henceforth be used as such.

Decompression tables.

Table I lists the stops and the required decompression for depths of from 40 feet to 300 feet for various times of exposure at these depths. Table II lists the maximum time of exposure at various depths down to 170 feet, following which surface decompression may be used with reasonable safety.

In no case, except in great emergencies involving life or death and requiring the immediate surfacing of the diver, or except when specially trained diving supervisors and recompression apparatus are available, as on submarine rescue vessels, shall the optimum time on the bottom for the particular depth involved

be exceeded nor the decompression stops and time of stops as listed in table I be reduced. When this time is exceeded, the casualty treatment prescribed elsewhere shall be followed.

The length of time at each stop as listed indicates the time which must actually be spent at that stop and does not include the time necessary to pass from any stop to the next shallower one. The exposure time listed includes the time consumed in descending, i. e., the interval of time between leaving the surface and the beginning of the ascent in regular decompression and the interval of time between leaving the surface and the time the stage starts to the surface with the diver on it in surface decompression.

In extremely cold water, desaturation of the tissues is less rapid but the following table is adequate for all water temperatures which may be expected in normal service.

Decompression table No. 1

Depth of dive (feet)	Time from leaving surface to beginning of ascent for regular decompression or to "upstage" for surface decompression	Stops at different depths in minutes Except in emergencies speed on ascent between stops should not exceed 25 feet per minute.						Total time of decompression; sum of times at various stops	Approximate total time for ascent; column 4 plus time between stops
		Minutes	Feet 60	Feet 50	Feet 40	Feet 30	Feet 20		
40	120						0	1	
40	180						2	3	
40	Opt.* 240						4	5	
40	300						6	7	
50	78						0	2	
50	120						2	4	
50	Opt.* 190						5	7	
50	150						9	11	
50	300						12	14	
60	55						0	2	
60	75						2	4	
60	Opt.* 150						13	15	
60	180						5	20	
60	210						7	23	
70	43						8	28	
70	60						0	3	
70	75						4	7	
70	90						13	16	
70	Opt.* 120						4	20	
70	150						13	23	
70	180						16	29	
70	210						18	32	
80	35						21	39	
80	50						21	53	
80	70						32	56	
80	100						0	3	
80	Opt.* 115						6	9	
80	150						16	30	
80	30						20	33	
90	45						20	36	
90	60						22	39	
90	75						26	48	
90	Opt.* 95						28	51	
90	130						29	57	
100	25						0	6	
100	40						6	9	
100	60						16	30	
100	75						20	33	
100	Opt.* 85						16	33	
100	90						20	36	
100	120						22	39	
100	20						26	48	
110	35						28	51	
110							29	57	
110							0	3	
110							6	9	
110							16	30	
110							20	33	
110							22	39	
110							26	48	
110							28	51	
110							29	57	
110							0	3	
110							6	9	
110							16	30	
110							20	33	
110							22	39	
110							26	48	
110							28	51	
110							29	57	
110							0	3	
110							6	9	
110							16	30	
110							20	33	
110							22	39	
110							26	48	
110							28	51	
110							29	57	
110							0	3	
110							6	9	
110							16	30	
110							20	33	
110							22	39	
110							26	48	
110							28	51	
110							29	57	
110							0	3	
110							6	9	
110							16	30	
110							20	33	
110							22	39	
110							26	48	
110							28	51	
110							29	57	
110							0	3	
110							6	9	
110							16	30	
110							20	33	
110							22	39	
110							26	48	
110							28	51	
110							29	57	
110							0	3	
110							6	9	
110							16	30	
110							20	33	
110							22	39	
110							26	48	
110							28	51	
110							29	57	
110							0	3	
110							6	9	
110							16	30	
110							20	33	
110							22	39	
110							26	48	
110							28	51	
110							29	57	
110							0	3	
110							6	9	
110							16	30	
110							20	33	
110							22	39	
110							26	48	
110							28	51	
110							29	57	
110							0	3	
110							6	9	
110							16	30	
110							20	33	
110							22	39	
110							26	48	
110							28	51	
110							29	57	
110							0	3	
110							6	9	
110							16	30	
110							20	33	
110							22	39	
110							26	48	
110							28	51	
110							29	57	
110							0	3	
110							6	9	
110							16	30	
110							20	33	
110							22	39	
110							26	48	
110							28	51	
110							29	57	
110							0	3	
110							6	9	
110							16	30	
110							20	33	
110							22	39	
110							26	48	
110							28	51	
110							29	57	
110							0	3	
110							6	9	
110							16	30	
110							20	33	
110							22	39	
110							26	48	
110							28	51	
110							29	57	
110							0	3	
110							6	9	
110							16	30	
110							20	33	
110							22	39	
110							26	48	
110							28	51	
110							29	57	
110							0	3	
110							6	9	
110							16	30	
110							20	33	
110							22	39	
110							26	48	
110							28	51	
110							29	57	
110							0	3	
110							6	9	
110							16	30	
110							20	33	
110							22	39	
110							26	48	
110							28	51	
110							29	57	
110							0	3	
110							6	9	
110							16	30	
110							20	33	
110							22	39	
110							26	48	
110							28	51	
110							29	57	
110							0	3	
110							6	9	
110							16	30	
110							20	33	
110							22	39	
110							26	48	
110							28	51	
110							29	57	
110							0	3	
110							6	9	
110							16	30	
110							20	33	
110							22	39	
110							26	48	
110							28	51	
110							29	57	
110							0	3	
110							6	9	
110							16	30	
110							20	33	
110							22	39	
110							26	48	
110							28	51	
110							29	57	
110							0	3	
110							6	9	
110							16	30	
110							20	33	
110							22	39	
110							26	48	
110							28	51	
110							29	57	
110							0	3	
110							6	9	
110							16	30	
110							20	33	
110							22	39	
110							26	48	
110							28	51	
110							29	57	
110							0	3	
110							6	9	

TABLE II.—Limits of depths and exposure for surface decompression

	Minutes
100 feet.....	85
110 feet.....	75
120 feet.....	60
130 feet.....	55
140 feet.....	45
150 feet.....	40
170 feet.....	30

**Repeated dives.**

In considering precautions for insuring the safety of the diver in making his ascent, certain rules in regard to the number of dives an individual may make in short periods of time shall be observed. Specifically, a diver should not, except in emergencies, make more than one dive of any considerable depth in 24 hours. However, should it become necessary for one individual to make more than one dive in 24 hours, his ascent on the latter of the two dives should be governed by the following rule: Take the total combined time of exposure on both dives and use a decompression for that exposure at the depth of the latter dive.

**Timekeeper.**

The timekeeper shall keep an accurate record of the time required for the diver to reach the bottom, the time of exposure on the bottom, the time of ascent to the first stop, and the time spent at each stop during the subsequent ascent. If there is any doubt as to the time that the diver has spent on any phase of the ascent, the time allowance should be made in the diver's favor. These times shall be carefully kept and recorded as in the following example:

	<i>a. m.</i>
Entered water.....	10.00
Started descent.....	10.05
On bottom.....	10.07
Started ascent.....	10.30
First stop, 50 feet.....	10.32
Second stop, 40 feet.....	10.37

**Instructions to attendants.**

The attendant shall always keep himself informed as to the depth of the diver under water. This can be estimated by the length of hose out and, when diving with air pumps, by the pressure registered on the diving gages. The diving hose usually tends straight up and down, especially in shallow depths, provided that the sweep of the current is not too great. After the diver is on the stage the depth can be readily ascertained by the markers on the stage lines.

The attendant shall frequently contact the diver by telephone or signal while on the bottom and on the stage to ascertain if all is well.

The attendant shall give the diver a few minutes' notice before the expiration of the diver's time on the bottom, so that the diver can make the necessary preparation prior to his ascent and not exceed his limit of stay on the bottom.

During the time that the diver is making preparations for the ascent the attendant shall remove any slack in the lines,

rig and shackle the stage to the descending line, and select the proper decompression from table I for the dive. The stage shall then be lowered to the first stop for regular decompression as indicated in table I for the depth of the dive, or, if surface decompression is resorted to, then as close to the bottom as practicable. The stage may be shackled to the descending line so that it will be impossible for the diver to miss it on his ascent.

During the ascent the attendant must at all times keep a tight hold on the diver's air hose and the life line and the slack well in hand.

During the diver's ascent, in regular decompression, when his hose and life line or gages, as the case may be, indicate that he is approaching the stage, he should be notified to stop and then ascend slowly and watch out for the stage. Special care in this respect is necessary so that the diver shall not exceed a safe limit of ascent.

The time of decompression at the first and succeeding stops (regular decompression) shall be calculated from the time that the attendant receives from the diver notification that he is on stage.

In regular decompression the ascent is completed by hoisting and stopping the stage to and at the successive stops prescribed in decompression table I. Prior to hoisting of the stage between the first and successive stops, the timekeeper shall notify the diving officer sufficiently in advance of the termination of the prescribed time at the respective stop, to permit necessary preparation for the hoisting. For example, if the diver has been decompressing at the first stop and the time spent on the stage at the first stop is within 1 minute of the total time prescribed for that stop, the timekeeper shall indicate it by distinct announcement of "one minute to go." The diver is then notified by the tender to stand by for hoisting to the next stop. The timekeeper shall announce the termination of the proper time at the various stops and before starting the stage upward, the diver shall be apprised by the tender of the intended hoisting by the message "coming up." On confirmation reply from the diver, the diving officer or diver in charge may order the diver brought to the next stop.

When the stage arrives at the surface after regular decompression, it is lifted and swung clear of the gunwale, lowered lightly to the deck and the diver assisted from the stage. As soon as the diver is seated, the face plate is opened and the air-supply valve closed. If a recompression chamber is available, the diver is undressed at once. If a recompression chamber is not available, the diver's helmet is removed but he should remain dressed for at least 20 minutes and closely observed for symptoms of compressed-air illness. At the end of this period, if the diver's condition appears normal, the diving dress may be removed.

When the stage arrives at the surface preparatory to surface decompression, it is lowered to the deck as before. The diver's helmet belt and shoes are quickly removed and he is escorted to the recompression chamber by the attendant, who enters the

chamber with him and removes his suit as the pressure is raised to that corresponding to the first decompression stop. Not more than 2½ minutes should elapse from the time that the stage leaves the water until the diver is inside the recompression chamber and is again being subjected to pressure.

It is well for the diver to remain in the vicinity of the recompression chamber or facilities for underwater decompression for at least an hour following the completion of a deep dive, even though there has been no indication of compressed-air illness during the 20-minute period mentioned. When extremely deep dives have been made, it is advisable to keep the diver aboard ship where he can be observed for at least 8 to 10 hours. If there develop any indications of compressed-air illness, the diver should be recompressed and decompressed in the recompression chamber in accordance with the treatment prescribed in chapter XVI. If a chamber is not available, recompression and decompression should be accomplished by sending the diver down again.

If, during a diver's ascent on the stage in regular decompression, symptoms of compressed-air illness develop, or the diver suffers any physical distress, the tender, upon receipt of notification to this effect from the diver, shall lower the stage to the first decompression stop and have the diver undergo a second decompression. This second decompression shall be in accordance with table I for the depth of the dive but for double the actual exposure in the dive.

Instructions  
to divers.

After receiving instructions from the surface to come up, the diver shall make preparation for his ascent at once, i. e., get over to the descending line, see that he is clear, and that there is nothing to interfere with the ascent. If the ascent is to be with regular decompression, the next step is for the diver to throw one leg around the descending line as in descending, so that he will be able to check his ascent instantly, should he suddenly attain a strong positive buoyancy by overinflation of the dress. Then he shall notify the surface "Coming up." He shall not start his ascent until he has received the answer from the surface, "Come up" by telephone or corresponding signal. Keep phone message brief, use simple phraseology.

In order to facilitate his ascent, the diver may reduce his weight by inflating the dress. In thus lightening himself, he must be extremely careful as overinflation may result in his being "blown" to the surface. (See ch. XVII, Diving Accidents—"Blow-up.") The new type of air regulating escape valve described under chapter IV, Helmet, has contributed considerably to the prevention of this accident. However, the valve may become fouled or some of its parts made inoperative by accident, etc. Further, the diver cannot handle himself correctly on the descending line if he is too buoyant.

The rate of the diver's ascent up the line to the diving stage should not be greater than 25 feet per minute. This speed must be regulated by the surface attendants which requires that the diver maintain slight negative buoyancy. If the diver feels his dress becoming too buoyant and he is ascending too rapidly,

he may check his rise by clamping his legs on the descending line and adjust the inflation of his dress by adjusting the air-regulating escape valve. If the dress is not fitted with gloves, reduction in inflation of his dress can be rapidly contributed to by the diver raising his arm, which will permit excess air to escape at the cuff.

When the diver is warned by surface attendants that he is nearing the stage, he shall slow his ascent and keep a sharp watch for the stage, the guide being the sliding shackle holding the decompression stage and the descending line together. As soon as he finds the stage, he shall climb upon it and seat himself. When he has done this, he shall notify the surface, "All right on the stage" in order that the beginning of his proper decompression at this first stop may be started and timed.

During the time spent at the first and subsequent stops the diver should see that his lines are clear of the descending line and stage. In case of fouled lines, he shall report the fact immediately to the surface attendants and they shall aid the diver to unfoul the lines as much as possible. When fouling of lines is detected by the attendants, the diver should be apprised of the fact. When the lines are clear, the diver shall so notify the attendants, and the attendants shall confirm the fact by repeating back the message, before starting to hoist the stage.

During the diver's stay at the various stops, he should watch out for any untoward symptoms as pain, dizziness, etc. If he experiences any of these, he should notify the surface at once. The attendants will, after consideration of all the circumstances, either lower the stage immediately to the first decompression stop and cause the diver to undergo a second decompression or they will bring him to the surface as quickly as possible for surface recompression.

When the diver is ascending and is on stage, he should pay close attention to messages from the surface and in all cases endeavor to answer clearly those requiring an answer. When word is received from the attendants that the stage is to be hoisted, the diver should assure himself that his hold on the stage is secure before returning the "O. K." signal to the surface.

The foregoing instructions are also applicable to ascents for surface decompression so far as concerns the diver's ascent to the stage and procedure on the stage during its subsequent direct hoisting to the surface.

The foregoing instructions for ascents cover procedure in diving from vessels such as submarine rescue and salvage vessels which are properly fitted with hoisting and other diving facilities including a recompression chamber. The instructions are equally applicable to ascents from dives made from motor launches with regular decompression, except that the stage must be hauled up by hand instead of a powered winch. Under such conditions it is impossible to haul the diver to the level of and over the gunwale of the launch. Accordingly, the stage is hauled up until the diver can get aboard the ladder which he mounts until his waistline is abreast the gunwale. The diver is then secured to the side with the safety line and helmet face plate opened to ascertain his

Decompression  
in diving  
launch dives.

condition. If no adverse symptoms are evidenced, the diver is assisted over the gunwale by the attendants who place themselves on either side of his body and lift him by the arm pits and under the waist. The diver aids by bending his body forward from the waistline at approximately 90°. The helmet may be taken off but the diving dress is not removed for at least 20 minutes because if recompression is needed, it necessarily must be accomplished by returning the diver to the water. If symptoms of compressed-air illness do not appear within 20 minutes, the suit may be removed with reasonable assurance that no serious attack of "bends" will develop.

In no case shall surface decompression be resorted to in dives made from diving launches. The efficiency of surface decompression depends upon the immediate recompression of the diver. The time required to transfer the diver from the scene of the diving operation and from the diving launch to the deck of an attendant ship or to shore where a recompression chamber may be available is too great for surface decompression without extreme hazard. All ascents (except emergency ascents) from dives made from diving launches shall be with regular decompression.

## CHAPTER XV

### DIVING WITH THE HELMET ONLY AND SHALLOW-WATER DIVING

In the past, it has sometimes been the practice for divers when diving in warm waters to dispense with the diving dress, weighted belt, and shoes and use the standard diving helmet only. This method of diving has been commonly known as "helmet" diving and has usually been conducted from a boat or platform in the following manner.

"Helmet" diving.

The helmet is secured to the breastplate of the No. 1 or No. 2 diving outfits and additional weights are secured to the studs on the breastplate to prevent the lifting of the helmet off of the shoulders. A safety valve in the "gooseneck" connection on the helmet is tested and the air hose is connected. A bight of the hose is fixed to the left eye on the front of the breastplate by means of a marline stop, leaving a loop of hose sufficiently large to permit the passage of the diver's left arm. A blank cap is screwed onto the telephone connection of the helmet. The regulating or outlet valve is closed completely. The faceplate is then closed and the helmet is lowered into the water in an upright position and submerged below the exhaust valve. The pump is then started and the exhaust valve tested for leaks. The descending line and weight and the diving ladder are put over the side. When ready, the pump is started or air turned on from compressed-air banks, and the helmet is lowered in an upright position just below the surface. The diver descends on the diving ladder and ducks his head under and into the helmet, at the same time thrusting his left arm through the loop of air hose. When descending he holds down the left edge of the breastplate with the left hand and with the right-hand grips the descending line.

For deep diving work, this method of diving is dangerous. During the descent, helmet divers experience considerable difficulty in maintaining their equilibrium due to the weight of the diving helmet and to the buoyancy of the lower part of the diver's body. Also, in the diving helmets of the No. 1 and No. 2 outfit used without the diving dresses, the water level is approximately at the level of a diver's chin, even though the exhaust valve and telephone connections have been safely capped to prevent leakage. The diver must, therefore, remain practically upright. The regulating or outlet valve must be airtight; if there is a leak equal to the volume of air supplied, the water will rise in the helmet to the highest point of opening in the valve and the diver experiences considerable difficulty in keeping his nose clear of the water. Due to the roar caused by the air entering the helmet, many divers when using the control valve will reduce

the volume of air supply to a minimum to diminish the intensity of this noise as much as possible, as it is extremely disturbing. By diminishing the air supply the carbon dioxide content in the helmet rapidly increases. Excess carbon dioxide is difficult to detect. It gradually renders breathing more difficult and causes a headache, which the average diver will attribute to overexertion rather than to the effects of excessive carbon dioxide. The percentage of carbon dioxide may assume such large proportions as to render the diver unconscious. In this condition, he loses his equilibrium, his mouth and nose fall under the water in the helmet, and he readily drowns.

It was also the practice of some divers, in this method of diving, for the diver, when his work on the bottom was completed, to throw the helmet from his head, simultaneously draw his left arm out of the loop of air hose and swim to the surface. This procedure is commonly known as "ducking the helmet." It is extremely hazardous, as the rapidity of ascent is very likely to result, if not in "bends," then in air embolism, which is more dangerous. Swimming ascents, in "helmet diving," except in direct emergency, are absolutely forbidden.

Helmet diving in deep water has no advantage over diving with the full suit other than the comfort of the diver in tropical waters. Several fatalities have occurred to naval divers as a result of attempting to dive to depths for which decompression is required, with the helmet and without the diving suit. Accordingly, any diving by this method shall be governed strictly by the instructions of Navy Department General Order 49 of May 13, 1935 which is quoted in part as follows:

"Before authorizing helmet diving the officer in charge of the work will satisfy himself that the special circumstances make this procedure particularly desirable and that no undue hazard will be incurred by the diver. Helmet diving to depths in excess of 36 feet will be considered only for experienced divers who have been recently engaged in diving. The officer in charge, prior to the lowering of the diver, shall see that the diving air hose is looped under the diver's arm and that there is no danger from this source of accidentally pulling the helmet from his head. Descents and ascents shall be made on the descending line or stage. Ascents shall be made with the helmet on and the air supply from the surface to the helmet shall be continued until the diver is on deck and the helmet removed. In all dives in excess of 36 feet, ascents shall be made in accordance with the decompression stages prescribed in the Diving Manual. Ascents from depths of 36 feet and less may be made up the ascending line or by stage hoisted from the surface at a rate not greater than 50 feet per minute. Divers should be cautioned not to hold their breath but to freely vent air from the lungs during such ascents."

If the emergency is such as to warrant descent by this method to depths requiring decompression, and the descent is so ordered by the officer in charge, the diver, in addition to having the diving hose properly looped under the arm, shall be equipped with a manila life line secured around his waist. The life line shall not

be lashed to the air hose. All manual signals shall be made via the life line and not by the air hose. If in an emergency the diver has to be hoisted to the surface, it shall be by means of the life line independently of the air hose. Under no conditions shall the helmet be lashed or otherwise fastened to the wearer's body.

Shallow water diving as covered herein means diving within the capacity of the shallow water diving pump (Morse No. XV, or equal) which has been found to be thirty-six (36 feet). This depth can be exceeded in the case of experienced divers, provided the air supply is adequate and the design of the equipment permits. As stated in General Order No. 49, this shall only be done by "experienced divers who have been recently engaged in diving."

In shallow water diving, the diver's body is exposed to the water, which precludes effective use of shallow water equipment in any but warm waters. This method of diving is especially useful in performing underwater work on propellers, levels of floating vessels, or for other work in warm waters at shallow depths. Covering the body with a layer of grease and woolen underwear will somewhat alleviate the effects of cold water.

Shallow water diving can be performed with the shallow water equipment described in Chapter V, the standard helmet converted for "helmet" diving, or with shallow water diving masks. Shallow water diving can be safely performed by non-qualified divers, to depths less than 36 feet, but they shall be good swimmers.

The shallow water diving mask has been adopted as standard equipment for shallow diving within the Navy. This equipment and method of use is described in a manual accompanying each outfit. The mask supplied is of the Victor Berge type, manufactured by the Ohio Rubber Co. Other types of shallow water masks have been designed by the various diving activities and when they have been approved by competent diving authority their use is authorized. These masks permit much more work to be performed by the divers than the old hood, since the divers can lie down, stand on their heads, etc., which with the former, the diver was limited as to the position he could assume.

Shallow water diving can, likewise, be satisfactorily performed with the standard Navy diving helmet converted as described above, for deep "helmet" diving.

The method of use of the shallow diving helmet is outlined in Chapter V, and of the face masks in manuals accompanying the outfits. All shallow water diving shall follow the precepts set forth in General Order No. 49 for helmet diving quoted, in part, above. In addition to the practices of good diving procedure as set forth in this manual, the following shall be observed:

- (1) When using the helmet, it shall not be lashed to the body.
- (2) A lifeline shall be used of suitable size (signal haliard, or 18 thread manila, is suggested).
- (3) A nonreturn valve shall be used with the face masks, or the standard helmet. If available, they should be used with the shallow water diving helmet (hood).

Shallow-water diving.

Shallow-water masks.

(4) The diver's air hose shall be so arranged that a strain on the hose will not be transmitted direct by the helmet, hood, or mask. In the case of the mask, it is strapped to belt, provided the belt is designed for quick release. In the case of the helmet or hood, it is looped under the arm.

(5) The life line and air hose shall not be strapped together. All signals shall be made on the lifeline.

(6) Decompression, as indicated in the approved decompression tables, shall always be carried out.

(7) The divers shall be warned that if through accident or necessity the mask, hood, or helmet comes off and they must surface without it, they must exhale on the way to the surface in order to avoid air embolism.

## CHAPTER XVI

### COMPRESSED AIR ILLNESS

Compressed-air illness, often called "caisson disease" or "bends," is a disease from which divers and other workers in compressed air frequently suffer as a result of inadequate decompression. In the case of divers, it is mainly due to a too sudden reduction in pressure, such as obtains on a too rapid ascent to the surface. The disease rarely occurs unless the pressure has exceeded 20 pounds (45 feet of sea water), but may occur after exposure to 45 feet or less if the time on bottom is very great, or if the diver has been working exceedingly hard. The greater the pressure and length of exposure, the more frequent and severe will attacks of the disease result, unless proper and adequate decompression is applied.

The cause of compressed-air illness is due to the excess gas which goes into solution in the blood and tissues, being liberated in the form of bubbles during or after inadequate decompression. In normal air, this gas is chiefly nitrogen. In synthetic air, it may be helium, hydrogen, or any other inert gas used as a substitute for nitrogen.

The blood passing through the lungs will take up in simple solution an amount of gas in proportion to the partial pressure of the gases in the alveolar air. As long as the helmet ventilation is adequate, the partial pressure of carbon dioxide in the alveolar air tends to remain constant. Therefore, with a rise of atmospheric pressure there is no increase in the amount of carbon dioxide taken up by the blood during exposure to compressed air. Even though the alveolar oxygen pressure rises, the extra amount of oxygen that is thus taken up by the blood will be used up by the tissues so that in the tissues and in the venous blood leaving the tissues, there will be very little increase in the partial pressure of oxygen. Since, however, the blood passing through the lungs becomes saturated with nitrogen in proportion to the increased partial pressure of nitrogen existing in the alveolar air, the tissues and the venous blood leaving them will become more and more saturated with nitrogen with each round of circulation. With a suddenly decreased pressure (from high to normal) it is evident that at a low pressure the nitrogen in solution will be liberated, and like the gas in a soda-water bottle, form bubbles; in the case of the diver, however, they are formed much more slowly, and may take some time to increase in size sufficient to cause symptoms. The formation of these bubbles in compressed-air illness may be considered due to the partial pressure of nitrogen dissolved in the tissues and blood being too much in excess of the external pressure. Bubble formation produces local or general blockage of

Caisson disease.

Cause.

the circulation or excess pressure on nerves, with the resultant distress which in the majority of cases can be alleviated only by proper recompression and adequate decompression.

**Symptoms.**

Symptoms of compressed-air illness will usually come on a few minutes after an inadequate decompression, as a rule in the first hour. Cases have, however, been known to be delayed 15 hours or longer before the onset.

As compressed-air illness is the result of liberation of nitrogen bubbles in the various tissues of the body, it is evident that symptoms will depend on the amount of gas liberated and the places of lodgment. The depth of the original dive, the length of exposure, the rate of ascent, and the method and time of decompression are contributing factors.

The formation of gas bubbles in the small blood vessels of the skin and the subcutaneous tissues causes itching and burning sensations and a mottled skin rash. Their formation in the tendons, fascia, bone, muscles and nerve endings causes mild symptoms evidenced by pain in the muscles, bones, joints, etc. Vertigo and Meniere's symptoms complex, i. e., deafness, vertigo and vomiting, are caused by the liberation of gas in the internal ear. Embolism and formation of gas bubbles in the spinal cord cause paraplegia and its concomitant symptoms. Emboli of the cerebral vessels cause monoplegia, hemiplegia, aphasia, sensory paralytic symptoms, etc. The most serious cases are those presenting signs of asphyxia due to gas bubbles in the lung capillaries and right side of the heart. Since the air being breathed is already four-fifths nitrogen, these bubbles have no great tendency to diffuse and mix with the air in the lung.

In an analysis of more than 3,500 cases of compressed-air illness, the following classification was made:

	<i>Percent</i>
1. Cases showing pain in the various parts of the body.....	88.78
2. Cases with pain, also having local manifestations.....	.26
3. Cases with pain and prostration.....	1.26
4. Cases showing symptoms referable to the central nervous system:	
(a) Brain.....	.11
(b) Spinal cord:	
(1) Sensory disturbances, (2) motor disturbances, (3) sensory and motor disturbances....	2.16
5. Cases showing vertigo (staggers).....	5.33
6. Cases showing dyspnea and sense of constriction in chest.....	1.62
7. Cases showing partial or complete unconsciousness.....	.46

Fatal cases, of which there were 20 in number, occurred in those cases under 3, 4, and 7.

**Prevention.**

The prevention of compressed-air illness is by:

(a) Careful selection of personnel in accordance with the standards prescribed in Chapter II, Physical Qualifications of Divers.

(b) Careful examination of divers prior to every dive, with special questioning as to activity for the previous 24 hours to determine that there is no history of alcoholism, colds, or constipa-

tion, and that his general physical condition qualifies him for diving.

(c) Restriction of time of dive to come within the optimum time limits for stage decompression, and the exposure for surface decompression (as listed in the tables in ch. XIV, The Ascent).

(d) The use of proper decompression tables for the depth and time of exposure of the dive. (Ch. XIV, The Ascent.)

(e) Permitting only the *minimum* time on bottom when the nature of the diving operation demands excessive physical exertion.

(f) Avoidance of too rapid ascent to the first stop, i. e., restricting it to 25 feet per minute.

Careful compliance with the above rules will materially contribute to the prevention of bends. It must be understood, however, that there is no panacea for this disease. Regardless of precautions taken, compressed air illness will occur in an incidence of 5 percent. The only remedy is recompression, followed by adequate decompression, supplemented as necessary by the substitution of synthetic atmosphere for normal air for breathing purposes.

**Treatment.**

When any symptoms develop which are diagnosed as compressed-air illness, the diver must be immediately placed in the recompression chamber and recompressed. The prime requirement in treatment is the rapid restoration of normal blood supply by compression and absorption of the obstructing gas emboli. The pressure should be raised to a level which is 15 pounds in excess of the pressure at which definite relief from the symptoms is afforded, and maintained at that pressure for 30 minutes. United States Navy experience has proved that any less recompression pressure will often result in a recurrence of symptoms during decompression, thus requiring further recompression with resultant repetition of pressure exposure. The promptness with which pressure is applied has a definite bearing on the effectiveness of treatment. Every effort should be made to avoid delay. Divers should be instructed to report any symptoms immediately. Divers should also be required to remain near the recompression chamber for 1 hour following the completion of a dive. Also they should not remove themselves more than 1 hour's travel time for 12 hours following a dive.

Relief occurs in about 98 percent of cases with less than 75 pounds pressure. If 75 pounds affords none or incomplete relief (2%), resort should be made to the following procedures, in the order listed:

1. Additional pressure.
2. Overstay the 30-minute period on air up to 2 hours.
3. Substitute 40 percent oxygen, 60 percent air mixture as breathing medium up to 2½ hours at 75 pounds.
4. Substitute 40 percent oxygen, 60 percent helium mixture as breathing medium up to 2½ hours at 75 pounds.

If the mixtures indicated in 3 and 4 are not available, resort must be made to measure 2 although the latter is not the measure of choice, as the breathing mixtures are more efficacious, and should be used if possible.

In applying additional pressure beyond 75 pounds, apply in units of 15 pounds, being especially careful to note the point of relief, so that 15 pounds additional may be added and this pressure maintained for 30 minutes. Since above 75 pounds, each 15 pounds decreases the bubble size only about 1 percent, little benefit is obtained beyond 105 pounds. If additional pressure is to be of any avail, it is usually evident immediately. Lacking this immediate evidence, return should be effected to the 75-pound level and resort made to measures 2, 3, or 4.

On air 75 pounds pressure may be maintained 2 hours or longer. If any relief is afforded by remaining at 75 pounds, there is sufficient warranty for maintaining this pressure as long as relief is progressive and continuous. The only danger of a prolonged stay at 75 pounds is oxygen poisoning and this is a lesser evil than the return of the original or graver symptoms that will occur if decompression is started before relief is complete. If 75 pounds is maintained for more than 2 hours and complete relief occurs, there is no point in further risking oxygen poisoning by delaying the start of decompression 30 minutes from the time of relief as is done when relief occurs immediately. If complete relief is not assured, one might cautiously delay 5-10 minutes longer to insure complete relief, provided no symptoms of O<sub>2</sub> toxicity have occurred. It is useless to prolong the 75 pounds pressure when relief ceases to be progressive or if no relief has occurred in 2 hours.

Use of the indicated mixtures greatly facilitates the treatment the helium oxygen being the more effective of the two, as it reduces the nitrogen partial pressure more completely. Utilization of these mixtures at this point in treatment of usual cases must not be confused with the use of oxygen to terminate the average case as will be described later. Either mixture may speed any relief already evident to completion or may effect relief where none has occurred. They should be immediately instituted when additional pressure fails and the return to the 75-pound level is made, provided, of course, they are available.

An ordinary open circuit mask or inhalator may be used to administer the mixtures. As in the case of air, so long as relief is progressive the maximum period of 2½ hours may be exceeded and likewise decompression need not be delayed beyond the time of complete relief. In both mixtures the oxygen percentage has been increased to 40%—a 20% increase over the amount usually found in air. This fact may increase the likelihood of O<sub>2</sub> poisoning, but it has been shown to be feasible and safe for 2½ hours by a number of tests. Some individuals have tolerated these mixtures for 3 hours at 75 p. s. i. The benefits derived from the reduced partial pressure of nitrogen greatly outweigh the risk of oxygen poisoning. (5-10 minutes of air breathing at the end of each 2 hours on either mixture greatly precludes the chance of oxygen poisoning.)

If additional pressure and use of the mixtures fail to effect any relief, or if relief proceeds to a certain point and then remains stationary, it probably is indicative of permanent damage to some structure caused by the bubble although the latter is no

longer present; however, it requires prudent medical judgment to determine this fact.

In the ordinary case that has been relieved by less than 75 pounds pressure it is only necessary to provide adequate decompression to complete the treatment, after maintaining the pressure for 30 minutes.

Decompression shall be conducted in accordance with the following treatment tables.

*Air treatment table*  
[Fig. 1]

Recompression up to—	140 ft.	130 ft.	120 ft.	110 ft.	100 ft.	90 ft.	80 ft.	70 ft.	60 ft.	50 ft.	40 ft.	30 ft.	20 ft.	10 ft.
100 feet.....											14	42	52	68
150 feet.....						7	22	24	26	30	35	42	52	68
200 feet.....				13	18	19	22	24	26	30	35	42	52	68
250 feet.....				16	18	19	22	24	26	30	35	42	52	68
300 feet.....	4	14	16	16	18	19	22	24	26	30	35	42	52	68

NOTE.—The rate of ascent between stops (reduction of pressure between stops) should not exceed 25 feet per minute.

The particular table to be used depends upon the recompression pressure used, and not upon the depth of the original dive from which the compressed-air illness results.

The recompression pressures, column 1 of the above table, increase in increments of 50 feet. There will probably be many cases where the 15-pound excess pressure over the pressure which brings definite relief will fall between two of the prescribed decompression stops and periods. For example, if relief occurs at 130 feet, the additional 15 pounds pressure would make a total pressure equivalent to 163 feet. As this pressure is greater than 150 feet, the decompression prescribed for 150 feet in the table would probably prove inadequate, and the decompression prescribed for 200 feet should be used. In other words, where the recompression pressure used falls between any two recompression pressures listed in the table, decompression prescribed for the higher pressure should be used.

It will be noted that the 200-foot table required about 5 hours for completion on air. This time can be materially decreased by instituting 100% oxygen breathing for a period of 90 minutes, beginning at the 60-foot level. Results in a considerable number of cases seem to indicate that in addition to the time saving there is a more complete removal of the excess nitrogen resulting in more permanent cures. There is little danger of toxic oxygen effects as the time and percentage are well within the safe limits (2½ ATM. for 2½ hours). The oxygen mask is donned when the 60-foot level is reached and continued for 90 minutes. Usually the air decompression schedule proceeds on time during the 90-minute period. For example if the 150-foot table is used, oxygen breathing is started as soon as the 60-foot level is reached. After 22 minutes of O<sub>2</sub> breathing the pressure can be lowered to the 50-foot level; and after 30 more minutes to the 40-foot level; 35 minutes more completes the 40-foot stop and the pressure can be lowered to 30 feet. At the end of this time oxygen has been breathed for 87 minutes, thus after 3 minutes at the 30-foot level

the oxygen breathing period is completed, and the pressure can be slowly lowered to surface level. This ascent to the surface with the oxygen breathing continued is made slowly, requiring about 15 minutes from whatever depth the oxygen breathing period terminates. There is some experimental evidence to indicate that more nitrogen is eliminated if most of the oxygen breathing is accomplished at the 50-foot level. Also in actual treatment, equal or better results are obtained if the oxygen is instituted at the 60-foot level and when the proper time has elapsed the pressure is lowered to the 50-foot level and the remainder of the oxygen breathing carried out here. In the case of the 150-foot table 22 minutes is spent on oxygen at 60 feet and 68 minutes at 50 feet. As in the above case 15 minutes is consumed in proceeding from 50 feet to the surface with the O<sub>2</sub> mask in place.

In unusual cases such as those where additional pressure or the breathing mixtures are required to obtain relief, completion of the treatment by adequate decompression is somewhat different from the decompression of the average case described in the preceding paragraph.

To complete the treatment in unusual cases where the first named procedure has been used (i. e., additional pressure), adequate decompression is accomplished by reducing the pressure 1 lb. per minute until the level of the first stop (140 feet) is reached on the 300-foot table. Although a minimum of only 105 pounds, (236 feet) may have been used to secure relief, this longer table (300) plus the slow ascent provide a further margin of safety. The remainder of the decompression is completed on the 300-foot table until the 30-foot level is reached. After reaching 30-foot the diver is made as comfortable as possible by bedding, food, coffee, ventilation of chamber, etc. 30 feet pressure is maintained 12-24 hours. This practice of prolonged immersion in compressed air, colloquially termed "the overnight soak," has proved to be the conclusive method of terminating treatment. The patient is permitted to sleep and the bubbles have adequate time for absorption. Completion of decompression after 12-24 hours have elapsed can be made on the remainder of the 300-foot table, (52 minutes at 20 feet, 68 minutes at 10 feet).

In instances where the breathing mixtures are used to obtain relief, the decompression is accomplished in the same manner as described for additional pressure, except that the breathing mixture should not be discontinued until the 30-foot level is reached. Again, 30 feet pressure on air is maintained 12-24 hours and the remainder of the 300-foot table used to gain the surface after the 12-24 hour period.

So far, in discussing the alternative methods advocated for use when the usual methods fail, it has been assumed that complete relief will eventually occur or the remaining symptoms will be adjudged due to permanent damage. Some provision must be made for the instance where partial relief occurs and reaches a stationary point. In this case, whether or not the remaining symptoms are thought to be due to permanent damage, descent is made at a rate of 1 pound per minute to the lowest level above 30 feet where symptoms are endurable. Here the pres-

sure may be maintained 24-48 hours. If no change occurs in this period, symptoms are definitely due to permanent damage, and it is useless to continue the stay under pressure. Surfacing is accomplished on the last 2 stops of 300-foot table. Naturally, if complete relief intervenes in the 12-48 hour period, the diver may be surfaced on the remainder of the 300-foot table, whenever complete relief is apparent.

In addition to the special treatment so far discussed there are a few other types of cases that require special mention. These are the cases where unconsciousness, paralysis, or marked asphyxia are the symptoms. Although these cases may yield completely to less than 75 pounds pressure, it is probably wiser to proceed immediately to 75 pounds only, noting the approximate point of relief, to insure that 75 pounds is 15 pounds greater than the point of relief. If for example relief did not occur until 65 pounds, sufficient pressure should be added to secure 15 pounds beyond the point of relief. (65 plus 15 equals 80 pounds.) Thirty minutes maintenance of this pressure from the time of complete relief is considered sufficient. Decompression follows that previously outlined. Ascent to the first stop on the 300 foot table (140 feet) being made at the rate of 1 pound per minute. The 300-foot table schedule is maintained until the 30-foot level is reached and this latter pressure (30 feet) is continued 12-24 hours. Ascent to surface on remainder of 300-foot table.

In rare instances an average case of bends may appear to be successfully treated by the usual procedures, but with the lapse of 1-4 hours there is a return of the same or additional symptoms. In this instance pressure must be given to the point of relief plus 15 pounds and maintained for 30 minutes. Decompression on the appropriate table is carried out until the 30-foot level is gained. Maintenance of 30-foot of pressure for 12-24 hours will usually effect a permanent cure. Surface pressure is attained on the last two stops of the 300-foot table.

In case of "blow-up" or accidental rapid ascent, or any other circumstances requiring the diver to be brought immediately to the surface, even though no symptoms of compressed-air illness have developed, the diver should be immediately recompressed. If a recompression chamber is available, he should be immediately placed in it, first removing his helmet, weighted belt and shoes. The diving dress can be removed while in the chamber, and while the pressure is building up. If there are no symptoms, the pressure should be raised to 75 pounds, and he should be kept at this pressure for 30 minutes, and then decompressed in accordance with the treatment tables in this chapter. If symptoms do develop, the pressure should be raised to 15 pounds in excess of the pressure at which definite relief is obtained, or a minimum of 100 feet, and held 30 minutes and decompressed in accordance with the treatment tables. If a recompression chamber is not available, the diver should be hurried over to the descending line, and his valves adjusted by a tender. The diver is lowered to the bottom and kept for 30 minutes. At the end of this time the diver is surfaced on the treatment tables according to the depth, i. e., if diver is sent back to the bottom after a blow-up in 70 feet of water, use 100-foot table, figure 1. If bottom is 120

feet, use 150-foot table, etc. If bottom pressure does not effect relief, the only alternative is to keep diver on bottom as long as relief is progressive, or up to 2 hours with no relief, unless there is some provision for using the oxygen-air or oxygen-helium mixtures, in which case they are used as heretofore described, except that they would have to be fed through the diver's air line.

If the diver is unconscious, or his condition is such that he cannot make his own descent, his valves should be adjusted by another diver as he is lowered to the bottom.

In summary, the procedures discussed are as follows:

I. The average case (98%):

- (a) Immediate recompression to point of relief—Minimum 100 feet.
- (b) Addition of 15 pounds excess.
- (c) Maintain pressure 30 minutes.
- (d) Adequate decompression on basis of recompression pressure used. (*a* plus *b*) Air Tables.
- (e) Institute O<sub>2</sub> at 60 feet and breathe 90 minutes.
- (f) Either allow decompression to proceed on schedule or complete O<sub>2</sub> at 50 feet.
- (g) Slow ascent (15 minutes to surface)—O<sub>2</sub> breathing continued.

II. Alternate measures if 75 pounds proves partially or non-effective.

- (a) Additional pressure:
  1. Maximum 105 pounds.
  2. Additional 15 pounds excess to relief pressure and maintain 30 minutes.
  3. Ascent 1 pound per minute to first stop (140 feet) on 300 foot table.
  4. Decompression on 300 foot table to 30 feet.
  5. 12-24 hours "soak" at 30 feet.
  6. Surface on remainder 300 foot table.
  7. If additional pressure fails, return to 75 pounds and—
    - (b) 1. Maintain 75 pounds maximum 2 hours without relief or as long as relief is continuous, if mixtures in (c) are not available.
    2. With complete or stationary partial relief ascent 1 pound per minute to 140 feet
    3. Decompression on 300 foot table to lowest endurable level above 30 feet.
    4. Maintain endurable level 12-48 hours.
    5. Surface on remainder 300 foot table.
    - (c) If available use instead of (b):
      1. 40% O<sub>2</sub>—60% air.
      2. 40% O<sub>2</sub>—60% helium (better).
      3. Maintain 2½ hours with no relief or as long as relief is continuous.
      4. With complete, none, or stationary partial relief, decompression 1 pound per minute to 140 feet.
      5. 300-foot table to 30 feet or lowest comfortable level above 30 feet. Keep mask on during ascent.
      6. 12-48 hours soak.
      7. Surface on 300 foot table.

III. For unconsciousness, paralysis or marked asphyxia.

1. Immediate recompression to 75 pounds or more to 15 pounds excess point of relief.
2. Maintain 30 minutes.
3. Decompression as in II (*a*) (*b*) (*c*).
4. Use alternates II (*a*) (*b*) (*c*) if necessary.

IV. Recurrences:

1. Immediate recompression to point of relief plus 15 pounds.
2. Maintain 30 minutes.
3. Decompress on appropriate table to 30 feet—(figure 1).
4. 12-24 hours soak at 30 feet.
5. Surface on remainder of table (20 and 10 foot stops).

V. Blow-ups.

(a) Without symptoms:

1. Immediate recompression to 75 pounds, maintain 30 minutes.
2. Decompress on appropriate table (figure 1).
3. O<sub>2</sub> decompression from 60 feet (90 minutes).
4. Slow ascent (15 minutes) to surface.

(b) With symptoms:

1. Immediate recompression to point of relief plus 15 pounds.
2. Maintain 30 minutes.
3. Decompression on appropriate table (figure 1).
4. Institute O<sub>2</sub> at 60 feet. (90 minutes).
5. Slow ascent to surface (15 minutes).

(c) If no chamber available:

1. Without symptoms:

1. Set valves.
2. Return to bottom, stay 30 minutes. (Do not exceed 165 feet.)
3. Decompress on appropriate table (figure 1).

2. With symptoms:

1. Set valves—return to bottom for 30 minutes. (Do not exceed 165 feet.)
2. If complete relief, decompress on proper table (figure 1).
3. If no relief at bottom pressure, stay up to 2 hours, decompress approximately 1 pound per minute to lowest comfortable level above 30 feet and keep as long as possible. Surface on remainder of 300-foot table (20- and 10-foot stops).
4. If partial relief at bottom pressure—stay as long as relief is progressive. Decompress approximately 1 pound per minute to lowest endurable level about 30 feet and maintain as long as possible. Surface on rest of 300-foot table (20 and 10 foot stops).

Adjuncts in treatment are the judicious injection of glucose and saline solutions, or plasma in the severely injured patients in order to counteract the effect of hemoconcentration. The use of adrenaline and the application of warmth are additional measures if the shock syndrome is present.

The position of the patient's body should be recumbent since the site of bubble accumulation is influenced by gravity.

At the present time, submarine rescue vessels, some of the submarine tenders, and the Naval Torpedo Station, Keyport, Wash., the Submarine Base, New London, Conn., the Submarine Base, Pearl Harbor, and others are provided with standard decompression chambers such as shown and described in chapter XIX.

Where decompression chambers are available, they and their supplementary equipment listed below should be tested daily, especially if diving operations are in progress. Within the chamber should be the following equipment:

(a) A Navy type inhalator, fitted with proper facepiece, with hose line to oxygen connection in the chamber.

(b) A standard oxygen cylinder charged with pure oxygen for breathing purposes for installation outside of the chamber with necessary piping to the exterior oxygen connection on the recompression chamber.

(c) Necessary charged helium and oxygen cylinders, and supplementary piping and arrangements, for administering oxygen-helium mixtures to the diver through the oxygen inhalator referred to above.

(d) A small mattress and blankets.

(e) A container for hot water and towels for use in hot applications.

(f) A sterile syringe and needles and a fresh bottle of 1-1,000 adrenalin, a stethoscope, a blood-pressure apparatus, and a stop watch.

(g) A copy of decompression and treatment tables.

(h) A cassion gage in the man and medical locks of the chamber.

The equipment listed under item (f) is usually available in the Medical Department aboard ship. It need not actually be stowed or maintained in the chamber, but should be made available in the chamber prior to the entrance of the patient.

## CHAPTER XVII

### DIVING ACCIDENTS

Accidents which may occur during diving operations are listed alphabetically as follows: **Accidents.**

- (a) Air embolism.
- (b) Asphyxia.
- (c) Bleeding from nose and lungs.
- (d) Blowing up.
- (e) Compressed-air illness (Caisson disease).
- (f) Drowning.
- (g) Ear pains (bleeding from the ears).
- (h) Exhaustion.
- (i) Fouling.
- (j) Mechanical injuries from external violence.
- (k) Oxygen poisoning.
- (l) Squeeze.

**NOTE.** In accidents occurring in deep water, it must be remembered that while the diver can be brought up immediately to the first stop or stage of decompression, he cannot be brought immediately to the surface without danger of serious compressed-air illness unless a recompression chamber is available, and the depth and time of exposure are not greater than those prescribed as safe for surface decompression. (See Ch. XIV.)

The term "air embolism" as used in this connection refers to the entrance of air bubbles into the left side of the heart and the general circulation as a result of air being forced into the small blood vessels of the lungs due to a sudden excess of air pressure in the lung space as compared to the air pressure in the surrounding medium. The excess pressure in the body which can be withstood by the average individual over the pressure of the surrounding medium is only about  $\frac{1}{2}$  pound per square inch. Such pressures can be rapidly and greatly exceeded by a too fast ascent in water or too rapid a reduction of air pressure in the recompression chamber, or by inadvertently "holding the breath" while pressure is being reduced. Under such conditions the reduction in the internal pressure in the body by even forced expiration is less than the decreasing pressures of the surrounding medium. It is primarily for this reason that in Navy diving work rapid ascents up the descending line, or by stage or in helmet diving, "ducking" the helmet and swimming to the surface are prohibited. Internal pressures in excess of the pressure of the surrounding water are dangerous. Only a slight excess over 3 pounds per square inch may rupture the lung capillaries while higher pressures may result in unconsciousness and paralysis and possibly death.

**Air embolism.**

**Asphyxia.**

Asphyxia or suffocation of the diver may occur due to: (1) deficiency of oxygen due to bad air supply or stoppage of air supply, (2) increase of carbon dioxide due to improper ventilation of the helmet or to carbon dioxide and carbon monoxide in the diving air as a result of flashing in air compressor cylinders of lubricating oil, etc., and (3) pressure on the diver's chest from improper inflation of the suit interfering with the diver's respiration. Oxygen deficiency will seldom occur unless there is a complete stoppage of the air supply caused by failure of the pump or break in the air line. Oxygen deficiency seldom evidences itself by warning symptoms before unconsciousness occurs.

Carbon dioxide (CO<sub>2</sub>) and carbon monoxide (CO), from oil flashing in compressor or pump cylinders, will rarely be encountered, especially if precautions are observed in using good oil of high flashing point for lubrication. Carbon dioxide excess in the diver's air will usually be due to inadequate ventilation of the helmet. Such excess of CO<sub>2</sub> is readily recognized by sweating of the faceplate and the subjective symptoms of increased respiration, sweating, headache, and a general feeling of discomfort. These symptoms occur long before unconsciousness, and death does not follow for some time. In case of a short or bad air supply, the diver should remain perfectly quiet, operate his regulating exhaust valve, inflate his suit and be prepared to ascend. The tenders should be able to detect inadequate ventilation of the diver's helmet by the decrease in the number of air bubbles coming to the surface and the decreased audibility, over the telephone, of the diver's air escaping from the helmet through the air-regulating exhaust valve. Special consideration should be given to the possibility of the diver being in distress from these symptoms if he ceases to answer his telephone or signal after calling for more air.

Asphyxia from squeeze is caused by improper inflation of the diving dress. This occurs, except in a case of an accident, only to inexperienced divers who are not using a sufficient amount of air to prevent the diving dress from squeezing their chests so as to prevent adequate movement. Divers should learn to remedy this fault long before they are allowed to dive to any appreciable depth.

If asphyxia is suspected by the tender, the diver should be started immediately toward the surface. If the depth and time of exposure are not greater than those prescribed for Surface Decompression (ch. XIV), he may be brought directly to the surface (at a rate not in excess of 25 feet per minute) and placed in the recompression chamber. If not within such limits, the diver should be brought to the first stop governing stage decompression for the depth of the dive and further attempts made to communicate with him. If there is still no response, the diver should then be brought to the surface (at a rate not in excess of 25 feet per minute) regardless of the depth and time of exposure, placed in the recompression chamber and be recompressed immediately and then decompressed. In mild cases of asphyxia this is all that is necessary but in cases where unconsciousness has occurred, artificial respiration (see Drowning)

must be resorted to. All treatment should be carried out in the recompression chamber during recompression and decompression.

The condition of a man suffering from asphyxia is usually indicated by the following symptoms:

- (a) Respiration entirely absent or as an occasional gasp.
- (b) Muscles limp or rigidly contracted.
- (c) Face blue or deep red.
- (d) Eyes, as a rule, bloodshot.
- (e) Rapid or irregular pulse or both.
- (f) Body cold and clammy.

It must be remembered that the main treatment of asphyxia is the restoration of an adequate supply of fresh air. If a recompression chamber is not available, supply the diver with air from natural sources, i. e., open the helmet face plate as soon as he surfaces, and remove the helmet and suit as quickly as possible, cutting the latter off if necessary. Administration of oxygen will hasten recovery. If the diver is unconscious, lay him on deck and use artificial respiration along with the administration of oxygen. The latter may be accomplished with an inhalator or with the Navy standard oxygen rescue breathing apparatus which is furnished with adaptors for this purpose to most vessels. On recovery from asphyxia, the diver should be closely observed for occurrence of "bends." On occurrence of the slightest symptoms, he should be sent down again in company with another diver for recompression and decompression.

Bleeding from the nose is usually caused by too strenuous efforts to clear the ears.

**Bleeding from  
nose and lungs.**

Bleeding from the lungs is usually caused by the effects of a "squeeze" or from rupture of the lung tissue incident to air embolism. It can, however, occur also as the result of great respiratory efforts when the dress is unusually flat, the air supply being deficient. Treatment is the same as for "squeeze."

Accidental "blowing up" may be injurious in various ways, as:

**Blowing up.**

(a) From any depths in excess of 7 feet (depth of water above diver's helmet when standing erect), air embolism may result. This is caused by a too rapid ascent in which the diver is unable to exhaust the air in his body in ratio with the decreasing external pressures. As the average person can withstand internal pressures of only about 3 pounds per square inch without injury to the delicate lung cells and body tissues, rapid ascents from even very shallow depths are dangerous.

(b) From any depths in excess of 36 feet, an attack of compressed-air illness may result.

(c) From any depth mechanical injury may result from striking some object such as the ship's side, etc.

(d) From the possible fall back into deep water with resulting "squeeze."

Blowing up is caused by over-inflation of the dress, by too strong a pull by the tenders, or by the drag of the tide causing the diver to lose his hold on the descending line and thus being swept to the surface.

If a recompression chamber is available, the diver should be brought aboard as quickly as possible, placed in the chamber,

and the pressure raised to 15 pounds greater than the pressure at which his symptoms are relieved. He should be held at this depth 5 minutes and then decompressed on the regular treatment schedule. In the event of a diver blowing up, recompression and decompression must of course be instituted even though no symptoms are present, in which case he is to be recompressed to 75 pounds and decompressed on the regular treatment schedule. If there are symptoms, he should be taken down to a pressure of 15 pounds over that at which relief of symptoms is obtained.

If no recompression chamber is available, his valves should be regulated for him until he can handle them and he should then be lowered as rapidly as possible (without subjecting him to a squeeze) to the depth at which he was working. He should be held at this depth 30 minutes and then decompressed on the longest decompression table listed for that depth.

A diver who has been "blown up" should never exhaust air from his helmet or dress while on the surface until he is certain his tenders have secured hold of his lines and taken in all slack and he is protected from a fall.

Compressed-air illness.

Compressed-air illness is the most frequent accident encountered during diving operations and is fully discussed in chapter XVI.

Drowning.

There are two cases on record of drowning in diving dress in which the helmet became detached from the breastplate. This accident cannot happen if the safety catch at the back of a helmet is properly turned down and the stop gap closed and pinned. Even though the dress is ruptured, water cannot enter the helmet as long as the air pressure within the helmet is maintained and the diver remains in the erect position. By simply closing the exhaust valve, air is forced down into the dress and will escape at the side of the rent. In case the dress becomes too full of water, it may be necessary to slip the weighted belt to facilitate ascent.

In case of apparent drowning the water should be allowed to drain from the mouth and trachea by lifting the diver with the hands under the abdomen so that his head hangs downward. Then artificial respiration should be applied as soon as possible. The Schaeffer prone pressure method of artificial respiration is the method of choice and should be conducted as follows:

(1) Waste no time. Lay the victim on his belly, with one arm extended overhead, the other bent at the elbow; face turned to the side and resting on the forearm so that the mouth and nose are free for breathing. Kneel, straddling the patient's hips, with your knees just below his hip bones. Place your hands on the small of his back. Fingers extended over the lower ribs. Little finger over the last rib. Finger tips just out of your sight on the sides of the chest. (See pl. 87.)

(2) *First movement*.—Make pressure while deliberately counting—one, two, three—as follows:

With arms straight, bring your weight to bear upon the patient gradually and heavily but not violently. Swing forward slowly. This movement should take three seconds. (See pl. 88.)

(3) *Second movement*.—Release the pressure suddenly by swinging back quickly to the position shown in pl. 89. Rest while deliberately counting, one, two.

Repeat these movements from 12 to 15 times a minute; pressure, 3 seconds; rest, 2 seconds; complete respiration, 5 seconds—never less than 4 seconds.

(4) Continue artificial respiration without interruption for 4 hours unless breathing is restored, or until a medical officer has declared further efforts futile. If natural breathing stops after temporary restoration, resume artificial respiration at once.

(5) Watch carefully for signs indicating the return of natural breathing. Do not block feeble respiratory efforts. Time your movements so that pressure is exerted only while the patient is breathing out. Release pressure instantly when he begins to breathe in.

(6) Keep the patient warm. Give him fresh air. Without interrupting resuscitation movements, have some one else loosen his clothing about the neck, chest, and waist.

(7) Have some one hold the tongue out if it draws back. If necessary, run a safety pin through the tongue in order to hold it. The small puncture wound thus caused will injure the tongue less than clamps or forceps which squeeze and crush it. The tongue is more likely to cause trouble in drowning cases than in other forms of asphyxia.

(8) Do not attempt to give any liquid by mouth. Ammonia may be placed near the patient's nose after determining how close it may be brought to somebody else's nose without causing irritation. Do not let bystanders shut off fresh air.

(9) Some one should smartly tap the patient's shoe heels with a stick or hatchet handle 15 or 20 times every 5 minutes until respiration has been restored.

(10) If the patient revives, do not allow him to get up or to be raised for any purpose. Keep him prone until a medical officer arrives.

(11) The prone-pressure method of artificial respiration should be applied by one who has practiced on a voluntary subject.

If the diver was apparently drowned at depths requiring decompression, he should be placed in the recompression chamber and the pressure built up to that at which he was working. Artificial respiration should then be given at that depth and decompression carried out for the longest table listed for that depth.

Get wet clothes off the patient and wrap him in blankets as soon as possible and keep him warm.

Ear pains are caused by inequalities of pressure on either side of the ear drum. Pain is usually experienced while pressure is being built up and is due to failure of the Eustachian tubes to allow air to flow through to the middle ear; thus causing an undue pressure on the outer side of the ear drum. This failure to equalize properly may be due to inexperience on the part of the diver, but usually is due to the inflammation and swelling around the tube associated with a head cold or sore throat.

Ear pains.

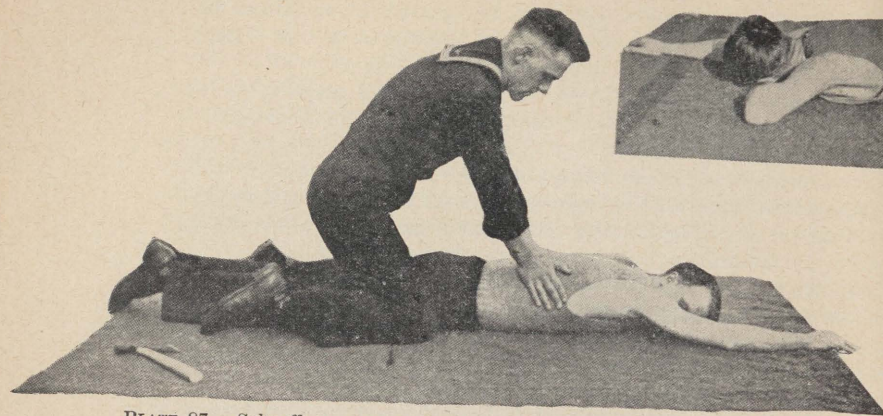

PLATE 87.—Schaeffer prone pressure method of artificial respiration.

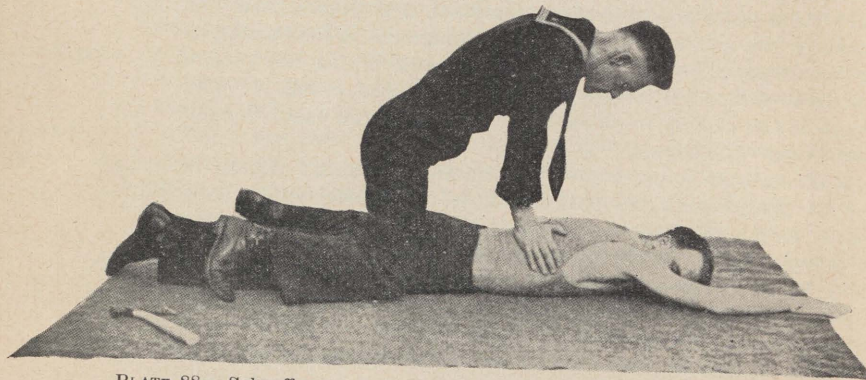

PLATE 88.—Schaeffer prone pressure method of artificial respiration.

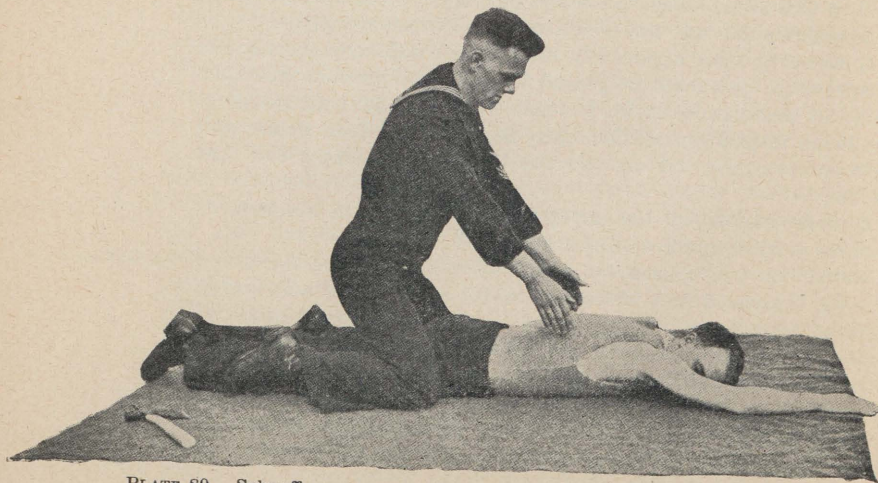

PLATE 89.—Schaeffer prone pressure method of artificial respiration.

Pressure may be sufficient to cause rupture of the drum with bleeding from the ear, or by nose bleed as a result of too strenuous effort to clear the ears. If this occurs or if the pain has been severe, the diver shall report to the medical officer for examination.

Exhaustion occurs when working under compressed air much more readily than when working at atmospheric pressure and due allowance for this should be made in planning the work the diver is to do.

Fouling is caused by the diver's lines and hose becoming entangled with some obstruction under water which prevents him from ascending. It usually requires the services of another diver to clear the one fouled. If his lines are fouled with the descending line, it may be necessary to haul up the descending line with the diver. Great care must be exercised in bringing both the diver and the descending line up at the same rate. Divers should be warned of the dangers from fouling. When a diver has become fouled and unable to ascend, death has resulted from shock and exhaustion. Also, prolonged exposure at deep depths predispose to development of pneumonia.

There are many varieties of mechanical injuries from external violence and they call for no special comment. The diver should be brought to the surface as soon as deemed safe, first aid applied as indicated, and the medical officer notified.

Normal atmosphere consists of approximately 20 percent oxygen and 80 percent nitrogen by volume. Hence at atmospheric pressure, the oxygen in normal air exerts  $\frac{1}{5}$  of an atmosphere pressure. Normal air at 10 atmospheres pressure, therefore, would exert 2 atmospheres oxygen pressure. Likewise, normal air at 15 and 20 atmospheres pressure would exert 3 and 4 atmospheres oxygen pressure, respectively.

Oxygen pressures up to 100 percent (pure oxygen at atmospheric pressure) are relatively harmless. Oxygen is toxic at the higher pressures. It has been found that even at atmospheric pressure, healthy men between the age of 20 and 40 years are able to breathe 90 percent oxygen for periods not in excess of 7 hours. At certain increased pressures and on prolonged breathing of it at atmospheric pressure, oxygen is irritating to the lungs, producing "wet lung" and a form of pneumonia. At a pressure of 4 atmospheres severe convulsive seizures are observed after about 45 minutes of pure oxygen inhalation. The first indications of toxic effect are flushing of the face, nausea, and a sense of excitement or irritability. Contraction of the visual fields, blindness, unconsciousness, and convulsions ensue when pure oxygen under 2 or more atmospheres is breathed for a long enough time.

There is some evidence to indicate that slight increases of carbon dioxide such as may be present as an impurity in the air or oxygen supply or from failure of removal of exhaled  $\text{CO}_2$ , rapidly enough from the diving dress or excess of  $\text{CO}_2$ , due to overexertion on the part of the diver increase the likelihood of "oxygen poisoning."

The maximum pressures and the time with which pure oxygen may be breathed at such pressures without detriment is not definitely known and written authority on this point is not only conflicting but at variance with the Navy's findings on the sub-

Exhaustion.

Fouling.

Mechanical injuries.

Oxygen poisoning.

ject. Extensive animal and human experimental work by the Experimental Diving Unit has definitely indicated that 2.5 atmospheres (250 percent) of oxygen can be breathed without detriment for a period of 1½ hours with 3 hours as a possible maximum limit. Considerable experimental work remains to be done to determine definitely the maximum time oxygen at lower and higher pressures than 2.5 atmospheres may be breathed without harm. Until such findings have been concluded, it is safe to accept the consensus of existing authority that the breathing of pure oxygen of from 300 to 400 percent or above, depending on the time breathed, may cause irritation of the lungs, produce congestion, exudation, hemorrhage, and pneumonia with the possibility of convulsions and death; also that the breathing of pure oxygen between 100 and 300 percent when breathed for periods of time over 6 hours may cause pulmonary involvement sufficient in extreme cases to cause death without the occurrence of convulsions. It should be remembered, however, that when introducing oxygen in any breathing system, that system initially contains 80 percent nitrogen by volume, and that the oxygen introduced is diluted accordingly.

Squeeze.

Squeeze is usually the result of an accidental fall. This has already been explained under the following:

(a) A diver descending ahead of his air supply, i. e., descending before the pressure within the dress is equal to the water pressure without.

(b) Ruptured hose and a leaky safety valve.

(c) Ruptured cuff of the dress and the diver raising his arm as when trying to reach the air regulating exhaust valve. Squeeze in this case is slight, but enough to interfere with respiration.

In cases of slight squeeze, the diving dress is flat and thus increased pressure is exerted on the chest because the air within the air passages is at a relatively lower pressure than the pressure without. The diver thus is forced to breathe against this extra pressure. The lungs only work comfortably when the external and internal lung pressure is approximately the same. A small additional external pressure materially increases the labor of breathing and respiratory embarrassment results in a short while. Often a diver struggling up his descending line (buoyancy negative) under these conditions may bleed considerably from the lungs and nose. Hemorrhage, in this case, is usually due to the rupture of small lung capillaries.

The injury is usually serious, and as such demands the immediate assistance of a medical officer. Get the diver to the surface as soon as is deemed safe (see Ch. XIV, The Ascent), remove the dress as gently as possible, and keeping the patient in the recumbent position, place him in the recompression chamber at once. Raise the pressure slowly until he shows signs of improvement or recovers consciousness. He should be given oxygen to breathe at pressure of 30 pounds or less. As patient will usually be unconscious and bleeding profusely from nose and mouth, he should be kept quiet and warm, and given stimulants together with other palliative treatment as may be necessary.

Squeeze can cause almost immediate death and extreme cases have been known where the diver has been molded into the helmet, so that it was practically impossible to remove it. Because of the seriousness of this accident, tenders must always observe the utmost caution to protect the diver from falling. The life line and air hose should never be permitted to slip through the hands by the run. If for any reason the diver finds himself in danger of falling, he should signal for more air, or open wide his air-control valve, throttle the regulating escape valve, and notify the surface to "Hold on." The moment the danger is over, reregulate the air to prevent "blowing up."

NOTE.—The effects of squeeze are much more serious than those of "blowing up." Avoid both, but if it is a matter of two evils, choose the latter.

## CHAPTER XVIII

## DEEPER DIVING BY USE OF OXYGEN-HELIUM MIXTURES

## SECTION I. HISTORY

Introduction of helium as a substitute for nitrogen.

The Navy has continually sought new ways and means of enabling divers to descend to deeper depths with safety. As far back as 1921, it was suggested that the replacement of nitrogen in the normal air supplied to divers with a lighter gas might achieve this objective. In 1925 the Bureau of Construction and Repair began an investigation of mixing helium with oxygen as a synthetic air supply for divers, since helium is an inert, non-toxic, and nonexplosive gas. By varying the oxygen content of the mixtures, it was thought that greater depths could be obtained without oxygen poisoning. It was also thought that, since helium is more diffusible than nitrogen and less soluble in the body tissues, its use would reduce the possibility of the diver to contract bends and permit the employment of shorter decompressions.

Results of Experimental Diving Unit: Work.

Except for periods which had to be devoted to other important developments, these experiments with oxygen-helium mixtures have been carried on by the Bureau of Construction and Repair from 1925 to 1940 and by the Bureau of Ships from 1940 to the present time at the Experimental Diving Unit, Navy Yard, Washington, D. C. Contrary to previous expectations, the use of oxygen-helium mixtures does not permit material reductions in decompression time but does permit deeper diving and the performance of work at such depths with reasonable safety. Simulated depths of 500 feet in diving water tanks and 440 feet in the open sea have been attained by divers using oxygen-helium mixtures as air supply. Oxygen-helium mixtures were used almost entirely by the divers in the salvage of the U. S. S. *Squalus* which sunk in about 240 feet of water.

Mental and physical reaction to breathing oxy-helium mixtures.

During the years of experimentation with the use of these oxygen-helium mixtures, a great many tests have been made. Most of the results have conformed with preconceived theories. Some have been contrary to certain recognized principles of decompression and introduce a field for further investigation. In general, as a result of this work it can be stated that:

- (a) The breathing of helium when mixed with the proper amount of oxygen is harmless.
- (b) Helium is absorbed and given off more rapidly in solution in the body tissues, than is nitrogen.
- (c) Some tissues will not absorb as large amount of helium as they will nitrogen. For example fat tissue will contain about seven times more nitrogen than lean muscle tissue but only about three times more helium.

(d) As helium is absorbed more rapidly than nitrogen, some tissues may take up more helium during a given exposure to pressure. Helium will also leave the tissues faster. Both phases promote the formation of bubbles which can cause bends. While the ratio of the pressure of the gas within the diver's body to the external pressure can be 2.0 or 2.25 to 1 safely with nitrogen, this ratio is about 1.7 to 1 with helium. Therefore, this lower safe ratio of pressures with helium requires the first decompression stop to be deeper than with nitrogen. Accordingly it is desired to emphasize that a diver can contract bends when using oxygen-helium mixtures as readily as with normal air and that decompression in accordance with the tables herein is essential.

(e) Oxygen and helium must be mixed in proper proportions to suit the depth of the particular dive involved. The oxygen and helium should be obtained in separate cylinders and mixed on board as required. Oxygen concentration must be kept within the safe limits of about 2½ atmospheres absolute pressure of pure oxygen. During decompression, the diver can be shifted to pure oxygen at 60 feet to hasten helium elimination from his body.

(f) Apparently divers are more mentally alert when breathing oxygen-helium mixtures under pressure than when breathing normal air. The sense of depth commonly experienced when breathing the latter is much reduced. Also they work considerably harder and for longer periods, although this latter condition may be due to some extent to the better ventilation of the helmet with its resultant improved oxygen supply and decrease of carbon dioxide.

(g) The advantages of using oxygen-helium mixtures in lieu of normal air are applicable mainly to diving in depths in excess of 150 feet. For the shallower depths, the time saved in decompression and improved physiological reactions are not commensurate with the elaborate special equipment which has to be provided. Consequently, this equipment is furnished only to submarine rescue vessels and to such submarine tenders that have facilities for carrying out deep submarine rescue and salvage operations.

Restrictions on use.

(h) Helium conducts heat much more rapidly than air. When diving with oxygen-helium mixtures, the heat is transferred from the diver's body so rapidly that special provisions must be made to keep him from becoming chilled. Specially designed electrically heated underwear developed for this purpose contributes to his comfort when worn in water of less than 60° F.

Protection against chill.

(i) When using oxygen-helium mixtures for diving, it is necessary that an adequate recirculating system be provided in order to recover and conserve the helium. An efficient purifier for removing the CO<sub>2</sub> ordinarily generated in the helmet is essential as a part of this system. In the Navy's work this is accomplished by modification of the conventional helmets.

Special helmets required for use of oxy-helium.

## SECTION II. DECOMPRESSION

The characteristics of decompression with oxygen-helium mixtures are different from those of air. With the former a larger volume of gas is concentrated in the faster saturating parts of the

Difference in oxy-helium tables and compressed air tables.

body, and the rapid diffusion of gas from one part of the body to another on reduction of pressure requires the keeping of the body at high pressures for a longer time during the primary period of decompression. Also the normal procedure for decompression after an oxygen-helium dive is to have the diver breathe pure oxygen beginning at the 60-foot stop. Since pure oxygen should not be used at depths greater than 60 feet, the decompression must be made on oxygen-helium mixtures up to that point. In case of necessity, however, the diver can be decompressed on oxygen-helium mixture throughout, or shifted to compressed air, subject to separate and distinct procedure for use in these two cases. In shifting to compressed air, however, it has been found that the human body cannot stand a direct change from helium to nitrogen at depths beyond 6 atmospheres' pressure without discomfort unless the air is supplied gradually at an increase in volume of about 3 percent per minute. In actual practice gradual shift from helium to air is accomplished through use of the recirculation system for 20 minutes of decompression time. The oxygen-helium decompression tables which follow are accordingly different from those used for ordinary compressed air diving. The tables are somewhat complicated but at this time further simplification has been impracticable due to the many factors and conditions affecting the decompression.

To prevent initial formation of bubbles in the diver's body under different conditions of exposure to helium under pressure, the proper rate of ascent must be observed up to the first decompression stop. The rate of ascent varies with the depth of the dive and its duration. The approved procedure for decompression with oxygen-helium mixtures is as follows:

(a) Take percentage of oxygen breathed by divers and the depth. Based on these factors obtain proper rate of ascent from table I.

(b) Take depth of dive and percentage of oxygen used by diver. Based on these factors find from table II the partial pressure of helium in tissues most completely saturated.

(c) Take time of dive from beginning of descent to beginning of ascent.

(d) With partial pressure obtained from table II and time of dive find depth and time for decompression stops in table III.

(e) Bring diver to first stop at rate of ascent prescribed in table I. When diver reaches 60-foot stop, shift him to pure oxygen and order him to "ventilate" to remove helium from his hose and dress. This will require about 25 cubic feet of pure oxygen. After ventilating, order diver to "circulate." The change in the sound of the diver's voice over the telephone due to the change in the density of the gas he is breathing is an excellent indication of the effectiveness of the ventilation. Continue the supply of pure oxygen to the end of the decompression.

In case it becomes necessary to recompress a diver for bends after he has inhaled pure oxygen during his decompression, oxygen should be administered with care. Under such conditions the diver may exhibit abnormal susceptibility to oxygen poisoning.

Use of oxygen in repeated decompression.

In deciding the oxygen concentration of the oxygen-helium mixture to be used for divers, care should be exercised to insure that the maximum concentration does not exceed 2½ atmospheres (absolute) of pure oxygen at the depths of the dive and that the minimum in all cases is sufficient to insure enough oxygen to meet the diver's requirements under all conditions of descent, work on the bottom, and ascent. A minimum of 15 percent has been the practice in training.

Maximum and minimum concentrations of oxygen.

TABLE I.—Rate of ascent in feet per minute

Depth	Oxygen percent								
	10	15	20	25	30	35	40	45	50
50	10	10	20	20	30	30	40	50	75
100	10	20	30	40	50	75	-----	-----	-----
150	10	30	40	50	75	-----	-----	-----	-----
200	10	40	50	75	-----	-----	-----	-----	-----
250	20	50	75	-----	-----	-----	-----	-----	-----
300	20	50	75	-----	-----	-----	-----	-----	-----
350	30	75	-----	-----	-----	-----	-----	-----	-----
400	30	75	-----	-----	-----	-----	-----	-----	-----
450	40	75	-----	-----	-----	-----	-----	-----	-----
500	40	75	-----	-----	-----	-----	-----	-----	-----
550	50	75	-----	-----	-----	-----	-----	-----	-----
600	50	75	-----	-----	-----	-----	-----	-----	-----

NOTE.—75 feet per minute is the maximum practical rate.

TABLE II.—Helium-oxygen—table of partial pressures—40 to 600 feet

Depth	Percentage of oxygen used												
	13	15	17	19	21	23	25	30	35	40	45	50	55
40	65	64	62	61	59	58	56	60	56				
50	74	72	71	69	68	66	64	60	56				
60	83	81	79	78	76	74	72	67	63	58	53		
70	92	90	88	86	84	82	80	75	69	64	59	54	
80	101	99	96	94	92	90	87	82	76	71	65	59	53
90	110	107	105	103	100	98	95	89	83	77	71	65	58
100	119	116	113	111	108	105	103	96	90	83	76	70	63
110	128	124	121	119	116	113	110	103	97	89	82	75	67
120	136	133	130	127	124	121	118	110	103	95	87	80	72
130	145	142	139	135	132	129	126	118	109	101	93	85	
140	154	151	147	144	140	137	133	125	116	107	99		
150	163	159	156	152	148	145	141	132	123	114	104		
160	172	168	164	160	157	153	149	139	129	120			
170	181	177	173	169	165	160	156	146	136	126			
180	190	186	181	177	173	169	164	154	143				
190	199	194	190	185	181	176	172	161	150				
200	208	203	198	194	189	184	180	168	156				
210	216	212	207	202	197	192	187	175					
220	225	220	215	210	205	200	195	183					
230	234	229	224	219	213	208	203	190					
240	243	238	232	227	222	216	211	197					
250	252	247	241	235	230	224	218						
260	261	255	249	243	237	231	225						
270	270	264	258	252	246	240	233						
280	280	273	267	260	253	247	241						
290	288	281	275	268	262	255	249						
300	297	290	283	277	270	263	257						
310	306	299	292	285	278	271							
320	314	307	300	293	286	279							
330	323	316	309	302	294	287							
340	332	325	317	310	303	295							
350	341	334	326	318	311	303							
360	350	343	335	327	319								
370	359	351	343	335	327								
380	368	359	351	343	334								
390	377	368	360	351									
400	386	377	368	359									
410	395	386	377	368									
420	403	394	385	376									
430	412	403	394	385									
440	421	412	403	385									
450	430	420	410										
460	439	429	419										
470	448	438	428										
480	457	447	437										
490	466	456	446										
500	475	465											
510	484	473											
520	493	482											
530	502	492											
540	511	500											
550	520	509											
560	529	518											
570	538	527											
580	548												
590	557												
600	566												

1. Obtain partial pressure from table II.
2. Time of dive is from time diver starts down until beginning of ascent.
3. When diver reaches 60-foot stop, or 50-foot stop when first stop is at 50 feet, shift to pure oxygen and have diver "ventilate" with 25 cubic feet of pure oxygen to remove helium from dress and hose. Finish decompression with diver breathing pure oxygen.

TABLE III.—Decompression tables

Partial pressure (feet)	Time of dive in minutes	Stops, 50 feet	Time to first stop	Total time	Partial pressure (feet)	Time of dive in minutes	Stops, 50 feet	Time to first stop	Total time
60	10	0	2	2	110	10	6	2	8
	20	0	2	2		20	21	2	23
	30	0	2	2		30	32	2	34
	40	0	2	2		40	41	2	43
	60	4	1	5		60	57	2	59
	80	7	1	8		80	69	2	71
	100	10	1	11		100	76	2	78
	120	12	1	13		120	81	2	83
	10	0	2	2		140	84	2	86
	20	5	1	6		160	85	2	87
70	30	8	1	9	180	86	2	88	
	40	10	1	11	200	87	2	89	
	60	15	1	16	10	8	2	10	
	80	21	1	22	20	27	2	29	
	100	26	1	27	30	38	2	40	
	120	29	1	30	40	48	2	50	
	140	31	1	32	60	65	2	67	
	160	32	1	33	80	78	2	80	
	10	4	1	5	100	86	2	88	
	20	9	1	10	120	91	2	93	
80	30	14	1	15	140	94	2	96	
	40	18	1	19	160	95	2	97	
	60	26	1	27	180	97	2	99	
	80	34	1	35	200	98	2	100	
	100	42	1	43	10	9	2	11	
	120	46	1	47	20	31	2	33	
	140	48	1	49	30	44	2	46	
	160	49	1	50	40	56	2	58	
	10	5	2	7	60	75	2	77	
	20	13	2	15	80	88	2	90	
90	30	19	2	21	100	95	2	97	
	40	25	2	27	120	100	2	102	
	60	36	2	38	140	103	2	105	
	80	46	2	48	160	105	2	107	
	100	55	2	57	180	106	2	108	
	120	59	2	61	200	107	2	109	
	140	61	2	63	220	108	2	110	
	160	62	2	64	10	10	2	12	
	180	63	2	65	20	34	2	36	
	10	6	2	8	30	50	2	52	
100	20	17	2	19	40	63	2	65	
	30	26	2	28	60	83	2	85	
	40	33	2	35	80	96	2	98	
	60	46	2	48	100	104	2	106	
	80	57	2	59	120	109	2	111	
	100	65	2	67	140	111	2	113	
	120	70	2	72	160	113	2	115	
	140	73	2	75	180	115	2	117	
	160	74	2	76	200	116	2	118	
	180	75	2	77	220	117	2	119	
200	76	2	78						

TABLE III.—Decompression tables—Continued

Partial pressure (feet)	Time of dive in minutes	Stops (minutes)				Time to first stop	Total time
		80 feet	70 feet	60 feet	50 feet		
150	10				10	3	13
	20				36	3	39
	30				56	3	59
	40				61	3	74
	40			10	81	3	94
	60			10	101	3	107
	80			10	94	3	107
	100			10	101	3	114
	120			10	106	3	119
	140			10	109	3	122
	160			10	111	3	124
	180			10	113	3	126
	200			10	114	3	127
	220			10	114	3	127
	240			10	115	3	128
160	10				21	3	24
	20			10	34	3	47
	30			10	54	3	67
	40			10	69	3	82
	60			10	91	3	104
	80			10	102	3	115
	100			10	108	3	121
	120			10	113	3	126
	140			10	115	3	128
	160			10	116	3	129
	180			10	117	3	130
	200			12	117	3	132
	220			14	117	3	134
	240			15	117	3	135
	170	10				16	3
20					38	3	51
30					61	3	74
40					75	3	88
60					94	3	114
80			7		106	3	126
100			7		113	3	133
120			7		117	3	137
140			7		117	3	141
160			8		117	3	144
180			10		117	3	147
200			12		117	3	148
220			13		117	3	149
240			14		117	3	150
180		10				19	3
	20				43	3	63
	30				64	3	84
	40				80	3	100
	60				101	3	121
	80		9		110	3	132
	100		9		117	3	144
	120	7	5		117	3	149
	140	7	9		117	3	152
	160	7	11		117	3	156
	180	7	14		117	3	159
	200	7	17		117	3	161
	220	7	19		117	3	163
	240	7	21		117	3	165
			23		15	3	165

TABLE III.—Decompression tables—Continued

Partial pressure, (feet)	Time of dive	Stops (minutes)						Time to first stop	Total time
		100 feet	90 feet	80 feet	70 feet	60 feet	50 feet		
160	10						7	4	42
	20						7	4	70
	30						7	4	91
	40						7	4	108
	60						7	4	129
	80						7	4	145
	100						7	4	152
	120						7	4	158
	140						7	4	163
	160						7	4	167
	180						7	4	170
	200						7	4	172
	220						7	4	174
	240						7	4	175
	200	10						7	4
20							7	4	76
30							7	4	95
40							7	4	116
60							7	4	139
80							7	4	154
100							7	4	164
120							7	4	171
140							7	4	175
160							7	4	181
180							7	4	183
200							7	4	184
220							7	4	186
240							7	4	187
210		10						7	4
	20						7	4	78
	30						7	4	103
	40						7	4	122
	60						7	4	145
	80						7	4	162
	100						7	4	171
	120						7	4	180
	140						7	4	184
	160						7	4	187
	180						7	4	190
	200						7	4	192
	220						7	4	194
	240						7	4	196
	220	10						7	4
20							7	4	84
30							7	4	111
40							7	4	131
60							7	4	155
80							7	4	170
100							7	4	180
120							7	4	192
140							7	4	195
160							7	4	199
180							7	4	201
200							7	4	202
220							7	4	204
240							7	4	207

TABLE III.—Decompression tables—Continued

Partial pressure (feet)	Time of dive	Stops (minutes)									Time to first stop	Total time		
		120 feet	110 feet	100 feet	90 feet	80 feet	70 feet	60 feet	50 feet					
230	10					7	0	10	31		4	52		
	20					7	0	3	10	66	4	90		
	30					7	2	4	10	87	4	116		
	40						0	6	9	10	102	4	138	
	60			7			4	9	12	11	114	4	161	
	80			7			8	12	17	14	117	4	183	
	100			7			12	15	20	15	117	4	194	
	120			8			14	19	23	15	117	4	204	
	140			10			16	20	23	15	117	4	209	
	160		7	6			18	20	23	15	117	4	214	
	180		7	7			19	20	23	15	117	4	216	
	200		7	9			19	20	23	15	117	4	218	
220		7	11			19	20	23	15	117	4	220		
240		7	13			19	20	23	15	117	4	222		
10						7	0	10	35		4	56		
20				7		0	1	4	10	71	4	97		
30				7		0	5	7	10	90	4	123		
40				7		0	3	7	9	10	103	4	143	
60			7			0	8	10	14	11	115	4	169	
80			7			3	10	14	18	14	117	4	187	
100			7			6	12	17	23	15	117	4	201	
120			7			7	16	19	23	15	117	4	208	
140			7			11	16	20	23	15	117	4	213	
160			7			13	19	20	23	15	117	4	218	
180			8			15	19	20	23	15	117	4	221	
200			8			17	19	20	23	15	117	4	223	
220			9			17	19	20	23	15	117	4	224	
240			11			17	19	20	23	15	117	4	226	
10						7	0	10	38		4	60		
20						7	0	1	6	10	73	4	101	
30						7	0	4	6	10	95	4	132	
40						7	0	5	8	9	10	106	4	149
60						7	4	8	11	14	12	117	4	177
80						7	7	11	16	18	15	117	4	195
100						7	10	14	19	23	15	117	4	209
120		7				3	12	17	19	23	15	117	4	217
140		7				4	15	18	19	23	15	117	4	222
160		7				7	16	19	19	23	15	117	4	227
180		7				9	17	19	20	23	15	117	4	231
200		7				11	17	19	20	23	15	117	4	233
220		7				12	17	19	20	23	15	117	4	234
240		7				13	17	19	20	23	15	117	4	235
10						7	0	2	10	41		4	64	
20						7	0	3	7	10	77	4	105	
30						7	0	4	6	8	10	97	4	136
40						7	2	5	9	9	10	109	4	155
60						7	7	9	12	16	13	116	4	184
80						7	9	13	15	21	15	117	4	204
100						7	11	14	19	23	15	117	4	216
120						7	13	19	20	23	15	117	4	226
140						7	15	19	20	23	15	117	4	231
160						8	17	19	20	23	15	117	4	236
180						9	17	19	20	23	15	117	4	238
200						10	17	19	20	23	15	117	4	241
220						11	17	19	20	23	15	117	4	242
240						13	17	19	20	23	15	117	4	244

TABLE III.—Decompression tables—Continued

Partial pressure (feet)	Time of dive	Stops (minutes)										Time to first stop	Total time							
		150 feet	140 feet	130 feet	120 feet	110 feet	100 feet	90 feet	80 feet	70 feet	60 feet			50 feet						
270	10									7	0	0	4	10	44	4	70			
	20									7	0	2	4	6	10	80	4	113		
	30									7	0	2	5	6	9	10	100	4	143	
	40									7	0	3	8	9	10	10	110	4	161	
	60									7	3	7	10	14	16	13	117	4	191	
	80									7	6	10	13	17	23	15	117	4	212	
	100									7	9	13	16	20	23	15	117	4	226	
	120									7	4	11	14	19	20	23	15	117	4	234
	140									7	5	14	15	19	20	23	15	117	4	239
	160									7	7	15	17	19	20	23	15	117	4	244
	180									7	9	16	17	19	20	23	15	117	4	247
	200									7	11	16	17	19	20	23	15	117	4	249
220									7	13	16	17	19	20	23	15	117	4	251	
240									7	15	16	17	19	20	23	15	117	4	253	
10									7	0	0	1	3	10	47		4	73		
20									7	0	0	2	6	6	10	84	4	119		
30									7	0	3	6	6	9	10	104	4	149		
40									7	0	2	5	8	8	12	11	113	4	170	
60									7	0	6	8	10	14	18	14	116	4	197	
80									7	3	8	11	14	17	23	15	117	4	219	
100									7	5	11	13	16	20	23	15	117	4	231	
120									7	8	12	16	19	20	23	15	117	4	241	
140									7	10	16	17	19	20	23	15	117	4	248	
160									8	13	16	17	19	20	23	15	117	4	252	
180									9	14	16	17	19	20	23	15	117	4	254	
200									10	15	16	17	19	20	23	15	117	4	256	
220									12	15	16	17	19	20	23	15	117	4	258	
240									14	15	16	17	19	20	23	15	117	4	260	
10									7	0	0	2	3	10	49		4	76		
20									7	0	0	4	6	7	10	86	4	124		
30									7	0	1	5	5	9	10	105	4	155		
40									7	0	4	6	8	9	12	11	114	4	175	
60									7	4	6	8	12	15	18	14	117	4	205	
80									7	7	9	11	15	17	23	15	117	4	225	
100									7	9	11	15	17	20	23	15	117	4	240	
120									7	11	13	16	19	20	23	15	117	4	249	
140									7	13	16	17	19	20	23	15	117	4	256	
160									7	14	16	17	19	20	23	15	117	4	260	
180									7	15	16	17	19	20	23	15	117	4	263	
200									7	16	17	19	20	23	15	117	4	265		
220									7	17	17	19	20	23	15	117	4	266		
240									7	18	17	19	20	23	15	117	4	267		
10									7	0	0	0	3	3	10	52	5	81		
20									7	0	0	1	6	6	10	91	5	133		
30									7	0	2	5	5	9	10	106	5	158		
40									7	0	5	7	8	11	13	12	111	5	179	
60									7	6	7	9	12	15	20	15	117	5	213	
80									7	8	10	12	16	19	23	15	117	5	234	
100									7	10	12	15	19	20	23	15	117	5	248	
120									7	11	16	17	19	20	23	15	117	5	258	
140									8	9	14	16	17	19	20	23	15	117	5	263
160									8	13	15	16	17	19	20	23	15	117	5	268
180									7	13	15	16	17	19	20	23	15	117	5	270
200									7	14	15	16	17	19	20	23	15	117	5	273
220									7	15	16	17	19	20	23	15	117	5	274	
240									7	16	16	17	19	20	23	15	117	5	277	

1 Take 1 extra minute from first stop to next stop.





(d) Recompress diver in the recompression chamber to 50 feet. If the diver can clear his ears, he should start breathing oxygen on his way down; otherwise as soon as he reaches 50 feet he should start breathing oxygen. The tender should assist diver to remove the diving suit and underwear while pressure is being applied. The total elapsed time, from 50 feet in the water until the diver is at 50 feet in the chamber breathing oxygen, should not exceed 3 to 4 minutes.

(e) Keep the diver at 50 feet (on oxygen) in the recompression chamber for the time required for the 50-foot stop as given in the normal helium oxygen decompression tables.

(f) When bringing the diver out of the recompression chamber, reduce the pressure at the rate of 10 feet per minute (that is, take 5 minutes to bring him to the surface from 50 feet).

2. (a) In case the first stop in the table used is 50 feet, bring the diver to 50 feet and shift him to oxygen.

(b) After he has been breathing oxygen for 10 minutes at 50 feet, bring him to surface and carry out the same procedure for recompression as described in paragraphs 1 (c), (d), (e), and (f) above.

Recompression chamber should be equipped with oxygen supply system, and oxygen masks provided for use in the chambers.

Decompression in this manner has been successful for exposures of 1 hour at 250 feet, 20 minutes at 300 feet, and 10 minutes at 350 and 440 feet.

1. Bring diver aboard and remove helmet, belt, and shoes as quickly as possible and place in recompression chamber.

2. Recompress to point of relief of symptom (or recovery), plus 15 pounds. If no symptoms have developed, recompression to 75 pounds.

3. Maintain maximum pressure a minimum of 30 minutes after symptoms have been relieved. If no symptoms have developed maintain pressure of 75 pounds for 30 minutes.

4. Decompress according to Table V, selecting the next higher table than the actual depth (pressure) used in preceding paragraph, unless the depth (pressure) is at an even 50-foot figure as tabulated in Table V. For example, if pressure (depth) used is 175 feet, use the 200-foot table.

5. Complete the decompression from the 60-foot level (stop) by breathing pure oxygen for 90 minutes as follows:

(a) At 60 feet for time as indicated in air treatment table. (22 minutes if 150-foot table used.)

(b) At 50 feet for 68 minutes.

(c) From 50 feet to surface in 15 minutes with oxygen mask in place.

6. Surface slowly after 90 minutes oxygen breathing period, maintaining the oxygen mask until surface is reached.

### SECTION III. MIXING OXYGEN AND HELIUM

Helium for diving purposes is obtained from the Naval Air Station Lakehurst, Lakehurst, N. J., and stocked at the submarine bases at New London, Coco Solo, San Diego, and Pearl Harbor.

Decompression procedure following "blow up" by diver using helium oxygen.

Source of helium.

Impurities in helium are detrimental to proper decompression. Requisitions should bear a notation that gas must be at least 97.5 percent pure, the impurities, if any, to be nitrogen and that both gas and flask are to be free of oil or oil vapor as the gas is to be mixed with oxygen. Quality.

Oxygen is obtainable from stocks at the submarine bases at New London Conn., Coco Solo, C. Z., San Diego, Calif., and Pearl Harbor, T. H. Requisitions should bear a notation that the gas must be at least 99.44 percent pure, the impurities, if any, to be nitrogen and water vapor.

Helium fittings are made up with a left-hand thread and special fittings are utilized when using the cylinders. Because of the high pressure in the flasks when received it is desirable to "bleed" fully charged flask into empty ones before mixing the oxygen. Connect an empty helium flask to a full one (about 1,800 pounds per square inch) with the T-fitting provided with two left-hand threaded nuts. Open the stop valve on the full flask and read the pressure on the gage on the T-fitting. Open the valve on empty flask and allow the pressure to equalize. The gage reading should then be half its original value. Splitting helium flasks.

In order to add oxygen to the helium a fully charged oxygen flask is "bled" into the helium flask containing helium at the reduced pressure mentioned above. This requires a T-fitting provided at one end with a right-hand threaded nut and at the other with a left-hand threaded nut. Mixing helium and oxygen.

Using the T-fitting, connect a split helium flask (about 900 pounds per square inch) to a full oxygen flask (about 1,800 pounds per square inch). Open the stop valve on the helium flask, read the pressure on the gage on the T-connection, then close the valve again. Open the stop valve on the oxygen flask and read the gage.

Compute the pressures which each flask will contain when enough oxygen has flowed into the helium flask to give the desired percentage as follows:

Divide helium pressure in flask by percentage of helium desired in mixture. This will be pressure corresponding to 1 percent of pressure of the mixture. To find pressure in helium flask after mixing, multiply by 100. To obtain drop in pressure in oxygen flask, multiply by percentage of oxygen desired.

#### Example:

Helium flask pressure 800 pounds per square inch.

Oxygen flask pressure 1,400 pounds per square inch, 20 percent oxygen, 80 percent helium mixture desired.

$$\text{Pressure of 1\% mixture} = \frac{800}{80} = 10 \text{ lbs./sq. in.}$$

Pressure of mixture in helium flask =  $100 \times 10 = 1,000$  pounds per square inch.

Pressure drop in oxygen flask =  $20 \times 10 = 200$  pounds per square inch.

Experience has shown that if the oxygen is allowed to enter the helium flask rapidly, more accurate results are obtained.

The helium flask will heat up and the oxygen flask will become cold due to their respective pressure changes (Charles' Law).

If the flow between the two flasks is stopped under these conditions and the temperatures of the two flasks allowed to equalize again, the pressure in the oxygen flask will have increased slightly and that in the helium flask will have dropped (Charles' Law also). No way of controlling the temperature of the gases during mixing has been devised, so this temperature effect must be compensated for by running over a slight excess oxygen pressure, or by adjusting the pressures two or three times at intervals after the flasks have been allowed to return to approximately the same temperature. The technique depends entirely on judgment developed by experience.

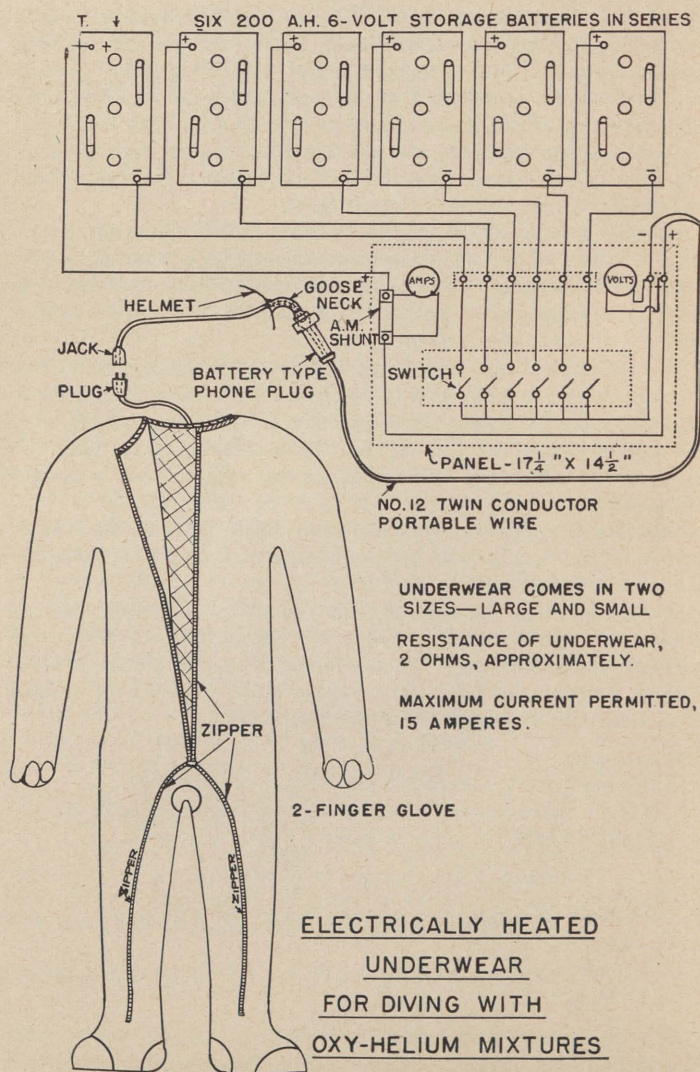

PLATE 90.—Electrically heated undergarments for diving with oxy-helium mixtures.

After the gases are mixed, they must be allowed to set for 2 or 3 days to permit the oxygen and helium to diffuse through each other. Before using the mixture, draw a sample from each flask and determine the oxygen percentage by chemical analysis. Mark each flask with chalk to show gas it contains. Serial numbers of all flasks and the analysis of the contents of each should be recorded on a form for that purpose.

Each flask of oxy-helium mixture must be checked accurately for oxygen percentage before being used. The carbon dioxide percentage is determined at the same time and is of importance to the diver. Samples of the gas are collected in the sampling bottles, the carbon dioxide measured by absorbing it in the apparatus, then the oxygen percentage determined in the same way. The remaining gas is assumed to be helium with not more than 3 to 4 percent nitrogen, provided the helium and oxygen mixed were of required purity (97.5% and 99% respectively).

Samples of air and exhaled breath may be analyzed for practice.

Flasks of oxy-helium mixture used for diving should have an oxygen content within 2 percent of the percentage desired and have not more than 0.03 percent carbon dioxide. Flasks are placed in the manifold so that the average of the flasks in each bank is as close as possible to the oxygen percentage to be used.

Helium flows through orifices faster than oxygen and will penetrate openings through which oxygen cannot pass. When the gases are mixed and are not used for some time, the proportions may change due to loss of helium. For this reason gas analysis should be made just before the mixture is to be used.

The Haldane-Henderson apparatus shown on plate 91 is very accurate and will give percentages of oxygen and carbon dioxide to within 0.01 percent in the laboratory with an experienced technician. The gas burette is calibrated to 0.001 cc. and the cost of a burette alone is equal to more than one-third of the value of the entire outfit.

For good results the apparatus should be mounted. The equipment is shipped disassembled. It should be mounted on the wooden stand as illustrated on plate 91 thus avoiding strains on glass tubing. The stand should be attached permanently to a table. The fluorescent lamp is mounted behind the panel of the stand to provide illumination through the ground glass windows in the panel. Vibration, motion of the equipment, poor lighting, temperature variations, and other inaccuracies will introduce errors in reading the scales. Attempts have not been made to use the apparatus on board ship, so the probable limits of error under such conditions are not known but they may be large.

The stirring tube may be connected to a source of compressed air instead of to the rubber bulb.

All joints should be made up glass-to-glass using sulphur-free rubber tubing. Lubricate and seal stopcocks with a minimum amount of Lubriseal. Stopcocks must be kept clean.

The carbon dioxide absorbent is potassium hydroxide (KOH), 10 percent. It must be entirely clear and free of precipitate.

The oxygen absorbent is potassium pyrogallol. It is prepared as follows:

Haldane-Henderson gas analyses apparatus.

Assembling apparatus.

Reagents.

Add 200 cc. of water to 300 grams of potassium hydroxide sticks (not purified by alcohol). Place solution in a bottle with a greased stopper. To each 100 cc. of the solution add 15 grams of pyrogallol acid (Merck).

Both reagents must be kept from contact with the air to prevent their absorbing carbon dioxide and oxygen thus losing their strength. Both are very caustic. The potassium pyrogallol should be kept in a bottle with a greased stopper.

Preparation  
for use.

Fill water jacket with water to just above enlarged portions of thermobarometer tube and attach rubber tube full of mercury and clamps for leveling. This can be done by attaching mercury leveling bulb to thermobarometer, running mercury up the tube and drawing water required through the thermobarometer outlet to the KOH reservoir by lowering the mercury level. Then put clamps on the rubber tubing leading to the leveling bulb and cut tubing.

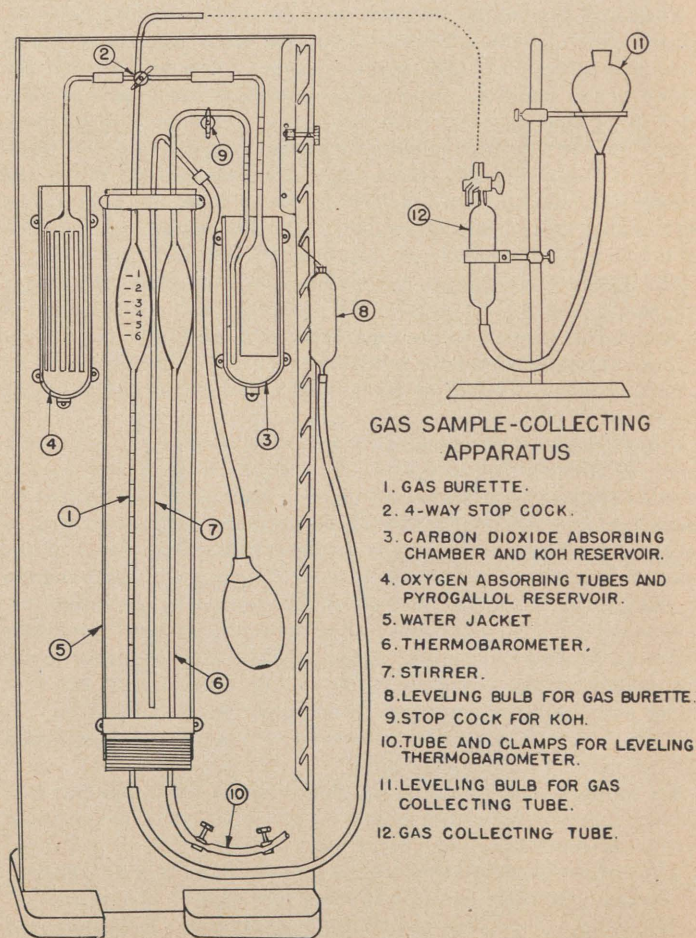

PLATE 91.—Haldane-Henderson gas analysis apparatus.

Set four-way cock to connect burette to carbon dioxide absorption chamber. Run mercury to near top of burette by elevating leveling bulb. Pour KOH solution into its reservoir. Draw solution up into the carbon dioxide absorbing chamber by lowering mercury level in burette.

Shift four-way cock to connect burette to oxygen absorbing chamber. Again run mercury to near top of burette. Pour potassium pyrogallol solution into its reservoir and draw it up into the oxygen absorbing chamber by lowering mercury in burette. Pour some liquid petrolatum into pyrogallol reservoir to protect the solution from the air.

Adjust level of KOH in the thermobarometer connection to the KOH reservoir to one of the marks on this glass tube by means of the leveling tube and clamp on the bottom of the thermobarometer. Next, adjust the level of the liquid in the glass tube to the carbon dioxide absorbing chamber by the burette. It may be necessary to repeat these operations if the liquid in the thermobarometer connection moves appreciably off its mark.

All carbon dioxide and oxygen must be removed from the apparatus, leaving only inert gas in it. This is done by analyzing at least two samples of atmospheric air, which also checks the accuracy of the set-up. The clearing process and the check analysis must be repeated whenever the apparatus stands unused for any length of time.

Gas samples must be sealed with mercury. They are taken with the gas sampling tubes shown on plate 91.

Sealing of  
gas samples.

Open sample tube stopcock and fill tube and cock with mercury from the leveling bulb, then close cock. Gas must be allowed to escape from a high-pressure container through a regulator, or a needle valve, to reduce the pressure. Permit gas to flow through regulator and connecting tube to gas sample tube for a minute to expel air. Open the stopcock, rinsing the sample tube by running mercury up and down, then trap a sample by closing stopcock.

At least two complete analyses should be run on each sample to insure that results are correct.

Connect gas sample bottle to apparatus. Open four-way cock to sample connection. Elevate burette leveling bulb to run mercury to sample bottle stopcock, expelling previous sample, then open sample bottle stopcock. Run mercury up and down in burette two or three times to rinse, then draw in sample by running it down to just above the 10 cc. mark, allowing for pressure of sample. Shift cock clockwise to connect burette to carbon dioxide absorbing chamber and make first reading of burette *quickly*. Run mercury in burette up and down with leveling bulb a few times to absorb the carbon dioxide. Return level of KOH in absorbing chamber tube to its previous mark by adjusting height of mercury in burette. Read burette again. The carbon dioxide content in percent of volume is:

Analysis of  
sample.

$$\frac{\text{Difference between burette reading}}{\text{First burette reading}} \times 100$$

Turn four-way cock clockwise to connect burette to oxygen absorption chamber. Run level of pyrogallol up and down in chamber a few times to absorb oxygen. Return pyrogallol level to original mark on absorption chamber tube, then shift four-way cock counterclockwise to connect burette to carbon dioxide absorption chamber again.

The gas sample is washed in the KOH solution again, then in the pyrogallol. Adjust the level of the liquid each time in the absorbing chamber used before shifting the stopcock.

At the conclusion of the second washing with pyrogallol, shift back to the carbon dioxide absorbing chamber, adjust level of KOH solution, and read burette. Repeat washings until burette scale reading remains constant within 0.04. This is the third burette reading.

The oxygen content of the sample in percent of volume is:

$$\frac{\text{Difference between second and third readings}}{\text{First reading}} \times 100.$$

Precautions during and after operation.

Keep the fluorescent lamp turned off except while actually taking reading. The heat from the lamp will cause temperature changes and errors.

By careful manipulation and practice, bubbles of gas and drops of liquid can be kept out of the apparatus.

If either of the solutions are run over into the burette, they must be drained out and the burette washed out with a 1 percent solution of sulphuric acid.

The length of time required to complete the absorption processes is a measure of the strength of the reagents.

When potassium pyrogallol becomes old and thick, it may clog the small tubes in the oxygen absorption chamber, causing errors due to bubbles and slowing the reaction.

When a test on a sample is finished, leave the levels of the liquids in the connecting tubes at their reference marks to save time. The level of KOH in the thermobarometer connection to the KOH reservoir should not vary more than a perceptible extent during a test.

Once a sample has been taken into the apparatus the blue end of the four-way stopcock handle must not be moved through the upper half of its arc until the analysis is finished.

Bubble air through water jacket with stirrer every 3 to 5 minutes to keep it at same temperature throughout. Do not agitate water enough to make it splash on burette and thermobarometer tubes.

Keep the apparatus and the mercury clean to prevent introduction of errors.

When apparatus is to be left unattended for a time, open stopcock on thermobarometer connection to KOH reservoir to avoid having liquids run over.

Consult standard reference works and text books on analytical chemistry for details of technique.

**SECTION IV. DIVING OUTFIT FOR USING OXYGEN-HELIUM AS DIVING AIR**

LIST AND DESCRIPTION

The use of oxygen-helium mixtures as an air supply for divers requires special equipment. The following special equipment is

issued to submarine rescue vessels in addition to their regular diving outfits.

Item	Number	Unit
Helmet: Complete with breastplate, canister, aspirator, 3-foot length of standard diver's air hose, control valve with adapter and Hoke valve, and recirculator supply hose.	3	No.
Manifold: Complete	1	No.
Gas-mixing outfit:		
Tee for splitting gas flasks, 1/4-inch high-pressure, equipped with 0-3,000-pound gage and 2 left-hand nuts to fit helium flasks.	1	No.
Tee for mixing gas, 1/4-inch high-pressure, equipped with 0-3,000-pound gage, left-hand nut to fit helium flask, and right-hand nut to fit oxygen flask.	1	No.
Electrically heated underwear:		
Large size	2	No.
Small size	2	No.
Panel, complete with switches, ammeter, ammeter shunt, and voltmeter.	2	No.
Storage batteries, 6 volt, 200 A. H.	6	No.
Helium, 200-cubic-foot flasks	100	No.
Oxygen, 200-cubic-foot flasks	20	No.
Spare parts for helmet:		
Injector	3	No.
Hoke valves	5	No.
Discharge nozzle (Venturi)	3	No.
Spare parts for manifold: Pet cocks	5	No.
Globe valve, 1/2-inch, high-pressure, 5,000 pounds	4	No.
Globe valve, 3/4-inch, high-pressure, 300 pounds	2	No.
Valve, relief, 1-inch	1	No.
Gas analysis outfit:		
Haldane-Hendersons	2	No.
Potassium hydroxide, 1-pound bottles	6	No.
Pyrogallol acid, purified, 1-pound bottle	1	No.
Mercury, in 10-pound bottles	5	No.
Leveling bulbs, 2 1/2-inch	6	No.
Rubber tubing, 3/16 x 3/16-inch	50	Feet.
Rubber tubing, 3/8 x 3/8-inch	10	Feet.
Lubriscal (stopcock grease)	10	Tube.
Mineral oil, 1-pint bottles	1	Pt.
Support lift ring, medium	4	No.
Support lift ring, large	2	No.
Ring supports	6	No.
Gas collecting tubes	6	No.
Clamp holders, 3/4-inch	6	No.
Clamps, Bunsen	6	No.
Micrometric control valves, for bleeding sample from helium flask.	2	No.
Shell-Natron, in approximately 234-pound containers, 12 containers to box.	450	Pounds.
Cable for heating electric underwear in 600-foot lengths, with male fittings.	3	Length.
Report on the use of helium-oxygen mixtures for diving	6	No.
Plans showing arrangement and hook-up of helium oxygen gear as used in diving.	25	No.

The ship's recompression chamber should be equipped to supply oxy-helium mixtures to divers undergoing surface decompression. Ten face masks are supplied each vessel for this purpose.

In addition to the above, submarine rescue vessels should provide and maintain satisfactory forms for recording oxygen-helium mixtures and results of dives made with same. The following are samples:

*Oxy-helium mixtures*

Bank No. 1		Bank No. 2		Bank No. 3		Bank No. 4	
Flask No.	Percent O <sub>2</sub>	Flask No.	Percent O <sub>2</sub>	Flask No.	Percent O <sub>2</sub>	Flask No.	Percent O <sub>2</sub>

See record of dive, p. 225.

Diver's helmet  
for oxygen-  
helium  
mixtures.

Standard Navy diving helmets have been converted for diving with oxy-helium mixtures. The principal changes involved the installation of a means of conserving the oxy-helium mixture by absorbing the carbon dioxide in the helmet and so reducing the amount of ventilation required. The oxy-helium helmet weighs about 75 pounds as against 55 pounds for a standard helmet. While a minimum air supply of 1.5 cubic feet per minute at the pressure of the dive is necessary for helmet ventilation in moderate depths of water, divers generally find it more comfortable to use two or three times this amount of air while working in order to reduce fatigue from carbon dioxide. At deep depths, the effect of carbon dioxide is so marked that it becomes important to have a minimum amount of this gas present in the helmet. The oxy-helium mixture enters the helmet through an aspirator nozzle. The action of the aspirator jet draws the carbon dioxide laden atmosphere from the helmet, forces it through a chemical absorbent, and returns it to the helmet with the carbon-dioxide removed. In this way, normal expenditure of the oxy-helium mixture is reduced to about 1 cubic foot per minute at the pressure of the dive.

The interior of the helmet is not changed except to provide openings for the added external fittings. The exterior of the helmet is shown on plates 92, 93, 94, and 95, with the various fittings identified by letters. A description of the fittings follows:

This cable, part (A) plate 92, carries the current supply for the electrically heated underwear. It is standard twin conductor rubber-covered No. 12 portable wire, supplied in 500-foot lengths. It is provided with the old Navy standard battery type telephone cable fittings and is attached to the middle gooseneck. This cable is stopped to the combination lifeline and telephone cable.

The combination lifeline and telephone cable, part (B) plate 95, is a regular 4-conductor cable such as is used with batteryless telephones. It is provided with the usual batteryless diving telephone fittings and is attached to the gooseneck on the left side of the helmet. The cable is crossed over the air hose, led under the diver's right arm, and stopped to the right side of the breast-plate.

The exhaust valve, part (C) plate 92 is the standard air-regulating escape valve of the "non-blow-up" type. The exhaust pipe or channel part (D) is led over the top of the helmet to the rear to clear the canister. During the dive it is normally kept closed, the diver using the chin valve as necessary to regulate his buoyancy. When ordered to "ventilate," the diver holds the chin valve open. If it is necessary to "go on open circuit", the exhaust valve is used in the ordinary way and is opened as necessary to regulate ventilation.

The helmet safety lock, part (E) plate 92 has been shifted to the left front of the helmet to clear the carbon dioxide absorbent canister.

The spit cock, common to the standard helmet, has been removed to provide space for helmet locking device and to prevent possible loss of gas from leakage.

Electric cable  
for heated  
underwear.

Lifeline and  
telephone cable.

Exhaust valve.

Safety lock.

Spit cock.

FRONT VIEW

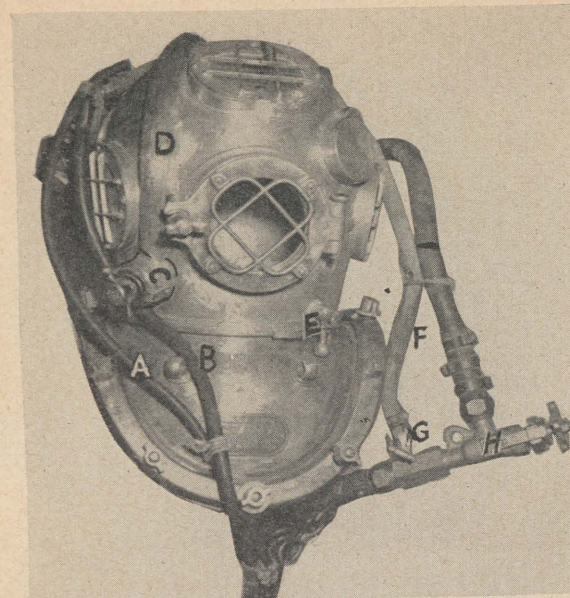

- A—Electric cable for electric heated underwear.
- B—Life line and telephone cable.
- C—Exhaust valve.
- D—Exhaust channel.
- E—Safety lock.
- F—Helium-oxygen supply line.
- G—Hoke valve.
- H—New type control valve.
- I—Air hose.

PLATE 92.—Helmet oxygen-helium (front view).

The oxygen-helium supply line (aspirator supply hose), part (F) plate 92, is a 3½-foot section of standard oxygen hose led from the Hoke valve, part (G), ahead of the control valve to the aspirator, part (C), mounted in the right-hand side of the canister. With this arrangement the diving gas is led to the aspirator jet described below, with the control closed, yet should the diver require a sudden additional air supply of gas, as for instance when descending, he has merely to open his control valve. The working pressure in the aspirator supply hose is maintained at 50 pounds per square inch over bottom pressure. The pressure of the diver's gas supply must be regulated carefully to correspond to the diver's actual depth to avoid rupturing it. It is stopped to the 3-foot length of regular diving hose, part (I). During the dive, the Hoke valve is kept fully open at all times to supply the oxygen-helium mixture to the recirculator nozzle. It should never be closed unless the aspirator supply hose breaks or becomes disconnected.

The control valve, part (H) plate 92, is of the new type of standard control valve with a hexagonal fitting carrying the Hoke valve, part (G), attached to the supply side. During the dive the control valve is kept closed except under the following conditions:

Oxygen-helium  
aspirator  
supply hose.

SIDE VIEW (LEFT)

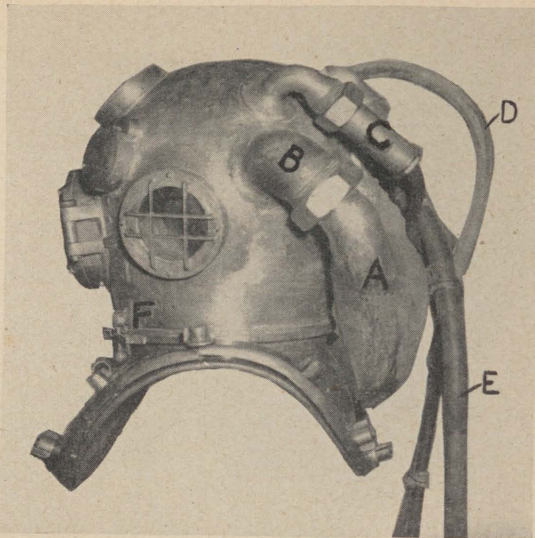

- A—Canister for Shell-Natron (CO<sub>2</sub> absorbent).  
 B—Outlet end of canister.  
 C—Coupling for life line and telephone cable.  
 D—Helium-oxygen supply hose to venturi.  
 E—Air hose.  
 F—Safety lock.

PLATE 93.—Helmet oxygen-helium (side view) left.

SIDE VIEW (RIGHT)

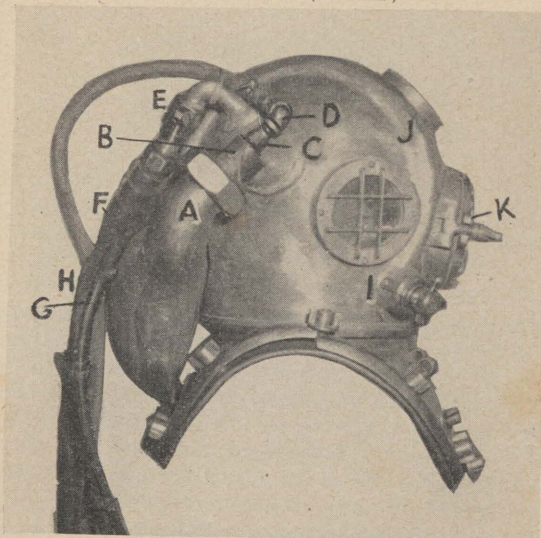

- A—Canister containing Shell-Natron (CO<sub>2</sub> absorbent).  
 B—Inlet end of canister.  
 C—Venturi.  
 D—Helium-oxygen supply to helmet.  
 E—Air inlet and nonreturn safety valve.  
 F—Air hose.  
 G—Electric cable for electric heated underwear.  
 H—Life line and telephone cable.  
 I—Exhaust valve.  
 J—Exhaust channel.  
 K—Face plate.

PLATE 94.—Helmet oxygen-helium (side view) right.

REAR VIEW

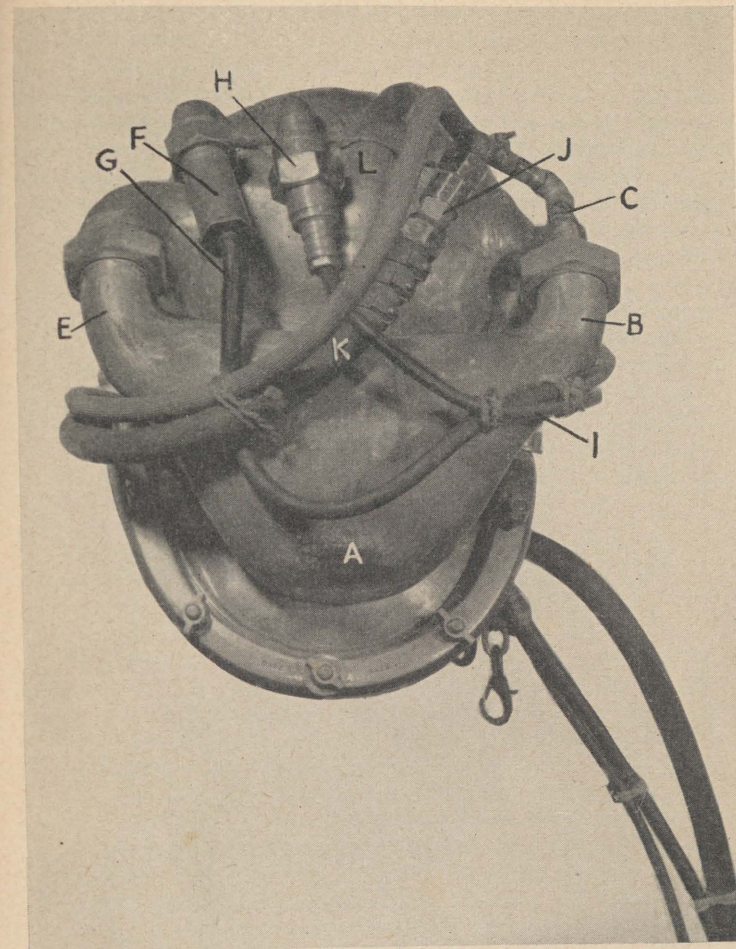

- A—Canister containing Shell-Natron (CO<sub>2</sub> absorbent).  
 B—Inlet end of canister.  
 C—Venturi.  
 D—Helium-oxygen supply to helmet.  
 E—Outlet end of canister.  
 F—Life line and telephone cable coupling.  
 G—Life line and telephone cable.  
 H—Coupling for electric heated underwear cable.  
 I—Electric cable to electric heated underwear.  
 J—Safety non-return valve and air hose connection.  
 K—Air hose.  
 L—Exhaust channel and outlet.

PLATE 95.—Helmet oxygen-helium (rear view).

(a) To build up the pressure and volume of gas in the suit during the diver's descent.

(b) Whenever the diver suddenly requires more gas in his suit to regulate his buoyancy.

(c) To supply gas or air to the helmet in the conventional way in case the recirculating apparatus fails. Use of the control valve in this manner is called "Going on open circuit."

(d) To ventilate the helmet by replacing the gas in the dress with a fresh quantity of gas. The control valve and the exhaust valve are opened on the order, "Ventilate" and closed on the order, "Circulate."

Air hose.

The air hose, part (I), plate 92, is regular diver's air hose. It is attached to the control valve through a hexagonal brass fitting carrying the Hoke gas needle valve. The control valve and hose are attached to the breastplate in the usual way. The 3-foot, 9-inch length of hose is led under the diver's left arm and to the right gooseneck through an ordinary safety nonreturn valve.

RECORD OF DIVE

Diver ..... Rate ..... Depth ..... Date .....  
 Location ..... Purpose .....  
 Oxy-helium bank used ..... percent. Oxygen .....

	Bank pressure	Difference in pressure	Cubic feet used
Started down.....			
On bottom.....			
Off oxy-helium.....			
Total.....			

10 pounds change in bank pressure is 5 cubic feet.

Oxygen: Flask used .....

	Flask pressure	Difference in pressure	Cubic feet used
Started ventilating.....			
After ventilating.....			
Decompression ended.....			
Total.....			

10 pounds change in flask pressure is 1 cubic foot.

Underwear: Volts ..... Amps. .... Temperature of water .....

LOG

Started down.....	Speed of ascent (table I)..... feet per minute
On bottom.....	Time of dive..... minutes
Started up.....	Partial pressure (table III)..... minutes
	Time to first stop..... minutes
	Started ventilating.....
	Finished ventilating.....

Stop	Depth (feet)	Reached	Left	Remarks
First.....				
Second.....				
Third.....				
Fourth.....				
Fifth.....				
Sixth.....				
Seventh.....				
Eighth.....				
Ninth.....				
Tenth.....				
Eleventh.....				
Twelfth.....				

Total time for decompression .....  
 Total time in water .....  
 Remarks .....  
 Recorder ..... Supervisor .....

The aspirator or circulator, as it is called, is a Venturi tube, into the throat of which a jet or nozzle is fitted, having an orifice so proportioned that with 50 pounds per square inch differential pressure, a volume of gas, which contains sufficient oxygen to replace that consumed by the diver, is introduced in the helmet in any given time. Simultaneously the movement of the gas mixture through the nozzle draws the atmosphere from the helmet and forces it through the carbon dioxide absorbent in the canister and then back to the helmet after purification. Any excess gas that tends to accumulate escapes through the exhaust valve. By this means, the helmet is given sufficient ventilation and the amount of gas which is required is only about one-fifth of that used in the old method of ventilation. The aspirator is shown in its assembled form, as part (C), plate 95, and in cross section on plate 97.

Venturi or recirculating aspirator.

The connection to the aspirator, as shown on plate 97, consists of a 1/4-inch pipe elbow to which the aspirator supply hose connects. This elbow is screwed to an oxygen hose adapter containing a fine wire gage screen. It is important that this strainer be kept in good condition to prevent solid matter blown along the hose from plugging the nozzle. The strainer screws into the high pressure nozzle fitting with a 1/4-inch pipe thread.

Connection to aspirator.

The high-pressure nozzle fitting as shown on plate 97 is threaded into the aspirator body with a metal to metal joint, no packing being used. It can be removed for cleaning with a 3/4-inch wrench.

High-pressure nozzle fitting.

The nozzles are machined to extremely accurate dimensions and finishes. The relative position of the nozzles must also be exactly as designed. They must be handled very carefully. A nearly invisible scratch or a tiny bit of foreign matter around the nozzles will alter the flow of the gas and will result in inadequate ventilation of the helmet. The dimension of the jet orifice is 0.0225 inch, or No. 74 drill size.

Nozzles.

Each time a helmet is used, inspect the strainer and nozzles. Make sure the high pressure nozzle is clean by running a No. 74 drill through it from the high-pressure side. If the drill is soldered to the end of a small brass rod about 4 inches long, it can be inserted into the nozzle easily.

After the helmet is used, the nozzles should be removed and blown clean and dry before being put away.

The jet produces a low rumbling noise. Any change in this sound may indicate that the recirculating system has failed.

The discharge nozzle, plate 97, is a Venturi tube. The jet of gas from the high pressure nozzle rushing through the throat of the venturi sucks the atmosphere from the helmet and forces it through the canister. The discharge nozzle is screwed into the lower side of the aspirator body and projects down into the canister. It can be removed with a 3/4-inch wrench.

Discharge nozzle.

Carbon-dioxide absorbent is a compound known commercially as Shell-Natron. The particles are moulded to permit easy flow of gas through the material. Shell-Natron has a very high affinity for carbon dioxide. It is extremely caustic and will produce active burns if it comes in contact with the skin. It is packed in 2 3/4-pound containers, 12 containers to a box. Shell-

Carbon dioxide absorbent.

Natron must be kept completely dry and air-tight to prevent absorption of moisture and carbon dioxide from the air.

#### Canister.

The canister, part (A), plates 94 and 95, holds a little over a carton of Shell-Natron when the baffle is installed, or about 3 pounds of absorbent. This quantity probably will continue to absorb carbon dioxide effectively for about 7 hours. It should be changed after 3 hours of use.

The discharge (left) end of the canister is fitted with a removable screen to prevent the absorbent from entering the helmet. Shell-Natron which has powdered should not be used because the caustic dust will be blown into the helmet.

The canister is attached to the helmet with two large nuts which can be turned with a 3-inch wrench. Leather washers inside the nuts make the connection watertight. In assembling the recirculating system it is essential that all connections be completely tight to avoid loss of gas and to prevent water from reaching the Shell-Natron.

With the canister removed from the helmet, fill it carefully with Shell-Natron from both ends. Leave an empty space in the aspirator end of the canister to accommodate the discharge nozzle. Shake the absorbent down enough to insure that the canister is otherwise filled completely. As originally issued, there were no baffles in the canister so any unfilled pockets would pass the gas over the absorbent instead of through it and the carbon-dioxide would not be removed. A baffle, plate 96, was subsequently installed in accordance with Bureau of Ships letter August 14, 1941, No. ASR/S94 EN28/A2-11. After use, remove the Shell-Natron from the canister and wash out thoroughly with fresh water. Any absorbent left in the canister will produce heavy corrosion.

#### Oxygen-helium diving manifold.

The manifold shown on plates 98 and 99 is used to control the supply of gas to the diver and as a storage rack for the gas flasks. Oxy-helium mixture is supplied at 50 pounds per square inch over water pressure during the dive. This is changed to pure oxygen during the decompression at the 60-foot stop. In an emergency, compressed air can be supplied to the diver. These three systems will be explained in detail.

#### Oxygen-helium system—Assembly of.

The helium flasks containing the oxy-helium mixture are arranged in a steel rack in four banks, a, b, c, and d, plate 99, with five flasks to the bank. Only helium flasks, which have a left-hand thread, will fit the flask connections on the manifold. All flask stop valves are opened and one bank at a time is used by opening the stop valve to that bank. Flasks in an exhausted bank can be replaced with full flasks without interrupting the supply to the diver.

#### Flow of mixture.

The mixture flows from the bank in use through a strainer to the Grove pressure regulator. The flask pressure is reduced by the regulator to the pressure required by the diver, 50 pounds per square inch over water pressure. The oxy-helium is supplied from the Grove regulator, part (P) plate 98, to the diver via a volume tank, part (T), plate 98.

#### Test pressures.

The test pressure for the high-pressure portion of the system is 3,000 pounds per square inch and for the low-pressure portion,

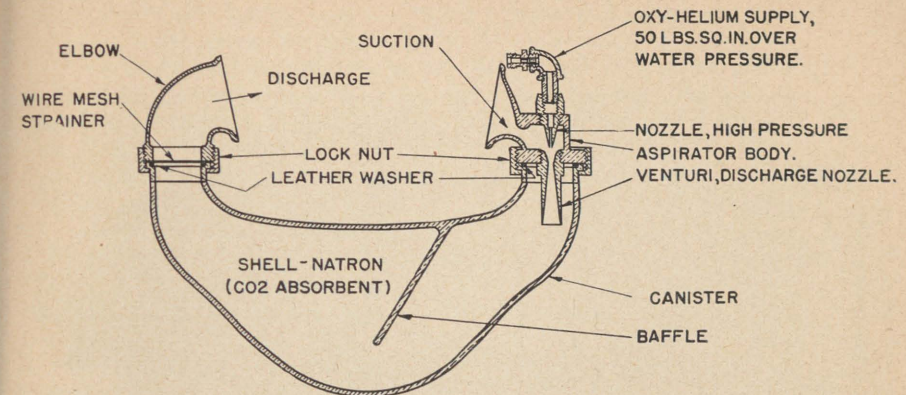

#### SECTION OF RECIRCULATING SYSTEM

PLATE 96.—Helmet oxygen-helium, section of recirculating system.

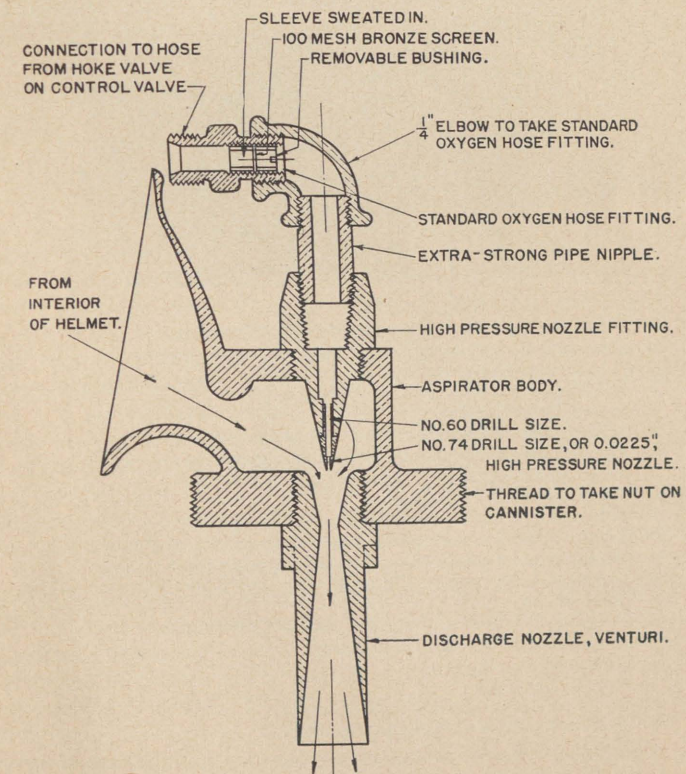

#### SECTION OF RECIRCULATING DEVICE

PLATE 97.—Helmet oxygen-helium, cross section of aspirator and discharge nozzle venturi.

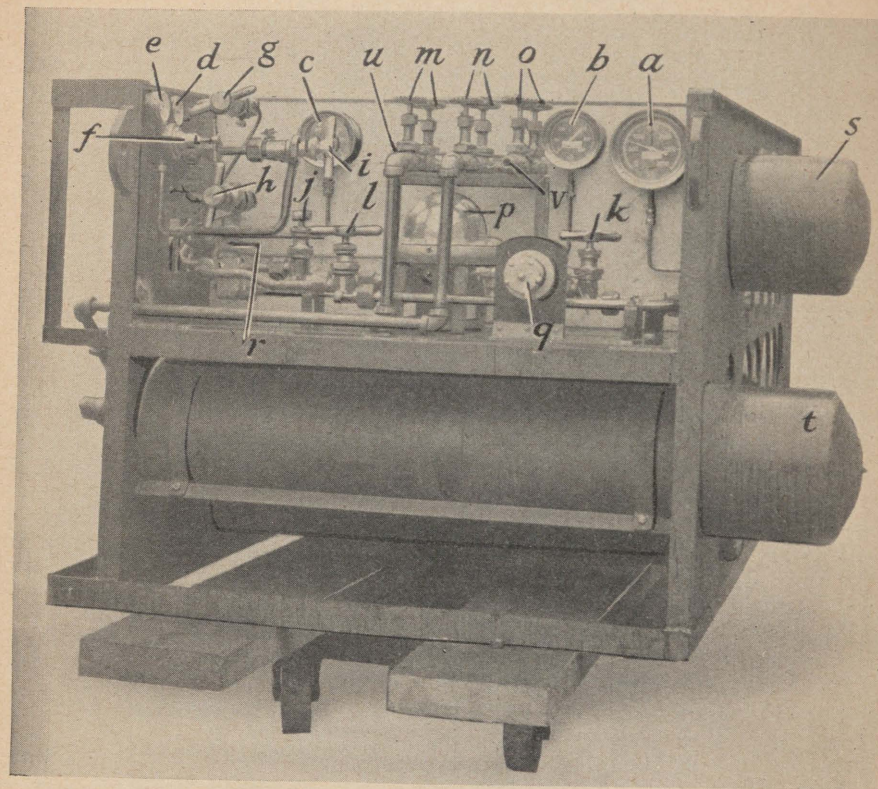

- a—3000-pound gage, helium-oxygen bank pressure.
- b—600-pound gage, helium-oxygen divers' supply pressure.
- c—600-pound gage, oxygen (pure). Oxygen volume tank pressure.
- d—H. P. gage—oxygen (pure) flask pressure gage.
- e—Oxygen gage—oxygen volume tank pressure.
- f—Oxygen (pure)—regulator.
- g—Oxygen (pure)—upper oxygen flask supply or cut-out valve.
- h—Oxygen (pure)—lower oxygen flask supply or cut-out valve.
- i—Oxygen (pure)—bypass valve (from flask to volume tank).
- and k—Cut-out valves, Grove reducer.
- l—Helium-oxygen bypass valve (to bypass Grove reducer).
- m—Helium-oxygen manifold valves (from helium-oxygen volume tank to diver).
- n—Oxygen (pure) manifold valves (from oxygen volume tank to diver).
- o—Air manifold valves—divers' emergency air supply from ship's air manifold.
- p—Grove reducer.
- q—Dome loader—regulates pressure in dome of Grove reducer.
- r—H. P. strainer for helium-oxygen banks.
- s—Helium-oxygen volume tank.
- t—Oxygen volume tank.
- u—Divers' air (helium-oxygen) hose connection.
- v—Air hose connection from ship's air manifold.

PLATE 98.—Oxygen-helium diving manifold front (end) view.

500 pounds per square inch. Working pressure of low pressure portion is 300 pounds per square inch.

Two flasks of pure oxygen, parts (I) and (J), plate 99, are placed in the rack below the oxy-helium volume tank. The stop valve on each flask is opened wide. The piping from each flask is equipped with a stop valve, parts (G) and (H), plate 99, on the control panel which cuts in the flask to an ordinary oxygen pressure regulator having high and low pressure gages. The regulator reduces the oxygen flask pressure to the pressure required by the diver, 50 pounds per square inch over water pressure, and discharges it to the diver's hose via the oxygen volume tank. A valve part (I), plate 98, is provided for bypassing the oxygen regulator in case it fails.

If the oxy-helium or oxygen system fail, the diver can be shifted to compressed air. A length of standard diver's air hose from a regular diver's air supply is attached to the air hose connection, part (V), plate 98, at the control panel. When the diver is shifted to compressed air, he should continue to "Circulate" for 20 minutes without "Ventilating" before he goes on "open circuit." This will prevent his suddenly becoming dizzy from the anaesthetic effect of the nitrogen.

The oxygen-helium volume tank, part (K), plate 99, has a capacity of about 3.75 cubic feet. It is equipped with a relief valve having a 300-pound spring installed and set to lift at 275 pounds per square inch. Spare springs of 400 and 500 pounds are supplied. The test pressure of the tank is 1,000 pounds per square inch.

The oxygen volume tank, part (N), plate 99, is of the same size as the oxy-helium volume tank and has an identical relief valve with spare springs.

The connection to diver's air hose is with a standard S fitting attached to a manifold at the top center of the control panel, as shown by part (U), plate 98. This manifold has six valves, parts (M), (N), and (O), plate 98. Two are stops for the oxy-helium system, two for the oxygen system, and the other two control the compressed air supply. Between the two stop valves in each system is a pet cock accidental leakage between systems.

The Grove pressure regulator, part (P), plate 98, automatically reduces the flask pressure of the oxy-helium mixture to that required by the diver. It is similar in construction to other diaphragm-operated regulators except that instead of a spring against the diaphragm being used to control the discharge pressure a dome over the diaphragm is charged to a suitable pressure. As installed, the dome pressure is adjusted from the high pressure side of the line to give the desired discharge pressure by turning the handle on the dome loader. In case the dome loader does not operate, the discharge pressure can be regulated by inserting the proper wrench in a small fitting on the flange of the dome.

The pressure delivered by the regulator must be carefully adjusted to 50 pounds per square inch over the water pressure corresponding to the actual depth of the diver. A pressure lower than this amount will prevent proper functioning of the diver's recirculating system. This requires continuous changing of the

Oxygen system.

Compressed air system.

Oxygen-helium volume tank.

Oxygen volume tank.

Connection to diver's air hose.

Grove pressure regulator.

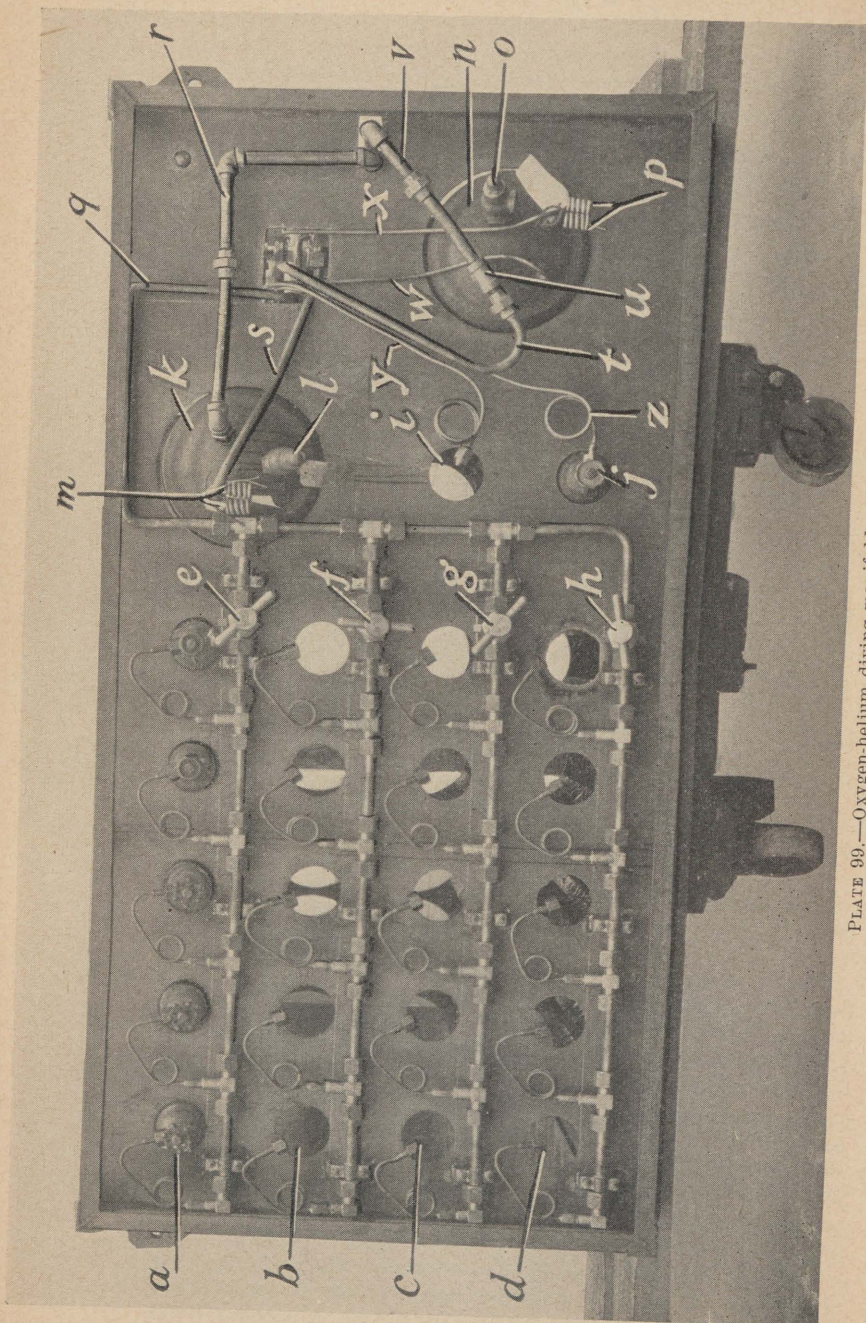

PLATE 99.—Oxygen-helium diving manifold, side view.

dome loader setting while the diver is going down and coming up.

The most likely causes of derangement of the regulator are failure of diaphragm and worn or damaged valve parts. New parts may be obtained upon requisition to the Bureau of Ships.

1. Helium conducts heat much more than does air. When diving with oxy-helium mixtures, the heat is carried from the diver's body so rapidly that special provision must be made to keep him from becoming cold. Helium penetrates fabrics and other materials so actively that electrically heated diver's underwear had to be developed for diving with oxy-helium mixtures.

2. The heating elements consist of fine interwoven wires arranged in multiple series-parallel circuits. Each wire is insulated with spun glass thread wound around it. The wires are placed between two layers of spun glass cloth and are sewn to one layer with glass thread. The inside and outside of the garment is knitted wool, dyed blue and impregnated to make it fire resistant. The high concentrations of oxygen in the dress increases the possibility of igniting materials which ordinarily will not burn readily, hence the glass insulation and fire-resistant impregnation. The underwear and the means for operating it are shown on plate 90.

3. Six 6-volt, 200 ampere-hour storage batteries are supplied to furnish the current for the underwear. The leads from the batteries are lead to switches on the panel so that any number of batteries can be used at one time in series, giving 6 to 36 volts on the leads to the underwear in 6-volt steps. Only one switch at a time should be in the "On" position, otherwise one or more of the batteries will be short circuited. It is necessary to have the batteries and all parts of the circuit well insulated from grounds to avoid giving the diver a possible shock that will be uncomfortable, but not dangerous.

4. 500 feet of No. 12 twin-conductor portable wire is supplied for the underwear conductor. It is led into the helmet through a gooseneck using the old style battery type telephone connections.

Electrically heated underwear.

Heating elements.

Electric current.

Conductor.

#### Description of Plate 99.

- a, b, c, d—Helium-oxygen banks (5 flasks per bank).
- e, f, g, h—Helium-oxygen bank manifold cut-out valves.
- i—Upper oxygen (pure) flask.
- j—Lower oxygen (pure) flask.
- k—Helium-oxygen (mixture) volume tank.
- l—Relief valve.
- m—400- and 500-pound springs for relief valve (300-pound spring installed).
- n—Oxygen (pure) volume tank.
- o—Relief valve.
- p—400- and 500-pound springs for relief valve (300-pound spring installed).
- q—Helium-oxygen (mixture) line from manifold to reducer.
- r—Helium-oxygen (mixture) line from helium-oxygen volume tank to divers' helium-oxygen supply manifold (see "M" on end view).
- s—Helium-oxygen line from Grove reducer to helium-oxygen volume tank.
- t—Oxygen line from oxygen bypass valve (see "i" on end view).
- u—T-fitting—connecting oxygen bypass line and divers' oxygen supply line to oxygen volume tank.
- v—Oxygen line from oxygen volume tank to divers' oxygen manifold.
- w—Oxygen gage line (see "e" on end view).
- x—Oxygen supply line from oxygen regulator to oxygen volume tank.
- y—Oxygen supply line to cut-out valve (see "g" on end view).
- z—Oxygen supply line to cut-out valve (see "h" on end view).

Connection to the underwear is made inside the helmet with a small bakelite plug and jack placed on the left side of the diver's face clear of his telephone.

Electrical  
resistance.

5. The resistance of the dress is about 2 ohms and it is designed to operate on a maximum current of 15 amperes. The resistance of the cable must be considered in calculating the voltage required to obtain the desired current. For example: No. 12 wire has a resistance of 0.00162 ohms per foot. Five hundred feet of twin conductor cable will have 1,000 feet of No. 12 wire with a resistance of 1.62 ohms. The resistance of the circuit through the dress will be 2 plus 1.62, or 3.62 ohms. The maximum current obtainable from the 36-volt supply will then be about 10 amperes. To furnish 15 amperes, it will be necessary to add three more 6-volt batteries to the supply in order to raise the potential to 54 volts. The actual current through the underwear is read directly from the ammeter on the panel. Divers report being comfortable in water of 46° F., using 11.5 amperes.

Care in  
handling  
underwear.

6. The underwear must be handled carefully to avoid breaking the wires in the heating elements. Do not fold or crease it, but stow it on hangers in a clean dry place.

#### SECTION V. DIVING PROCEDURE WHEN USING OXYGEN-HELIUM MIXTURES

Dressing the  
diver.

1. The diver puts on the electrically heated underwear which replaces all of the diver's underwear usually worn. If desired, the diver may protect his head by wearing a leather aviator's helmet buckled securely under his chin with holes cut in the ear flaps to permit him to hear.

2. A standard rubber diving dress in good condition and equipped with gloves is worn. Place electric plug on the left side of diver's neck. The breastplate nuts must be well set up to avoid any leaks. Use a full belt.

3. Inspect the connections to the helmet to see that they are tight and properly made up. A safety nonreturn valve must be used. See that the aspirator high-pressure nozzle is clear and clean.

4. Screw helmet on breastplate, open faceplate, attach control valve to breastplate, then stop lifeline and heating cable to right side of breastplate and hose to left side. Connect underwear heating plug and jack on the left side of the diver's face. Test the underwear by turning on the lowest voltage available and noting the ammeter reading. Test the telephones.

5. Check the filling of the canister. Place screen in left (discharge) connection and leather washer in each connecting nut. Attach canister to helmet, setting up on nuts with wrench. Turn on oxy-helium supply with a pressure of 75 pounds square inch and listen to sound of aspirator. Diver opens and closes control valve to test it and the safety nonreturn valve. Close exhaust valve. Close face plate. Diver is ready to enter the water.

6. There should be no leaks anywhere in the dress and there must be none at all in the recirculating system, particularly the canister. The entire operation of dressing is done more con-

veniently with the diver seated on a stool. He should be lowered into the water on a stage because the weight of the dress makes it very difficult for the diver to handle himself out of the water.

7. During the descent, the diver uses his control valve to keep his dress inflated. After he reaches the bottom, the control valve is kept closed. The recirculating system then replenishes the oxygen and provides the necessary ventilation. The exhaust valve is kept closed, the diver using his chin valve occasionally to regulate his buoyance. The control valve may be opened if the diver needs a sudden increase of atmosphere in his dress.

Procedure  
during descent  
and on bottom.

8. When he receives the order "*Ventilate*," the diver opens his control valve about one-quarter turn and holds the chin valve open. This is done either to renew the atmosphere in the dress, or to remove the oxy-helium mixture from the dress when shifting to pure oxygen during the decompression. The diver may ventilate his dress at intervals on the bottom if he is working hard, or is not satisfied with the adequacy of the recirculating system.

9. At the order "*Circulate*," the diver closes his control valve and releases the chin valve, permitting the recirculating system to supply him.

10. The order "*Go on open circuit*" means to open both the control valve and the exhaust valve, operating the dress in the same way that the conventional compressed-air dress is used. This must be done if the recirculating system fails. If the diver notices from the sound of the aspirator jet that the circulating system is not working, he should shift at once to "open circuit," reporting his action via telephone and by signal.

11. The acoustical properties of diver's telephones have generally been poor. When diving with oxy-helium, the density of the mixture being different from air, a peculiar property is imparted to the sound of the voice. It is almost impossible to understand the diver. Experimental types of telephones with tonal control built into the amplifier have given better results. With experience, men learn to adapt their voices somewhat to the helium atmosphere.

Communication.

12. It is an excellent practice for the diver to speak over the telephone about once a minute during the dive. A continuous description of the conditions he encounters and a report of what he is doing will give him something to talk about and may be extremely useful information.

13. The following special hand signals with lifeline and air hose seized together are recommended for use in case the telephone fails:

- 1-2 pulls—Reduce current to underwear.
- 1-3 pulls—Increase current to underwear.
- 3-2 pulls—"Ventilate" or "Go on open circuit."
- 4-3 pulls—"Circulate."

14. When made by the diver, these signals indicate that the diver is carrying out the operation indicated.

Ascent.

15. Speed of ascent is an important factor in the decompression. The diver should keep himself heavy while coming up, permitting

the tenders to haul him up at the proper rate. A stage which can be used to land the diver on deck is the best arrangement for decompression.

16. *Undressing* is done most easily with the diver seated on a stool. Open the faceplate, remove the canister, unfasten lifeline, air hose, and control valve from breastplate. Disconnect underwear from helmet and remove helmet. Proceed with undressing in same manner as with compressed air outfit.

## CHAPTER XIX

### SALVAGE, SALVAGE VESSELS, AND SPECIAL GEAR

Perhaps the foremost duty of Navy Divers is in salvage operations varying from the recovery of small items such as anchors, sunken torpedoes, etc., to the raising of sunken submarines and the salvaging of surface wrecks. The procedure in the recovery of the smaller items varies with the circumstances in each case and usually embodies such a multiplicity of varying conditions that no attempt will be made to describe such operations in this chapter.

General.

Vessel salvage operations are normally of two classes: namely, (a) submarine, (b) beach. In the former instance the wreck is completely submerged and therefore all the work in preparing the wreck for raising must be accomplished by divers. In the latter case the wreck is but partially submerged and divers are usually necessary only for external hull and underwater terrain examinations.

Types of salvage.

In submarine salvage it is necessary to raise the wreck to the surface prior to towing to the drydock for reconditioning. When submarines have suffered considerable damage to their watertight integrity, it is necessary to provide sufficient external buoyancy by pontoons or other means to provide a lifting force of a magnitude capable of breaking the suction of the bottom and to provide positive buoyancy for lifting to the surface. Inasmuch as submarines are designed as underwater craft, it is usually possible to make watertight many of the compartments of the ship and in this manner provide many tons of internal buoyancy.

Many surface craft have sunk to a depth sufficient to submerge the entire ship. The smaller ships can be raised by the aid of lifting cranes or by the use of floating buoyancy members, the lifting force being supplied by powerful winches or by the rise and fall of the tide. The larger vessels may be salvaged by making the hull watertight and by displacing the water within by compressed air. The reclamation of the scuttled German Fleet at Scapa Flow is an impressive example of this method of salvage.

Surface salvage is accomplished by many different means, and the method used is dependent upon the circumstances surrounding each case. Many vessels are refloated by lightening ship and pulling off at high tide. Others are forced to avail themselves of additional means such as the use of beach gear and towing power of other ships, and again it is necessary to dredge the bottom from around the ship to provide the necessary draft to refloat the vessel. Pontoons, barges, or other external buoyancy members are frequently called upon to assist in raising the ship a sufficient degree to clear bottom.

The use of divers in the salvage of surface wrecks is of a minor nature and therefore this chapter will devote itself mainly to submarine salvage in which divers play a major and indispensable part.

Composition  
of salvage  
squadron.

Salvage squadrons consist of the salvage and attendant vessels, pontoons, and other salvage gear, and a complete staff of salvage personnel including experienced divers. The number of the above is dependent upon the size of the vessel to be salvaged, the extent of damage to the wreck, and other miscellaneous factors such as the depth of water for submarine wrecks, navigational hazards, etc. In submarine wrecks, a submarine rescue vessel is usually designated as the salvage and diving vessel and the other vessels stand by as attendant vessels. Each ship has a specific function in the salvage operations. The diving ship is moored directly over the wreck so that the divers can be readily lowered to the desired location. Usually a sister ship of the sunken submarine is ordered to stand by in order that the divers can familiarize themselves with the location and operation of an exact replica of the corresponding part of the sunken craft prior to descending to accomplish a certain task. The United States Coast Guard and the United States Lighthouse Service have cooperated wholeheartedly with the Navy in previous salvage operations, and the salvage forces would have been seriously handicapped without their aid.

The Navy has converted minesweepers of the bird class to submarine rescue vessels. The vessels are normally stationed at submarine bases.

Submarine  
rescue  
vessels.

These ships have the following characteristics: standard displacement 1,060 tons; designed speed 14 knots; length 180 feet; beam 36½ feet; draft 10½ feet. They are excellent sea vessels and are especially suitable for submarine rescue purposes. The installation of additional equipment made necessary by advances in the art of diving has crowded the diving vessels to a considerable extent. The attendant vessels can relieve the crowded condition of the diving vessels during salvage operations in many ways such as quartering salvage personnel, manufacture of salvage equipments, etc.

Salvage  
equipment.

Submarine rescue ships are required to be equipped with many items of special salvage gear including the following items of major importance:

- (a) Diving outfits.
- (b) Recompression chamber.
- (c) Compressed-air supply.
- (d) Pontoons and pontoon gear.
- (e) Underwater cutting and welding outfits.
- (f) Washing nozzles and lances.
- (g) Cement guns.

Beach salvage gear is chiefly carried at established salvage stations and depots.

Diving outfits.  
Decompression  
chamber.

Diving outfits are fully described in chapter III.

Recompression chambers are essential to deep diving operations, not only for treatment of caisson disease but also to prevent the contraction of the disease on emergency ascents and under other conditions requiring the diver to be brought rapidly to the surface.

The present standard type recompression chamber is designed for working pressures not exceeding 200 pounds per square inch.

The standard recompression chamber is cylindrical in form and is divided into three separate airtight compartments. The largest lock (medical lock) contains all the equipment used in decompression and is the lock in which the diver is placed during the decompression operation. The man lock is much smaller and is used for equalizing pressures for persons entering or leaving the medical lock while decompression is in progress. The air lock is used for passing supplies or equipment into or out of the medical lock. Duplicate valves permit control of air pressures either from the interior or exterior of the medical and man locks. Suitable connection boxes and deadlights are placed to allow for telephone and vessel communication with persons within the chamber.

The Navy standard recompression chamber is shown on plate 100 in which the compressed air piping, valves, and fittings have been omitted to permit greater clarity.

Compressed air may be obtained from three separate sources on submarine rescue vessels as follows:

Compressed  
air supply.

(1) Diver's air supply consists of two compressors capable of supplying approximately 150 cubic feet per minute at a pressure of 400 pounds per square inch.

(2) Salvage air supply consisting of a dual set of low pressure compressors capable of supplying air at 150 pounds per square inch.

(3) High-pressure air banks containing air at approximately 2,500 pounds per square inch.

The high-pressure air banks are usually carried as an emergency air supply but may be used for deep-sea diving where the conditions are such that the air supplied by the 400-pound capacity compressors is inadequate. In special cases such as the final blowing of pontoons and watertight compartments in the raising of submarines, compressed air is also furnished by the attendant vessels. All submarines possess high-pressure air banks and especially lend themselves as a reserve air supply. A diagrammatic sketch of a typical layout of the diving air and salvage air supply is shown on plate 101.

The air supply to divers must be at the correct pressure and temperature and must be free of carbon dioxide or other undesirable impurities. It must not contain excess moisture, especially when diving in cold water where such moisture may freeze in the air lines and shut off the divers' air supply.

The excess moisture is separated from the divers' air supply by compressing and cooling of the air to a point where the relative humidity exceeds 100 percent, at which point the moisture condenses and is drawn off. The air is then expanded to the desired diving pressure with the relative humidity decreasing accordingly. Further air conditioning is often necessary by air heaters or air coolers as the circumstances warrant. These units are usually permanently installed in the divers' air supply line equipped with bypasses to cut out each unit if that particular phase of air conditioning is not desired.

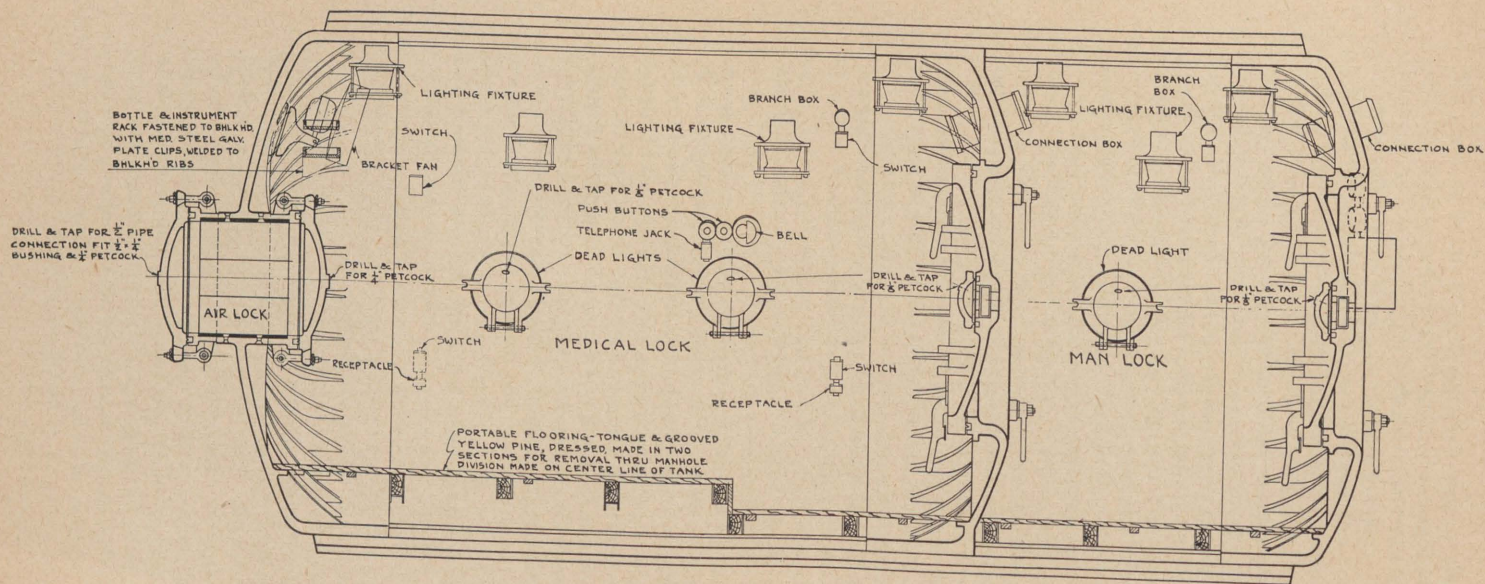

LONGITUDINAL SECTION  
 PLATE 100.—Navy standard recompression chamber.

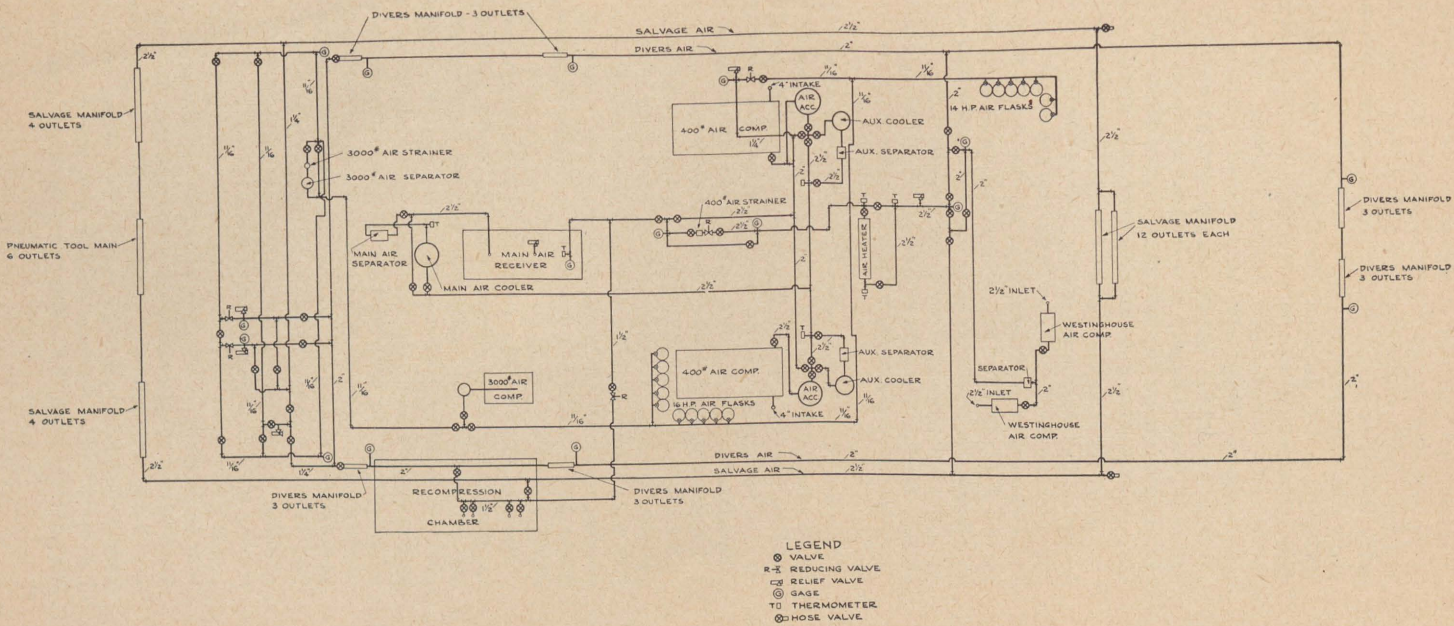

PLATE 101.—Diving and salvage air lines on submarine rescue vessels.

LEGEND  
 ⊕ VALVE  
 R½ REDUCING VALVE  
 ⊕ RELIEF VALVE  
 ⊕ GAGE  
 ⊕ THERMOMETER  
 ⊕ HOSE VALVE

Pontoons and pontoon gear.

The use of pontoons in salvage operations has led to the development of the larger 3 compartment type pontoons. Originally pontoons were constructed to give a maximum lift of 60 tons while the deadweight of the empty pontoon was 35 tons. The later types are approximately 32 feet long by 12½ feet in diameter giving an 80-ton buoyancy lift from an empty deadweight of 35 tons. Pontoons are normally divided into 3 watertight compartments, each compartment having separate vent, flood, and air relief valves. Each end compartment contains a hawse pipe through which the lifting chains are passed and secured by means of chain stoppers or wire rope stoppers. The controls to each compartment are usually painted different colors to permit easy identification and to avoid confusion when submerged.

A wood sheathing is placed around the cylindrical metal tank to protect the tanks from injury. When towing in rough weather, the pontoons are very active in the sea due to their great buoyancy and frequently crash together or against other shapes with great force. It is therefore imperative that great care should be taken to protect the pontoons from excessive sheathing wear or from puncture due to contact with sharp projections. A diagrammatic sketch, showing the piping, flooding, and blowing arrangements of Navy standard pontoons with their lowering lines, etc., is shown on plate 102.

Pontoons may be transported to the scene of salvage operations by stowing on the deck of barges or other vessels or by towing.

Underwater cutting and welding outfits.

There are two kinds of underwater cutting outfits, namely, oxygen-hydrogen torches and electric arc torches. The gas torches have been found to possess the hotter flame but the electric arc torch, while slower, is more adaptable and dependable for underwater use in that it will cut all commercial metals and adjustment is not necessary after descending under the surface. The oxygen-hydrogen torches will not cut nonferrous metals and adjustment must be made to control the length of the cutting flame which in turn is dependent upon the external pressure or depth of water.

Oxygen, supplied to the tip of the electric arc torch, serves to increase the flame temperature and to form a gas bubble in which the arc burns. The apparatus can be adjusted at the surface prior to the descent of the diver. No further adjustment is necessary after submersion regardless of the depth of the water in which the cutting is to be done. Underwater electric arc cutting usually requires up to 300 amps at 50 to 60 volts across the arc. The oxygen is supplied at approximately 60 pounds per square inch in excess of the pressure at the depth at which the diver is working. A sketch of the Navy type oxy-hydrogen underwater cutting torch is shown on plate 103.

For underwater work the Navy uses electric arc welding. Current is supplied preferably by a 200- or 300-ampere commercial welding set at approximately 185 amps and 35 volts across the arc, but the 50-kilowatt generator, such as that used with the underwater cutting torches, may be used, when modified, for welding operations. Surface electric arc sets can be converted to underwater work by using an insulated electrode, electrode

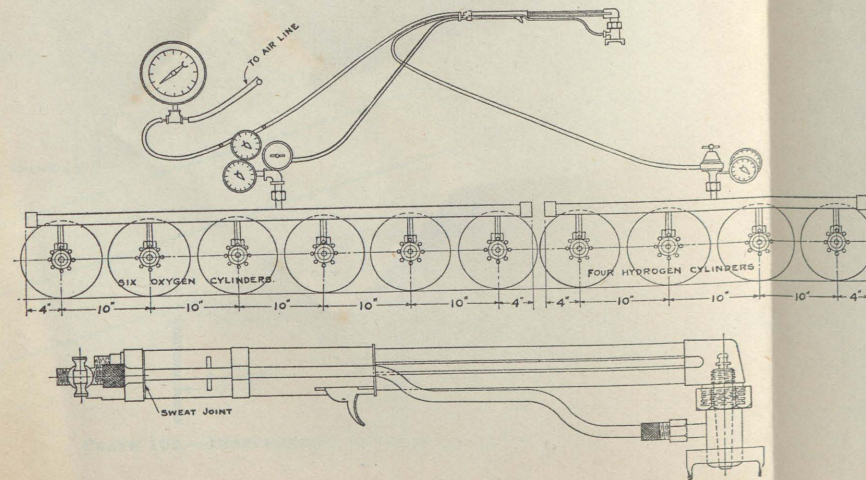
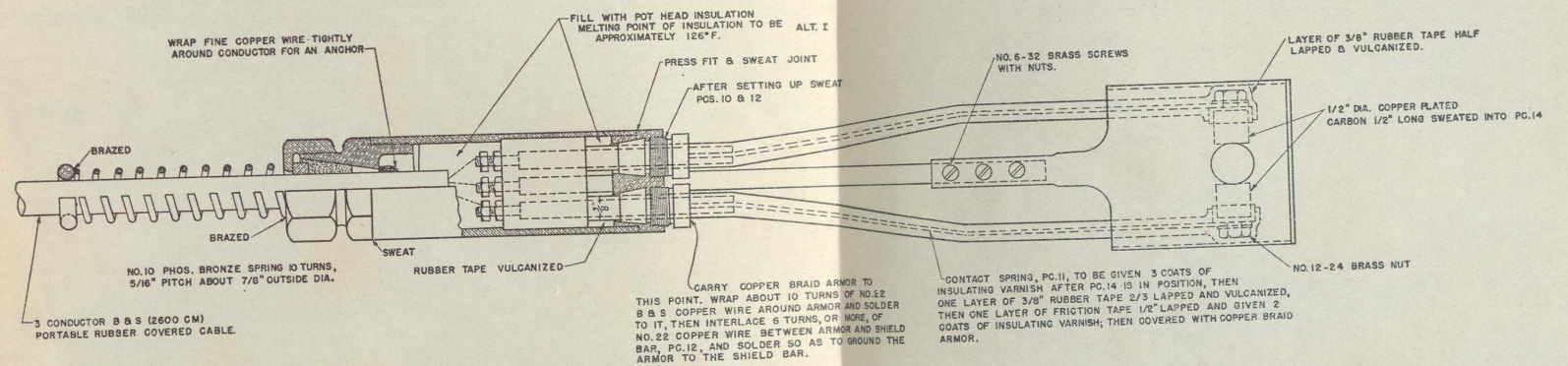
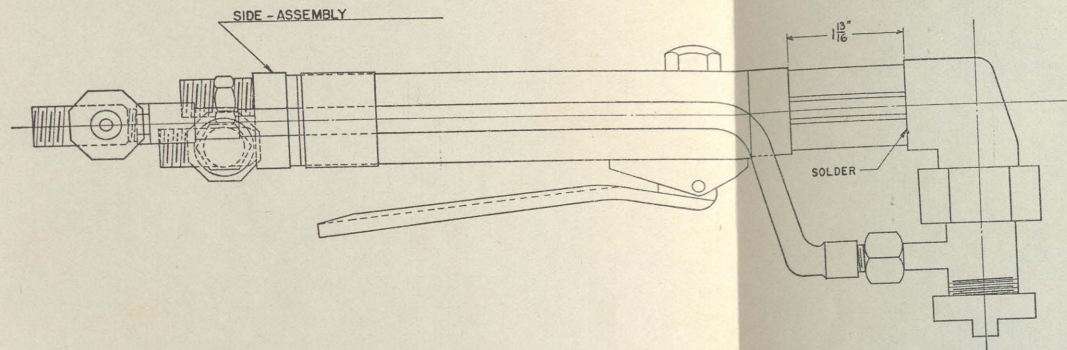
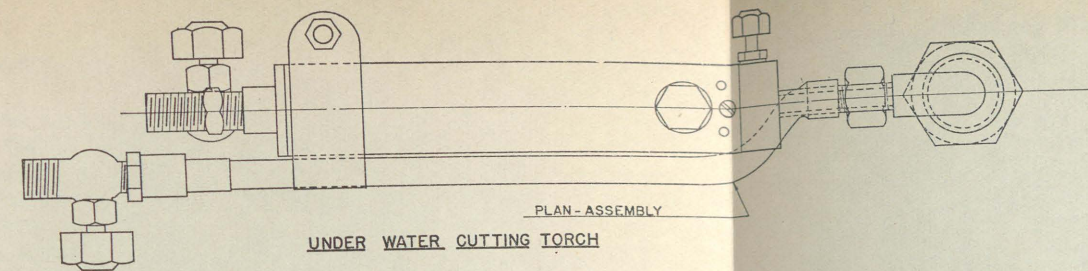

PLATE 103.—Oxy-hydrogen under-water cutting torch.

holders, and the cable designed for use with the electric underwater cutting torch. The electrodes should never be burned to less than  $1\frac{1}{2}$  inches of length as the heat would damage the rubber cover of the holder thereby seriously handicapping replacement of new electrodes.

A new underwater cutting torch is being procured and supplied to the fleet at this time. This torch is of the arc oxygen type having a chuck head permitting ready renewal of electrodes. The electrodes are hollow-coated steel rods. This coating is a lime uclon mixture. The outfit can be operated from the standard 300-ampere welding machine, and is much more efficient than any method previously used. Detailed instructions are supplied with each outfit.

Divers should wear a supplementary face piece or goggles whenever performing cutting or welding. The face-piece guard obstructs the diver's view and therefore must be removed, necessitating the replacement of the ordinary face-piece with a non-shatterable glass facepiece. Care should be taken in checking

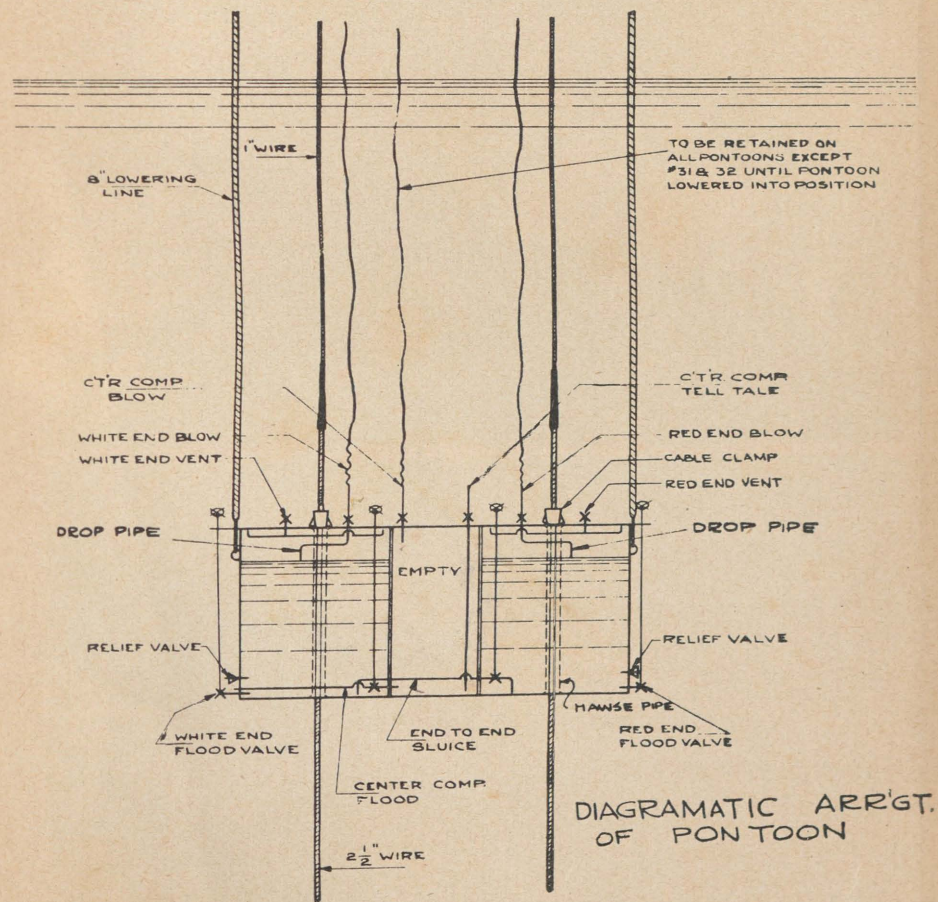

PLATE 102.—Diagrammatic arrangement of pontoon.

the level of the facepiece frame with the curvature of the non-shatterable glass to prevent cracking on installation.

After all cutting or welding operations, the diver's exhaust valve should be overhauled and thoroughly cleaned to remove minute particles which frequently deposit on the exhaust channel or valve seat.

**Underwater  
velocity  
power tools.**

Velocity power tools should be especially adapted to underwater use and to any other type of work where the operator is physically restricted. Of special value in salvage operations is the cable cutter and the power driver. The other velocity power tools are the pipe bonder, rivet expander, rivet remover, and wire rope bonder. All velocity power tools derive their actuating force from powder cartridges similar to rifle cartridges ex-



PLATE 104.—Velocity power pipe bonding press.

cept that the cartridge contains only the powder. The velocity projectile or moving part is an integral part of the tool. Plates 104, 105, and 106 show the pipe bonder, power driver, and cable cutter tools.

The velocity power driver is useful in quickly attaching steel plates by driving studs in the base and by inserting the plate over the studs through holes previously punched in the plate by the driver. The plate can then be securely attached to the base by nuts after which welding may be accomplished if a more permanent attachment is desired. In addition to driving studs and punching holes, the driver can be used for rivet removing by changing the type of projectile head.

The velocity power cable cutter is capable of cutting wire cable up to 1 inch diameter. Characteristic of many of these tools, the cable cutter can function on the surface or under water.

The pipe press is used for bonding or coupling steel, iron, brass, or copper pipes together without the use of threaded connections

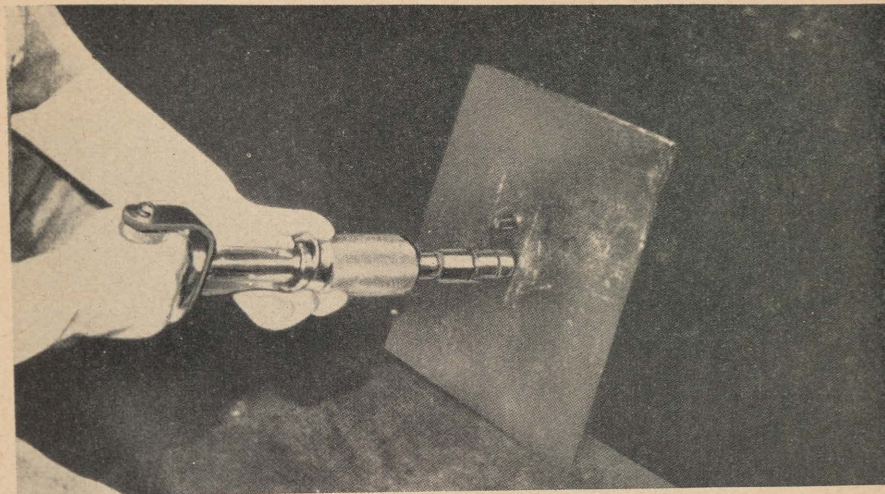

PLATE 105.—Velocity power driver.

ranging in sizes from  $\frac{3}{8}$ -inch pipe to 1-inch pipe. A plain coupling of an internal diameter slightly larger than the external diameter of the pipe to be coupled is slipped over the ends of the pipes and the pipe press is placed in operating position. On firing the blank cartridge, the coupling is compressed over the pipe to the extent that the coupled fitting can withstand an internal hydrostatic pressure of at least 4,000 pounds per square inch. The pipe press is designed for surface work only.

The wire rope press is similar in principle to the pipe press except that the former is used to attach fittings (eyes, couplings, etc.) to wire rope. The completed attachment is capable of withstanding forces equal to at least 95 percent of the breaking strength of the rope. Similar to the pipe press, the wire rope press is designed for surface work only.

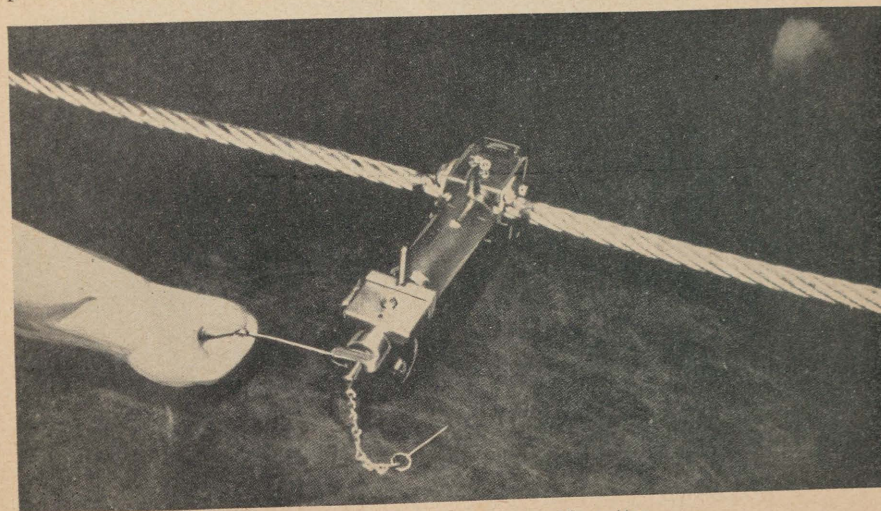

PLATE 106.—Velocity power cable cutter.

The rivet remover is similar to the driver except that attachments are provided for exactly centering the apparatus over the rivet to be removed. This device is capable of removing countersunk, buttonhead, and panhead rivets in sizes from  $\frac{5}{8}$  inch to 1 inch from fabricated steel structures. The performance is rapid and complete and no difficulty is experienced in removing the driving unit from the hole and preparing for the next operation. This unit is designed for surface work only.

The rivet expander can be used for surface or underwater work operating equally well in either case. The principle of operation is similar to the driver except that the projectile is a small tapered pin which is fired into the head of the rivet, tending to increase the diameter of the head and upper body approximately 0.03 inch.

Detailed instructions in the operation, care, and maintenance are furnished with each velocity power tool.

The purpose of the washing nozzle and lance is to create a tunnel or passage under the submarine through which are reeved the large lifting chains that are attached to the pontoons. Water under great pressure is supplied to the nozzle or lance where it is directed at the bottom at great velocity. The force of the water stream dislodges the mud and silt and the flow of water from the nozzle carries it clear of the washing operation

Washing  
nozzles and  
lances.

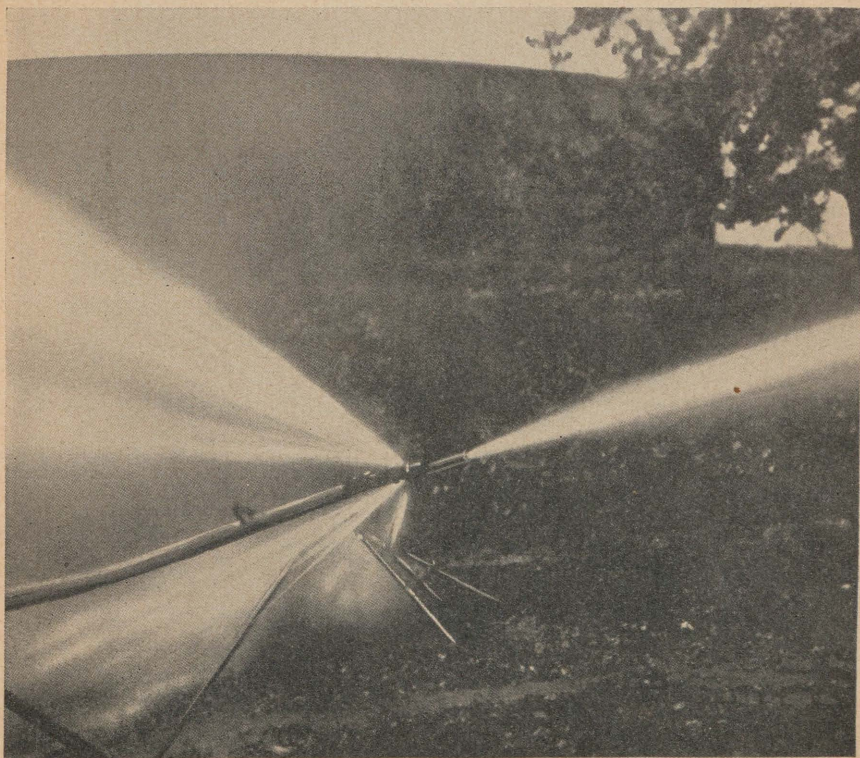

PLATE 107.—Washing nozzle—Falcon type.

The washing nozzles similar to the type shown in plate 107 were used in the *S-51* and the *S-4* submarine salvages but were found unsatisfactory for tunnelling purposes during the *Squalus* salvage due to the character of the bottom in which the submarine was partially imbedded.

During the *Squalus* salvage, a lance was developed consisting of a washing nozzle attached to lengths of curved  $1\frac{1}{4}$ -inch pipes joined by ordinary pipe unions. An attempt was made to force the lance under and around the submarine. The original lance was not satisfactory as it was nearly impossible to retain correct alinement by using the ordinary pipe unions and it was also difficult for the diver to make union between the sections. After the lance passed the keel of the submarine, the washing water tended to escape on the far side, permitting silt and mud to settle around the lance and prevent further advancement. After the first unsuccessful attempt the lance shown in plate 108 was developed which eliminated the deficiencies of the original type. The lance was made up of self-alining telescopic joints with four backwardly directed holes every 4 feet of length to provide reaction jets to assist in advancing the lance and to keep the lance cleared of mud and silt. A fire hose was connected to the rear end of the lance for the high-pressure water supply and the lance was forced under and around the submarine, with divers attaching additional sections when necessary. After the nozzle of the lance appeared on the opposite side of the submarine, a small steel rod was passed through the lance to which a wire rope was attached. Progressively larger wire ropes were rove through the lance, and the lifting chains were eventually pulled under the submarine after the lance had been disassembled and removed.

The use of this type of lance is restricted to bottoms of mud or sand and cannot be used on rocky or gravelly bottoms.

Submarine rescue vessels carry an allowance of one of the above lances. In the event of an emergency the lance can be constructed as outlined in C. & R. drawing No. 365240, a copy of which is carried on board. The diameter of curvature of the lance is dependent upon the type of submarine and the longitudinal location on the submarine for the lifting chains. The construction of the lance is relatively simple and any navy yard can construct same in 48 hours after receipt of plans.

Cement guns are used to seal hatches or other openings with a cement which normally hardens in approximately 24 hours. The gun is composed of a large steel cylinder having a cement outlet hose on the bottom and an air inlet hose on top and is further equipped with small petcocks in the cylinder wall to ascertain the level of the cement in the gun. The cement is forced from the gun by compressed air and is led to the desired location through a suitable length of hose. In sealing underwater spaces it is necessary to have this sealing space suitably protected by canvas or other material to prevent water currents, etc., from washing the cement away as soon as it is deposited. It is further necessary to use the cement soon after it is mixed and to clean out the gun and hose thoroughly as soon as possible after using. In forcing the cement through the hose, care should be taken not to deplete

Cement guns.

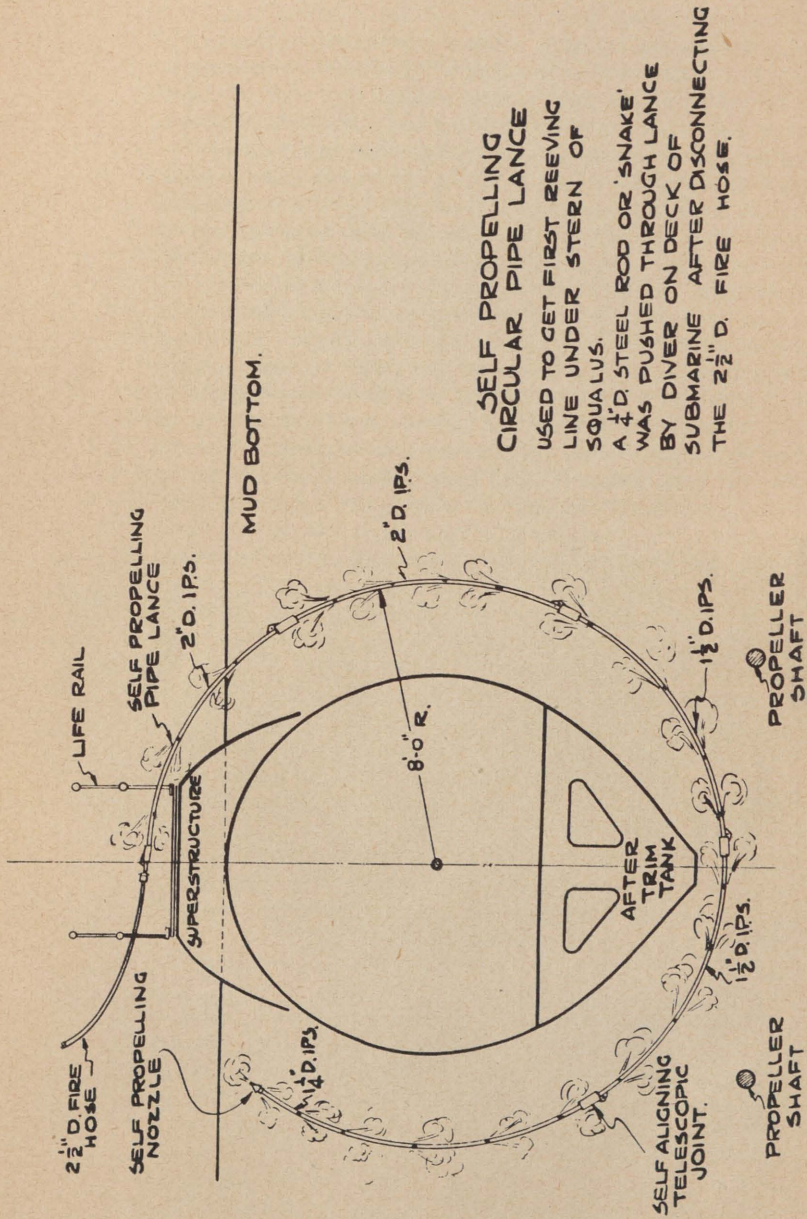

PLATE 108.—Self-propelling circular pipe lance.

the entire cement supply as air will then rush through the hose with such force as to displace the cement from the sealing space. A cement gun of this type is shown on plate 109.

**SECTION III. NOTABLE SALVAGES**

The *F-4* sunk in 306 feet of water off Honolulu on March 25, 1915, during normal operations. The cause of the sinking was never definitely ascertained. Salvage operations were begun immediately upon locating the wreck and the submarine was soon

Salvage of the *F-4*.

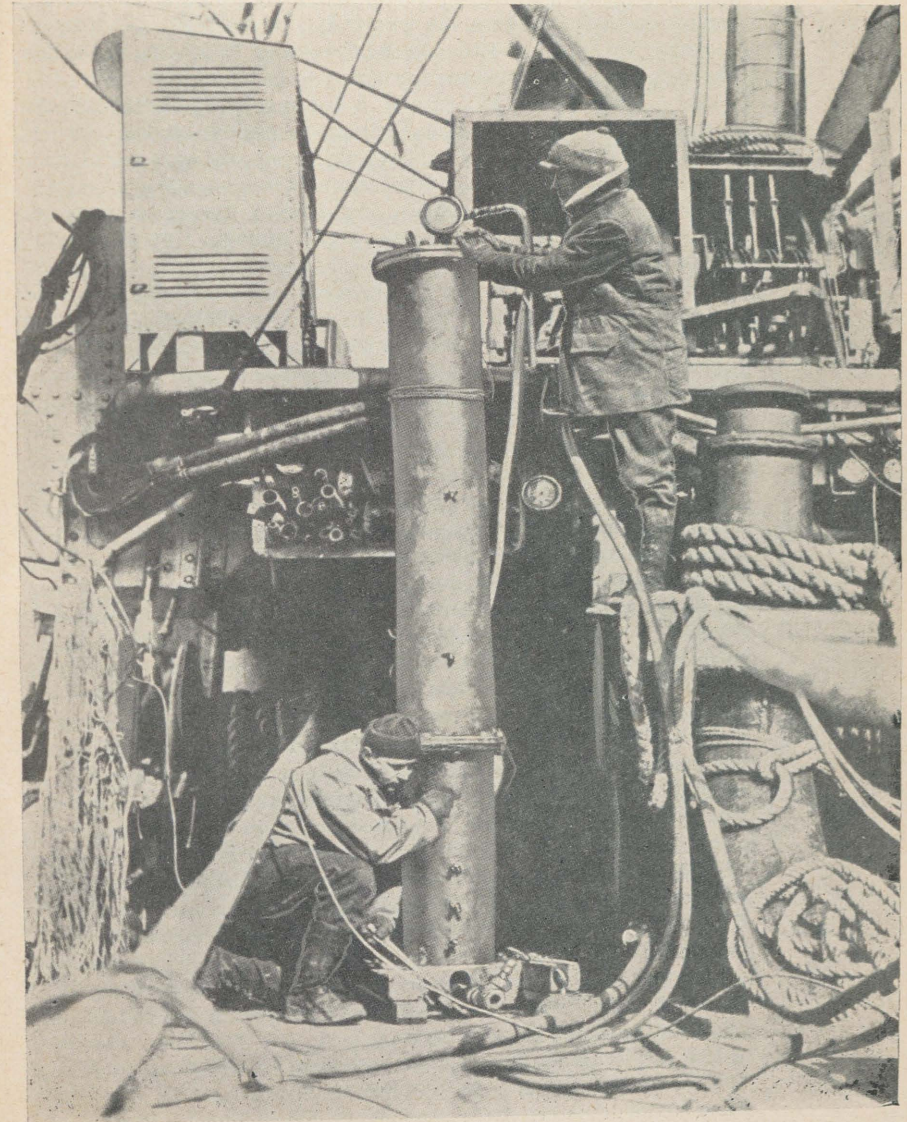

PLATE 109.—Cement gun.

moved into shallow water (40 feet) by sweeping wires under the bow and stern and lifting by the use of winches installed on scows. Six pontoons were then constructed to provide the lifting force in the last stage. These pontoons were 32 feet in length by 11 feet in diameter weighing 35 tons and giving a lifting force of approximately 60 tons when completely submerged and entirely free of water. The pontoons were submerged, three on each side of the vessel, connected in opposite pairs by two chains swung underneath the *F-4*. When everything was in readiness, the pontoons were blown clear of water by compressed air thus causing approximately 360 tons of lifting force to be exerted on the *F-4*, raising her to the surface where she was towed to drydock. No internal buoyancy was utilized either in the first stage in moving to shallow water or in the second stage in raising to the surface.

The salvage of the *F-4* is one of the most noteworthy salvage undertakings ever conducted. Diving to depths of 300 feet was theretofore unheard of and the actual salvaging of a vessel from such a depth was considered impossible. Undaunted by the apparently unsurmountable hazards, the United States Navy force tackled the problem with a grim determination that eventually spelled success after 4 months of exhausting efforts, in spite of many disheartening reverses from wind, weather, and tide, and insufficient material both in quality and quantity. The diving record of 306 feet stood for many years as the deepest depth ever attained by man using regular diving equipment.

The *F-4* was of approximately 275 tons displacement carrying a crew of 21 officers and men at the time of the disaster. All hands were lost as there were no rescue devices provided for such purposes at that date.

The *S-51* was acting as a surface vessel on September 25, 1925, off Block Island when rammed by the steamship *City of Rome*. All ventilation valves and ducts were open as the submarine was navigating on the Diesel engines, and consequently nearly all or all of the main compartments were immediately flooded causing the *S-51* to sink in 132 feet of water. Salvage operations commenced on October 14, 1925, extending throughout the winter and spring with intermittent delays and suspension of operations due to rough water and cold weather. The *S-51* was finally raised on July 5, 1926, and towed to New York harbor where she went aground on Man of War Rock. The *S-51* was refloated a few days later and finally came to rest in drydock at the New York Navy Yard on July 9, 1926.

The raising of the *S-51* was accomplished by using pontoons to provide external buoyancy and the dewatering of all available compartments of the submarine to provide internal buoyancy. The character of the bottom necessitated the use of washing nozzles to tunnel under the *S-51*, thus creating an opening through which the pontoon lifting chains were passed under the wreck. The basic principles of this method of salvage are described under the Salvage of the U. S. S. *Squalus*.

The *S-51* had a submerged displacement of approximately 1,230 tons and was operating with a crew of 36 officers and men at the time of the disaster. Four men who were on watch in the conning

Salvage of  
the *S-51*.

tower were thrown overboard by the collision and six escaped from the submarine through the conning tower hatch as the vessel was sinking, but only three of the latter were eventually picked up and saved.

The *S-4* was emerging to the surface off Provincetown, Mass., on Saturday December 17, 1927, when struck by the U. S. Coast Guard Cutter *Paulding*. The submarine rolled to port upon collision and sank in 102 feet of water. Rescue operations began at once but were forced to terminate December 24, 1927, when no further signs of life were perceived. Salvage operations were commenced immediately with the U. S. S. *Falcon* serving as the salvage and diving vessel. The method of raising was practically the same as that used in salvaging the *S-51*. The *S-4* was finally raised on March 17, 1927, and then towed to the Boston Navy Yard for reconditioning.

The *S-4* had a submerged displacement of approximately 1,060 tons. None of the 40 officers and men on board at the time of the collision were saved.

The U. S. S. *Squalus* was on builders' diving trials off Portsmouth, N. H., on May 23, 1939, when an emergency dive was attempted. The indicator panel signified that all valves and openings affecting the watertight integrity of the hull were closed and that in all other respects the submarine was in full preparedness for the dive. However, upon submerging, water entered the main ventilation duct through the main engine outboard induction valve and entered the four after compartments through the hull valves controlling the air inlet to these compartments. None of these valves could be closed against the inrush of water and the submarine immediately sank stern first in 240 feet of water. All personnel (26) in the after four compartments were immediately drowned and the 33 men in the control room and forward battery and torpedo room were trapped in the sunken submarine.

Suspicious of disaster were aroused when radio communication could not be established with the *Squalus* at a time when her dive should have been completed. The commandant of the Portsmouth Navy Yard immediately ordered the U. S. S. *Sculpin* to conduct a search and further ordered the U. S. S. *Falcon* to stand by prepared for rescue operations.

The *Sculpin* soon located a red smoke bomb indicating the presence of the sunken submarine and telephone communication was soon established through the marker buoy. Telephone communication was broken off due to the parting of the cable but the conditions in the *Squalus* had already been ascertained and rescue operations commenced immediately.

Of first concern was the saving of the personnel trapped in the forward compartments of the *Squalus*, after verification of the assumption that all persons in the flooded four after compartments had perished. Communication with the *Squalus* had indicated that sufficient oxygen and CO<sub>2</sub> absorbent was available on board to permit rescue operations by the use of the rescue chamber. The downhaul cable was attached to the escape hatch by a diver and the first trip was soon completed bringing seven

Salvage of  
the *S-4*.

Salvage of  
the *Squalus*.

persons to the surface. All went well until the fourth and last trip when the downhaul cable jammed and the occupants were forced to remain submerged for 4 hours until the cable was cleared. The success of the rescue chamber was amply demonstrated in saving all entrapped personnel at this excessive depth.

With rescue operations terminated, salvage operations commenced immediately and continued diligently day and night until completed. The *Falcon* was designated as the salvage and diving vessel and other vessels were assigned as attendant vessels.

Examinations by divers revealed that the four compartments aft were totally flooded and that the forward three compartments were nearly empty of water. The *Squalus* had a trim of approximately 10° by the stern with the after part nearly buried in mud.

Many salvage plans were considered and finally a pontooning arrangement similar to that shown in plate 110 was agreed upon.

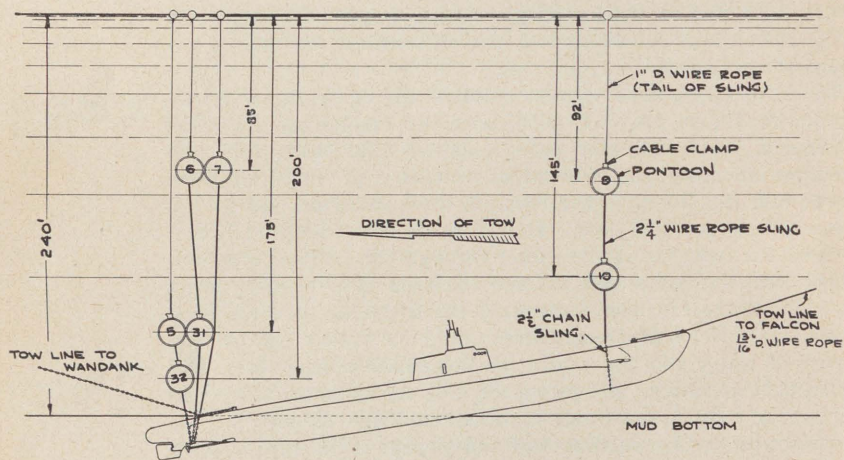

ARRANGEMENT OF PONTOONS  
LIFT OF 13 JULY, 1939  
SCALE:  $\frac{1}{50}'' = 1'-0''$

PLATE 110.—Salvage of U. S. S. *Squalus*—arrangement of pontoons.

The forward pontoon chains and cables were swept under the bow and abaft the bow planes while the stern chains and wires were reeved under the stern by the use of the lance. The first lance proved unsuccessful but the improved lance made a successful turn under the hull and permitted the passage of a small flexible steel wire to which were attached wires of increasing diameters, and finally the pontoon chains were reeved through after the lance had been disassembled.

Pontoons were lowered and secured, air hoses attached, and salvage air lines attached to the submarine's ballast and fuel tanks. The first attempt to raise the submarine proved unsuccessful as insufficient pontoons were placed at the upper level. This caused the bow to rise to the surface and allowed air to escape from the ballast tanks. The excessive angle permitted sufficient reflooding which destroyed the positive buoyancy and resulted in the bow again settling to the bottom. Rearrangement of pontoons to agree with the first position shown in plate 111 proved satisfactory, and on August 12 the stern was raised until the upper pontoons broke surface after which further

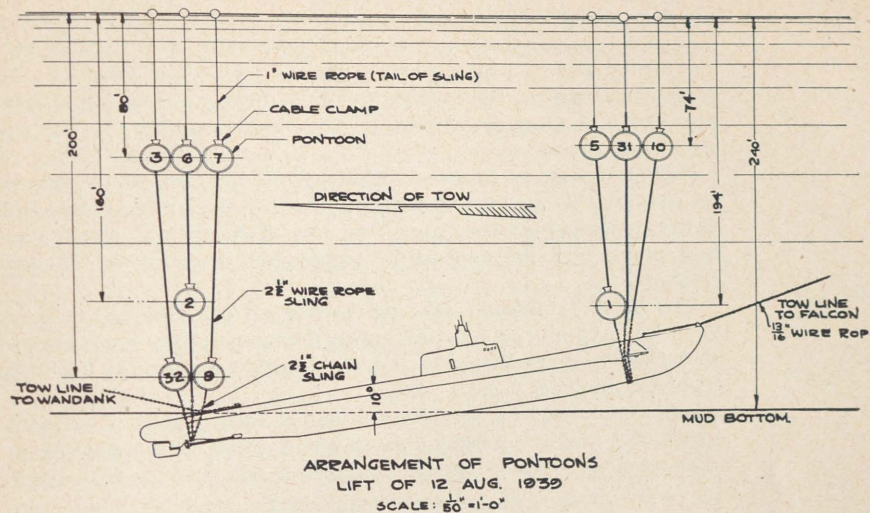

ARRANGEMENT OF PONTOONS  
LIFT OF 12 AUG. 1939  
SCALE:  $\frac{1}{50}'' = 1'-0''$

PLATE 111.—Salvage of U. S. S. *Squalus*—arrangement of pontoons.

blowing of tanks and forward pontoons caused the bow pontoon to surface. The vessel was then towed stern first to shallower water where she grounded at a depth of 160 feet aft and 180 feet forward. The pontoons were rearranged as indicated by the second position in plate 112 and a second lift was successful by the same process, followed by towing to shallower water where the *Squalus* grounded in 92 feet of water. After several unsuccessful attempts to raise by using internal buoyancy alone, two pontoons were attached longitudinally parallel to the hull at the stern and two at the bow as close to the *Squalus* as practicable. The main outboard air induction valve was closed and all compartments and pontoons blown free of water causing the final raising of the vessel and subsequent towing to the Portsmouth Navy Yard where she was drydocked on September 15, 1939.

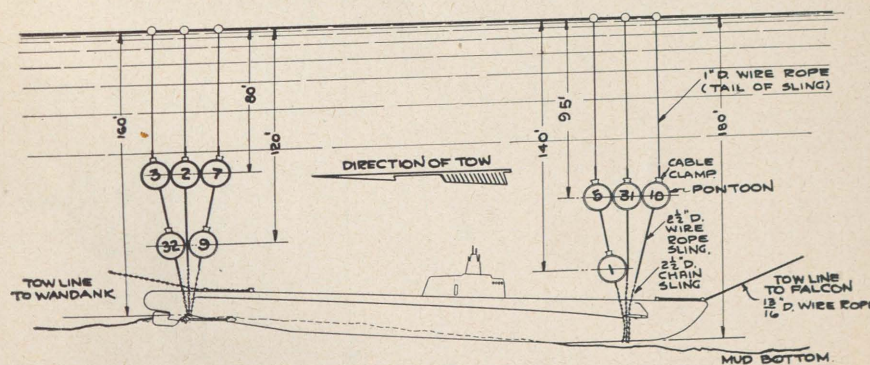

ARRANGEMENT OF PONTOONS  
LIFT OF 17-AUG, 1939  
SCALE:  $\frac{1}{50}'' = 1'-0''$

PLATE 112.—Salvage of U. S. S. *Squalus*—arrangement of pontoons.

Six hundred and forty dives had been conducted during rescue and salvage operations at the *Squalus* without loss of life or serious injury, 302 of which were in depths exceeding 200 feet. Air alone was used as the respiratory gas during rescue operations, but oxygen-helium mixtures proved indispensable in the salvage operations.

Notable advances in rescue and salvage gear were the successful rescue of all entrapped personnel by the use of the rescue bell, the development of the lance, the use of multilevel pontoon arrangement, and the success of oxygen-helium mixtures in deep diving.

The U. S. S. *Omaha* was proceeding to the Charleston Navy Yard for overhaul at approximately 15 knots when she grounded upon Castle Island Reef, British West Indies, during the darkness of the morning of July 19, 1937.

Prior to grounding, the *Omaha* had a mean draft of approximately 16½ feet, corresponding to about 9,000 tons displacement. After grounding, the forward draft was 7 feet and the after draft

Salvage of  
the *Omaha*

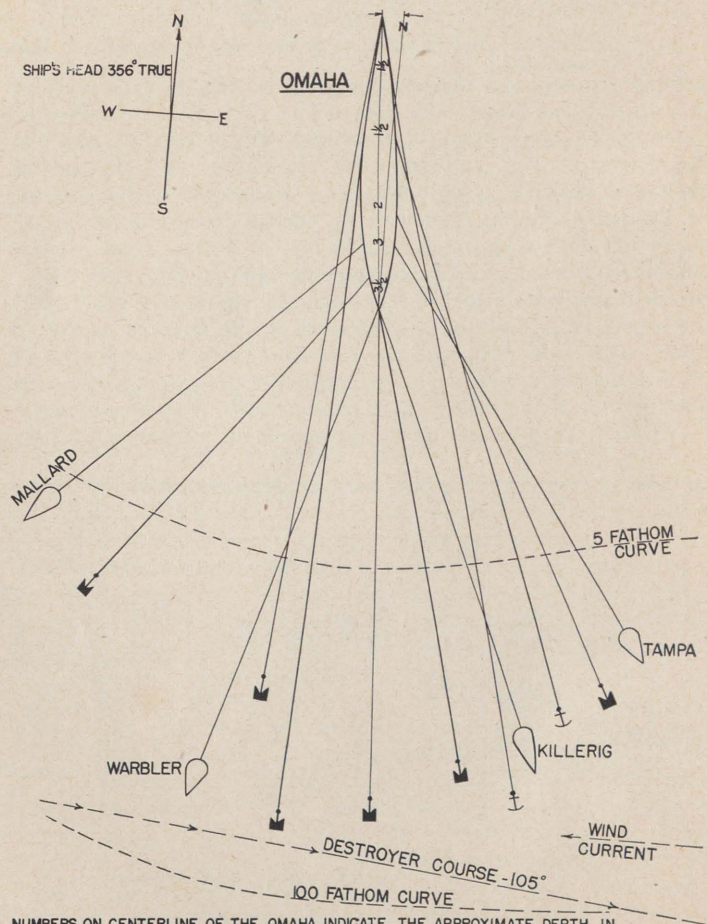

PLATE 113.—Arrangement of salvage gear used on salvage of U. S. S. *Omaha*.

was 17½ feet, corresponding to a displacement of about 6,450 tons and signifying that the *Omaha* was grounded by a weight equal to about 2,650 tons.

The reef was a slightly sloping ledge of white coral which dropped off sharply to 100 fathoms at about 2 ships' lengths abaft the stern. The forward half of the vessel was in contact with the reef, the impact having crushed the forward bottom up a slight amount but without any serious flooding.

Repeated attempts were made to float the vessel by sallying ship and by the use of beach gear after stores, ammunition, fuel, etc., had been removed by barges and lighters, but all early attempts proved of no avail.

Additional weights were removed until approximately 1,650 tons had been removed leaving an estimated negative buoyancy of approximately 1,000 tons. On July 28, another attempt was made using eight beach gear laid out astern coupled with the towing force of four vessels astern. During the strain, destroyers raced by near the stern creating a wave motion capable of rolling the *Omaha* and thus assisting in setting her in motion. The combined force resulted in moving the vessel a distance of approximately 25 feet on the first pull and later in the day an additional distance of 40 feet was attained. On July 29, similar operations resulted in the floating of the *Omaha* exactly 10 days after grounding.

After taking on fuel and supplies the *Omaha* proceeded under her own power to Norfolk where she was drydocked and reconditioned.

Plate 113 indicates the arrangement and the number of salvage gear used.

## CHAPTER XX

### GLOSSARY OF TERMS

*Alveolar air.*—The air contained in the somewhat enlarged terminal sections of the bronchioles whose walls are beset with air cells, through which the gaseous exchange in the air and blood take place (see Trachea).

*Aphasia.*—Total or partial loss of the use of or understanding of language, the vocal cords remaining intact. Any of the qualities or varieties of communication may be affected, both spoken and written. It results from injury or disease of the brain.

*Arteriosclerosis.*—Abnormal thickening and hardening of the walls of the arteries, especially of the intima (innermost coat), occurring naturally in old age.

*Artificial respiration.*—Induced respiration by artificial means as with the Schaffer method.

*Asphyxia.*—Apparent death or suspended animation, in living organisms due to deficiency of oxygen or an excess of carbon dioxide in the blood, as interruption of respiration from suffocation or drowning, or from inhalation of irrespirable gases.

*Caisson.*—A watertight box or chamber within which submarine construction is carried on under air pressure to keep out the water. The diving suit may be likened to a caisson.

*Capillary.*—A minute, thin-walled vessel, as the smallest lymphatic and biliary vessels; especially one of the minute blood vessels (the smallest barely permitting the passage of the blood corpuscles) which form networks in nearly all parts of the body. They are continuous with the minute branches of the arteries and with those of the veins, and are in most parts of the body the only communication between the arteries and veins. Capillaries consist of a single layer of endothelial cells. Through these walls the tissues absorb the nutriment and oxygen from the blood and discharge their waste into it.

*Central nervous system.*—That part of the nervous system to which the sensory impulses are transmitted and from which the motor impulses pass out; in vertebrates, the spinal cord and brain.

*Cerebral.*—Of or pertaining to the cerebrum, or hemispheres of the brain.

*Compression.*—Subjection of workmen to compressed air.

*Concomitant.*—That which accompanies, or is collaterally connected with, another; an accompaniment.

*Decompression.*—Release of excess air pressure from a workman, as, for example, in an air lock on returning to the outside air from a caisson under compressed air.

*Dermatitis.*—Inflammation of the derma or true skin.

*Diminution.*—Reduction in size, quantity, or degree; reduction.

*Dyspnea.*—Difficult or painful breathing.

*Eardrum.*—The tympanum or tympanic membrane of the ear.

*Ecchymosis.*—A livid or black and blue spot produced by the extravasations or effusion of blood into the alveolar tissue.

*Embolism.*—The occlusion of a blood vessel by an embolus. Embolism in the brain often produces sudden unconsciousness and paralysis.

*Embolus.*—A plug brought by the blood current and lodged in a blood vessel so as to obstruct the circulation. It consists usually of a clot of fibrin, a shred of a morbid growth, a globule of fat, air bubbles, or a micro-organism.

*Epiphysis.*—A part or process of a bone which ossifies separately and subsequently becomes ankylosed to the main part of the bone. In the higher vertebrates the ends of long bones of the limbs are formed in this way, and in man in some cases do not unite with the diaphysis, or shaft of the bone, until about the twentieth year.

*Erythema.*—A morbid redness of the skin of many varieties due to congestion of the capillaries; rose red rash.

*Exigency.*—Urgent or exacting want; pressing necessity; a case demanding immediate action.

*Eustachian tube.*—A channel of communication between the tympanic cavity of the ear and the pharynx. In man the Eustachian tubes are about 1½ inches long, with walls of bone, cartilage, and fibrous tissue. They open into the upper back part of the pharynx, each side of the median line, and serve to equalize the air pressure on both sides of the tympanic membrane.

*Extremity.*—A limb of the body, as the arm or leg.

*Exudate.*—Exuded matter.

*Exude.*—To discharge through pores or incisions, as moisture or other liquids; to give out.

*Gastric.*—Of or pertaining to the stomach.

*Heat conduction.*—Heat may be conveyed by conduction as along an iron rod; by convection as through the rooms of a house by air currents; or by radiation, as from the sun to the earth.

*Hemiplegia.*—A paralysis that affects one side only of the body.

*Inferior extremities.*—Lower limbs, including thigh, leg, and foot.

*Inodorous.*—Emitting no smell; scentless; odorless.

*Irrespirable.*—Unfit for respiration; not respirable (so as to sustain life).

*Irritant.*—Any agent by which irritation or inflammation is produced, as a chemical or mechanical irritant.

*Labyrinth.*—The internal ear or its bony or membranous part, so called from its complex structure.

*Larynx.*—The modified upper part of the trachea. In man it is the organ of voice. The framework of the human larynx consists of nine cartilages controlled by numerous muscles. The largest cartilage, the thyroid, is V-shaped in horizontal section, its point making the protuberance on the front of the neck, known as Adam's apple.

*Lesion.*—A hurt; an injury; any morbid change in exercise of function or texture of organs.

*Liter.*—A measure of capacity in the metric system, being a cubic decimeter equal to 61.022 cubic inches, or 1.0567 U. S. liquid quarts.

*Monoplegia.*—A paralysis affecting a single limb or part of the body.

*Moribund.*—In a dying state: near death.

*Motor.*—Designating or pertaining to a nerve or nerve fiber, which passes from a ganglion or from the central nervous system to a muscle and by the impulse (motor impulse) which it transmits causes movement. The term is often loosely applied to an efferent nerve as opposed to a sensory or afferent nerve.

*Noxious.*—Hurtful; harmful; painful; destructive; unwholesome.

*Paralysis.*—Abolition of function, whether complete or partial; especially the loss of the power of voluntary motion or of sensation in any part of the body; palsy.

*Paraplegia.*—Paralysis in the lower half of the body on both sides. Usually due to disease of the spinal cord.

*Partial pressure of a gas.*—The pressure of any individual gas in a mixture of gases. It is the same as that which the gas would exert were it confined alone in the space occupied by the mixture; called also Dalton's law.

*Patulousness.*—State of being open.

*Pharynx.*—The part of the alimentary canal between the cavity of the mouth and the esophagus (gullet). In man it is a conical musculo-membranous tube about  $4\frac{1}{2}$  inches long, continuous above with the mouth and nasal passages, communicating through the Eustachian tubes with the ears, extending downward past the opening in the larynx, where it is continuous with the esophagus.

*Phlegmatic.*—Sluggish; not easily excited; cool; calm; composed.

*Physics.*—That branch of science dealing with the material world; natural philosophy. With the growth of science various parts of this field, as biology, chemistry, astronomy, and geology, gradually were excluded. Now physics is usually held to comprise the closely related sciences of mechanics, heat, electricity, light, and sound, and to deal only with those phenomena of inanimate matters involving no changes in chemical composition. Motion is the most general and fundamental of all such phenomena, and physics is sometimes defined as the science of matter and motion.

*Pneumonia.*—Inflammation of the lungs. Lobar involvement of a lobe or lobes (large areas). Broncho or catarrhal involvement of lobules or small areas. General; involvement of both lungs in their entirety.

*Ponderable.*—Capable of being weighed; having appreciable weight.

*Potassium hydrate.*—A white deliquescent solid KOH, dissolving with much heat, in less than its weight of water, forming a strongly alkaline and caustic liquid; caustic potash. It absorbs carbon dioxide from the atmosphere.

*Prognosis.*—Act or art of foretelling course and termination of a disease; also, the outlook afforded by this.

*Pyelitis.*—Inflammation of the pelvis or the kidney.

*Recompression.*—To subject a workman to compression after being decompressed.

*Recumbent.*—Reclining, lying, as a recumbent posture.

*Respiration.*—Act or process of breathing; inspiration and expiration; the drawing of air into the lungs for oxygenating and purifying the blood, and its subsequent exhalation. The term designates both a single inspiration with the following expiration, and the continued repetition of these acts, which constitutes breathing. In ordinary inspiration the muscles chiefly used are the diaphragm, which enlarges the capacity of the chest by becoming flatter as it contracts and pressing down the abdominal viscera, and the external intercostals, levatores costarum, and others which raise the ribs. Expiration, unless forced, takes place chiefly by the return of the parts to their natural position of rest. But a small part of the total air in the lungs is replaced in an ordinary respiration.

*Sensory.*—Of or pertaining to the sensorium or sensation, as sensory impulses; especially applied to nerves and nerve fibers carrying to a nerve center impulses resulting in sensation; also sometimes loosely used in the sense of afferent, to indicate nerve fibers conveying any impressions to a nerve center. Of the nature of sensation; pertaining to sense. (See *Motor*.)

*Solution.*—The act or process by which a substance, whether solid, liquid, or gaseous, is absorbed into and homogeneously mixed with another liquid substance; also, the resulting liquid product. Any homogeneous mixture (usually liquid), the composition of which can undergo continuous variation within certain limits; sometimes called physical mixture. Also, the act or process by which such mixture is produced.

*Specific gravity.*—The ratio of the weight of any volume of a substance to the weight of an equal volume of some other substance taken as the standard unit; relative density; this standard is usually water for solids and liquids, and air for gases. Thus, 19, the specific gravity of gold, expresses the fact that, bulk for bulk, gold is nineteen times as heavy as water. In the case of gases, usually the weights of equal volumes at 0° centigrade and 760 mm. are compared.

*Specific heat.*—The ratio of the quantity of heat required to raise the temperature of a body 1° to that required to raise an equal mass of water to 1°. Also, the heat in calories required to raise the temperature of 1 gram of a substance 1° centigrade.

*Staggers.*—A cerebral and spinal disease, attended by reeling, unsteady gait, or sudden falling.

*Subcutaneous.*—Situated beneath the skin.

*Tendon.*—A tough cord or band of dense, white fibrous connective tissue uniting a muscle with some other part and transmitting the force which the muscle exerts; a sinew. Tendons, except in the largest, are very sparingly or not at all supplied with nerves or blood vessels, and are continuous with the connective tissue sheaths of the muscle and, when inserted into a bone, with the periosteum of the bone.

*Tetanic.*—Having the character of tetanus. This condition of muscle, this fusion of a number of simple spasms into an apparent smooth continued effort is known as tetanus, or tetanic contraction.

*Tissue.*—An aggregate of cells together with their intercellular substance, forming one of the structural materials out of which the body of a plant or an animal is built up.

*Trachea.*—Windpipe; in vertebrates, the main trunk of the system of tubes by which air passes to and from the lungs; in man it is about 4 inches long and somewhat less than an inch in diameter, and extends down the front of the neck from the larynx, bifurcating to form the bronchi. It has walls of fibrous and muscular tissue, stiffened by incomplete cartilaginous rings, which keep it from collapsing, and is lined with mucous membrane, whose epithelium is composed of columnar ciliated and mucus-secreting cells. The bronchi divides into bronchioles, which continue to divide and subdivide.

*Tubercular.*—Of or pertaining to tuberculosis; an infectious disease, the exciting cause of which is the tubercle bacillus and which is characterized by the production of tubercles; specifically, this disease when seated in the lungs; pulmonary phthisis, or consumption.

*Tympanites.*—A distension of the abdomen; due to air or gas accumulating in the intestinal tract or peritoneal cavity.

*Vertigo.*—Dizziness, or swimming of the head; an affection of the head in which objects, though stationary, appear to move in various directions, and the person affected finds it difficult to maintain an erect posture. It results from changes in the blood supply to the brain and often precedes attacks of epilepsy or cerebral hemorrhage.

## INDEX

	Page
Absolute pressure.....	127
Accidents, diving.....	191
Accumulators.....	140
High pressure.....	140
Low pressure.....	141
Precautions in supplying air from.....	126
Air.....	157
Air bubbles, observation of and prevention of diver from falls.....	114, 143
Air compressors, gasoline driven.....	89, 119
Air control valve.....	128
Air, diving, temperature of.....	191
Air embolism.....	44
Air hose, diver's.....	114
Air hose diving.....	45
Air hose reducers.....	141
Air flasks, precautions in supplying air from.....	138
Air flasks, torpedo.....	131
Air from diving pump, diving with.....	65
Air manifolds, diver's.....	138
Air plants.....	141
Air, precautions in supplying from accumulators and air flasks.....	32
Air pump pressure gages.....	65, 141
Air pumps, diving.....	132
Air pumps in motor launches.....	141
Air pumps, manually operated, precautions in using.....	109
Air regulating escape valve, care of.....	158
Air supply adjustment.....	152
Air supply and helmet ventilation.....	239
Air supply compressed.....	145
Air supply, dehydration of.....	137
Air supply, diver's (normal air).....	144
Air supply, general.....	116
Amplifier, care of.....	85
Amplifier equipment, diving.....	84
Amplifier type diving telephones.....	162
Anchor, recovery of.....	129
Arranging and planning diving.....	149
Arranging gear for diving from ship's deck.....	150
Arranging gear in diving launch.....	168
Ascent.....	156
Ascents, emergency.....	235
Ascent when using oxygen-helium.....	192
Asphyxia.....	126
Atmospheric pressure.....	261

	Page
Attendants, instructions to.....	172
Batteryless type diving telephone.....	82
Belt, weighted.....	18
Care of.....	106
Bleeding from nose and lungs.....	193
Blowing up.....	193
Box for pump piston leathers.....	18
Box for spare parts.....	23
Boyle's law.....	124
Breathing.....	137
Buoyancy.....	127
Buoys.....	23
Cable, combination telephone and life line.....	24
Caisson disease.....	181
Cause.....	181
Prevention.....	182
Symptoms.....	182
Treatment.....	181
Carbon dioxide.....	125
Cardiovascular system, qualifications of divers.....	12
Care, survey, and requisition of diving gear.....	104
Cement guns.....	247
Charles law.....	124
Chests, helmet and outfit.....	25
Collar, repair of.....	107
Communication when using oxygen-helium.....	235
Compressed air illness.....	181, 194
Compressed air in motor launches, use of.....	132
Compressed air supply.....	239
Cuffs.....	29
Attaching of.....	107
Curriculum, diving school.....	2
Cushion, helmet.....	25
Cutting and welding outfits, underwater.....	242
Decompression, alternative for emergencies.....	212
Decompression following blow up by diver using oxygen-helium.....	214
Decompression in diving launch dives.....	175
Decompression, oxygen-helium.....	201
Decompression stages.....	77
Decompression surface, oxygen-helium.....	213
Deeper diving by use of oxygen-helium mixture.....	200
Descent.....	152
Precautions in.....	152
Descent and on bottom, procedure during, with oxygen-helium.....	235
Development of diving.....	1
Disease, caisson.....	181
Disqualifying diseases, qualification of divers.....	12
Distance line, loss of.....	166
Diver's air hose.....	44
Diver's air supply (normal air).....	137
Divers, instructions to.....	174
Diver's knives.....	46

	Page
Divers, physical qualifications of.....	10
Age.....	10
Cardiovascular system.....	12
Diseases, disqualifying.....	12
Gastrointestinal system.....	12
Habits.....	12
Height and weight.....	10
Mental ability.....	11
Respiratory.....	12
Temperament.....	11
Vision.....	12
Diver's tool bag.....	18
Dives, duration of.....	131
Dives, repeated.....	172
Diving accidents.....	191
Diving amplifier equipment.....	85
Diving dress.....	29
Diving gear, care, survey, and requisitioning of.....	104
Diving gear, navy standard, description of.....	18
Diving helmet.....	34
Diving ladder.....	49
Diving outfits, Navy standard.....	15
Allowance list.....	16
Types.....	15
Diving, planning and arranging.....	129
Diving, reexamination prior to.....	13
Diving school.....	2
Curriculum.....	3
Eligibles.....	2
Facilities.....	9
Faculty.....	2
Diving unit, experimental.....	1
Diving with air from diving pump.....	131
Diving with helmet only.....	177
Dress, diving.....	29
Care of.....	106
Dressing the diver diving from launch.....	150
Dressing the diver diving from ship's deck.....	149
Dressing the diver using oxygen-helium.....	234
Drowning.....	194
Dry-cell type diving telephones.....	82
Duration of dives.....	131
Ear pains.....	152, 195
Eligibles, diving school.....	2
Embolism, air.....	191
Exhaustion.....	197
Experimental diving unit.....	1
Facilities, experimental diving unit and diving school.....	9
Faculty, diving school.....	2
Falls, guarding against.....	163
Fouled diver.....	165
Fouling.....	197
Gage pressure.....	127

	Page
Gas analysis apparatus, Haldane-Henderson.....	217
Gasoline driven air compressor.....	114, 143
Gasoline driven air compressor in motor launches, use of.....	132
Gastrointestinal system, qualifications of divers.....	12
Gear, diving, inspection of.....	105
General qualifications of divers.....	10
Glove repair.....	108
Gloves, attaching of.....	107
Gloves, combination diver's and tender's.....	32
Gloves, woolen.....	32
Group relay diving.....	130
Haldane-Henderson gas analysis apparatus.....	217
Helium and oxygen, mixing of.....	214, 215
Helium flasks, splitting.....	215
Helium, quality of.....	215
Helium, source of.....	214
Helium, substitute for nitrogen.....	200
Helmet and breastplate, care of.....	108
Air regulating escape valve.....	109
Safety valve, care of.....	109
Helmet and outfit chests.....	25
Helmet cushion.....	25
Helmet, diving.....	34, 177
High pressure accumulators.....	140
History, oxygen-helium.....	200
Hydrogen.....	125
Injuries, mechanical.....	197
Inspection of diving gear.....	105
Instructions to—	
Attendants.....	172
Divers.....	174
Knives, divers'.....	46
Ladder, diving.....	49
Lances, washing nozzles and.....	246
Leaks, minor.....	164
Large holes.....	164
Small and medium size holes.....	164
Leather goods, care of.....	104
Life line and telephone combination cable.....	24
Lights, diving.....	61
Lights, diving and underwater illumination.....	49
Lines.....	64
Lines, mooring and diving.....	130
Location of diver, conditions indicating.....	157
Low pressure accumulators.....	140
Lubrication, general.....	144
Manifold, oxygen-helium diving.....	228
Manifolds, divers' air.....	65
Mechanical injuries.....	197
Metal parts, care of.....	104
Miller-Dunn shallow water diving outfit.....	97
Mixing oxygen and helium.....	214
Moorings and diving lines.....	130

	Page
Morse shallow water diving outfit.....	100
Motor launch dives, decompression in diving.....	175
Motor launch, manning and equipping of.....	133
Motor launches, use of air pumps in.....	132
Motor launches, use of compressed air in.....	132
Motor launches, use of gasoline driven air compressor.....	159
Movement on the bottom.....	157
Nature of work being performed, conditions indicating.....	18
Navy standard diving gear, description of.....	15
Navy standard diving outfits.....	125
Nitrogen.....	200
Nitrogen, helium a substitute for.....	246
Nozzles and lances, washing.....	103
Ohio Rubber Co. shallow water diving outfit.....	254
Omaha, salvage of.....	25
Outfit and helmet chests.....	220
Outfit, diving, for using oxygen-helium.....	124
Oxygen.....	214
Oxygen and helium, mixing of.....	220
Oxygen-helium, diving outfit for using.....	222
Helmet for oxygen-helium mixtures.....	200
Oxygen-helium mixture, deeper diving by use of.....	200
Oxygen-helium mixtures:	200
Experimental diving unit result of work.....	200
Mental and physical reaction to breathing.....	201
Restrictions on use.....	201
Special helmet for.....	234
Oxygen-helium mixtures, diving procedure when using.....	235
Ascent.....	235
Communication.....	234
Dressing the diver.....	235
Procedure during descent and on bottom.....	213
Oxygen-helium surface decompression.....	201
Oxygen-helium table and compressed air tables, difference in.....	203
Oxygen, maximum and minimum concentration of.....	197
Oxygen poisoning.....	202
Oxygen, use of, in repeated decompression.....	10
Physical qualifications of divers.....	124
Physics of diving.....	112
Piston assembly.....	112
Piston leathers, fitting of.....	129
Planning and arranging diving.....	197
Poisoning, oxygen.....	242
Pontoons and pontoon gear.....	88
Precaution when using diving communication equipment.....	126
Pressure.....	126
Absolute.....	127
Atmospheric.....	127
Gage.....	127
Water.....	165
Propellers and valves, clearing of.....	113
Pump deficiency, conditions contributing to.....	113
Pump deficiency, remedial repairs.....	113

	Page
Pump, diving air.....	65
Pump gages, test and correction of errors.....	110
Pump piston leathers, box for.....	18
Pump pressure gages, air.....	32
Pumps, air, care of.....	109
Pumps, efficiency of.....	111
Pumps, volumetric capacity of.....	111
Pump valves, leaky.....	113
Qualifications of divers, physical.....	10
Recompression chamber.....	238
Reexamination prior to diving.....	13
Repairs to hulls.....	134
Requisition, care and survey of diving gear.....	104
Requisitions for diving gear.....	120
Rubber goods, care of.....	104
<i>S-4</i> , salvage of.....	251
<i>S-51</i> , salvage of.....	250
Safety valve, helmet, care of.....	109
Salvage, and salvage vessels and special gear.....	237
Salvage equipment.....	238
Salvage of—	
<i>Omaha</i> .....	254
<i>S-4</i> .....	251
<i>S-51</i> .....	250
<i>Squalus</i> .....	251
Salvages, notable.....	249
Salvage squadron, composition of.....	238
Salvage, types.....	237
School, diving.....	2
Searching for lost articles.....	161
Shallow water diving.....	177, 179
Shallow water diving apparatus.....	96
Miller-Dunn type.....	96
Morse type.....	96
Ohio Rubber Co. type.....	96
Shallow water diving outfit.....	15
Care of.....	119
Shallow water masks.....	180
Shoes, diving.....	74
Signals.....	154
Signals, foul.....	155
Signals, special.....	155
Spare parts, box for.....	23
Special equipment, care of.....	120
Special gear.....	94
Special gear, salvage and salvage vessels.....	237
Squeeze.....	198
<i>Squalus</i> , salvage of.....	251
Stage, decompression.....	168
Regular.....	168
Surface.....	168
Tables.....	169
Stages, decompression.....	77

	Page
Standard diving outfits, navy.....	15
Stool, diver's dressing.....	78
Storage of diving gear.....	104
Storage of diving gear.....	238
Submarine rescue vessels.....	144
Submarine rescue vessel's diving air plant.....	213
Surface, decompression, oxygen-helium.....	119
Survey of diving gear.....	78
Tanks, testing.....	24
Telephone and life line combination cable.....	117
Care of.....	78
Telephones, diving.....	84
Amplifier type.....	82
Batteryless type.....	115
Care of.....	82
Dry cell type.....	128
Temperature of diving air.....	119
Tenders' transmitter and receiver, care of.....	154
Tending the diver.....	131
Tideway, diving in.....	172
Timekeeper.....	18
Tool bag, diver's.....	166
Tools, sending down.....	244
Tools, underwater velocity power.....	138
Torpedo air flasks.....	1
Training of navy divers.....	89
Trousers, overall.....	242
Underwater cutting and welding outfits.....	49
Underwater illumination and diving lights.....	244
Underwater velocity power tools.....	233
Underwear, electrically heated.....	244
Velocity power tools, underwater.....	137
Ventilation.....	111
Volumetric capacity of air pumps.....	246
Washing nozzles and lances.....	126
Water.....	127
Water pressure.....	18
Weighted belt.....	106
Weighted diving belts, care of.....	89
Weights.....	242
Welding and cutting outfits, underwater.....	105
Woodwork, care of.....	94
Woolens.....	105
Care of.....	162
Working about moorings.....	161
Working around corners.....	160
Working on muddy bottom.....	160
Working on rocky bottom.....	163
Working on ship's bottom.....	158
Working on the bottom.....	166
Working under water, rules.....	166

NJM 2019.012.048

