

NAVSHIPS 0905-071-4010
Trieste II Ship Information Book

In the collection of the
U.S. Naval Undersea Museum

NUM.2019.013.022



NAVSHIPS 0905-071-4010

TRIESTE II
SHIP INFORMATION
BOOK

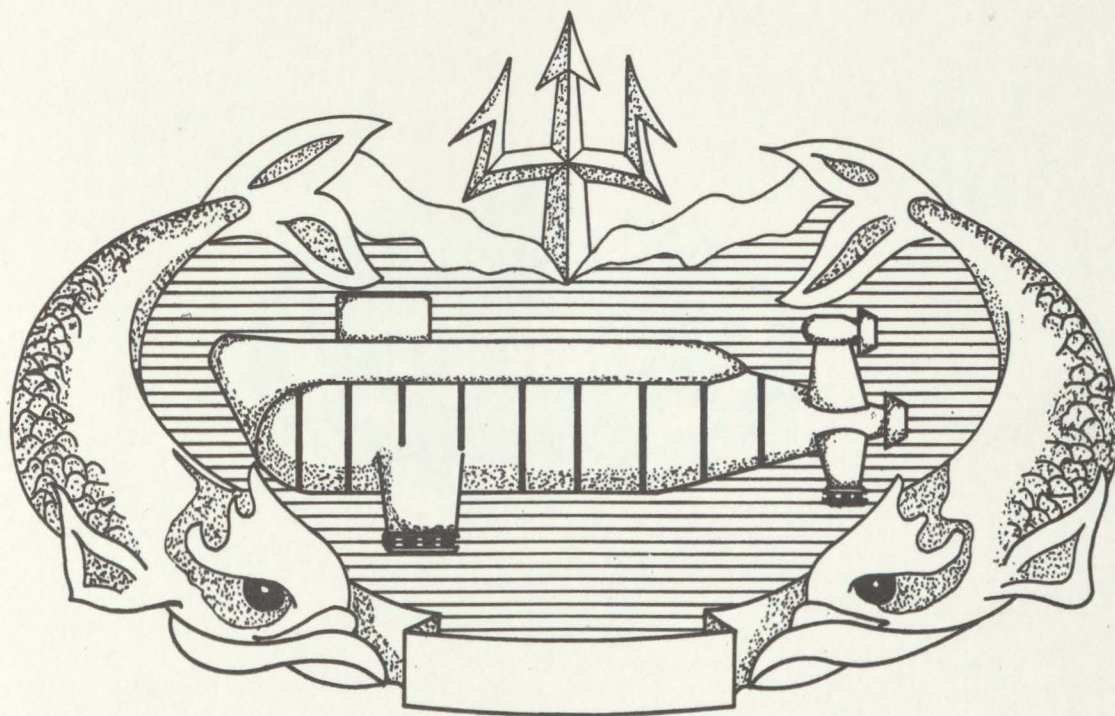

MARE ISLAND NAVAL SHIPYARD
VALLEJO, CALIFORNIA

NUWESNUMLIB

00105853



TRieste II

SHIP INFORMATION BOOK

CHANGE 1

NOVEMBER 1975

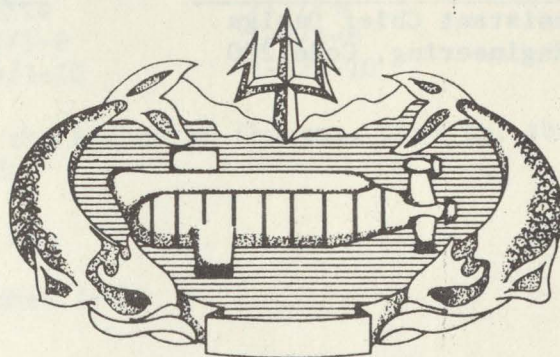

MARE ISLAND NAVAL SHIPYARD
VALLEJO, CALIFORNIA

PROPERTY OF THE
NAVAL UNDERSEA MUSEUM LIBRARY
KEYPORT, WA 98345

25 FEBRUARY 1975

TRIESTE II
SHIP INFORMATION BOOK
APPROVAL PAGE

SIGNATURE:

P. A. Green

DATE:

3/19/75

P. A. GREEN - Assistant Chief Design
Engineer, Ocean Engineering, Code 280

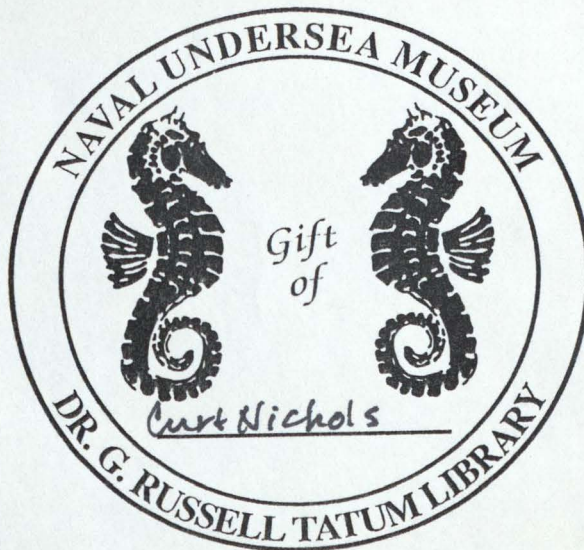

INSTRUCTION SHEET

Change 1

Change 1 to TRIESTE II (DSV-1) Ship Information Book
NAVSHIPS 0905-071-4010

General Instructions:

1. This change revises the manual to include information not available at time of printing.
2. Insert this Instruction Sheet in the manual immediately after the front cover preceding the Title Page.

Specific Instructions:

1. Remove the following pages and insert the corrected Change 1 pages:

<u>REMOVE</u>	<u>INSERT</u>	
Title/Approval Page	Title/Approval Page	Change 1
iii/iv	iii/iv	Change 1
1-7/1-8	1-7/1-8	Change 1
1-9/1-10	1-9/1-10	Change 1

2. Indicate on the Record of Changes, page iv, that this change has been incorporated.

DATED: 12 November 1975

TRIESTE II
SHIP INFORMATION BOOK

Distribution List

PMS-395A3		1
NAVSEA 924		1
NAVSEC		1
COMSUBPAC		1
CSDG-1		1
DSV-1		6
WEC VJO.		3
MINS		8
Code 202.1	(2)	
Code 213	(1)	
Code 280.0 ³	(1)	
Code 280.1	(1)	
Code 280.2	(1)	
Code 280.3	(1)	
Code 280.4	(1)	
	TOTAL	<u>22</u>

LIST OF EFFECTIVE PAGES

The total number of pages in the TRIESTE II (DSV-1) Ship Information Book, NAVSHIPS 0905-071-4010 is 345 consisting of the following:

<u>PAGE NUMBER</u>	<u>CHANGE NUMBER</u>
Title Sheet	Change 1
ii	Original
iii	Change 1
iv through xiv	Original
1-1	Original
1-1 through 1-7	Original
1-8 through 1-10	Change 1
1-11 through 1-34	Original
2-1	Original
2-1 through 2-40	Original
3-1	Original
3-1 through 3-68	Original
4-1	Original
4-1 through 4-106	Original
5-1	Original
5-1 through 5-12	Original
6-1	Original
6-1 through 6-16	Original
7-1	Original
7-1 through 7-30	Original
Glossary 1-1 through Glossary 1-6	Original
Glossary 2-1 through Glossary 2-12	Original

RECORD OF CHANGES

CHANGE NUMBER	DATE	TITLE & BRIEF DESCRIPTION	ENTERED BY

TRIESTE II
SHIP INFORMATION BOOK

TABLE OF CONTENTS

Chapter		Page
	LIST OF ILLUSTRATIONS	xii
	LIST OF TABLES	xiv
1	GENERAL INFORMATION	1-i
	1-1. Introduction	1-1
	1-2. General	1-1
	1-4. Purpose	1-1
	1-6. Scope	1-1
	1-8. Maintenance	1-2
	1-9. References	1-2
	1-10. Vehicle Description	1-2
	1-11. General	1-2
	1-12. Characteristics	1-2
	1-23. Vehicle Operation	1-11
	1-28. Historical Summary	1-11
	1-35. Mission Profile	1-13
	1-36. General	1-13
	1-38. Prepermission Planning	1-13
	1-39. Equipment Selection and Preparations	1-14
	1-44. Provisioning	1-15
	1-46. Transit	1-15
	1-50. Preundocking	1-16
	1-53. Undocking and Pre-dive	1-16
	1-56. Dive	1-17
	1-79. Work Task	1-19
	1-85. Ascent	1-20
	1-89. Surface Operations and Pre-Docking	1-20
	1-94. Docking	1-21
	1-95. Return Transit	1-21
2	PIPING SYSTEM	2-i
	2-1. Introduction	2-1
	2-3. Float Compensation System	2-1
	2-4. General Description	2-1
	2-5. AVGAS Tanks - Normal Compensation System	2-1
	2-6. AVGAS Tanks - Emergency Compensation System	2-1
	2-7. Maneuvering Tanks	2-1
	2-8. Compensating Valve	2-2
	2-9. AVGAS Compensating Trunk and Valve Cover	2-2

TABLE OF CONTENTS (Continued)

Chapter		Page
2	2-10. Maneuvering Valve	2-2
	2-11. AVGAS Filling and Pumping System	2-3
	2-12. General Description	2-3
	2-13. Preparation for Filling and Pumping	2-3
	2-14. AVGAS Filling and Pumping	2-3
	2-16. Inerting the Float	2-4
	2-17. Degassing the vehicle	2-4
	2-20. Materials	2-4
	2-21. AVGAS Tank Vent and Drain System	2-5
	2-22. General Description	2-5
	2-23. AVGAS Tank Vent System	2-5
	2-27. AVGAS Tank Drain System	2-5
	2-28. Low Pressure Venting	2-8
	2-29. Materials	2-9
	2-30. MBT, ECT & Access Trunk Blow and Vent System	2-9
	2-31. General	2-9
	2-32. Blow Down System	2-9
	2-33. Ballast Tank Piping	2-9
	2-34. Access Trunk Piping	2-9
	2-36. Electrical Compensation Tank Piping	2-9
	2-37. Ballast Tank Venting	2-10
	2-38. Access Trunk Venting	2-10
	2-39. Electrical Compensation Tank Venting	2-10
	2-40. Access Trunk HP Blow System	2-10
	2-41. General Description	2-10
	2-42. Blow Down Procedures and Components	2-10
	2-50. MBT, ECT & Access Trunk Flood and Drain System	2-11
	2-51. General Description	2-11
	2-52. Forward and Aft MBT Flood and Drain System	2-11
	2-54. Electrical Compensation Tank (ECT) Static Pressure System	2-12
	2-55. ECT Flood and Drain System	2-12
	2-57. Access Trunk Flood and Drain System	2-12
	2-61. Nitrogen Inerting System	2-13
	2-62. General Description	2-13
	2-63. Portable Nitrogen Inerting System	2-13
	2-66. Permanent Nitrogen Inerting System	2-13
	2-68. Electrical Equipment Compensation System	2-14
	2-69. General Description	2-14
	2-70. System Arrangement	2-14
	2-71. Ship's Service Compensator System	2-15
	2-74. Battery Compensation System	2-15
	2-76. Compensation System Identification and Description	2-15
	2-77. Fluids Used for Electrical Compensation	2-16
	2-84. Appendage Compensation System	2-17
	2-90. Shock Mitigation System	2-18

TABLE OF CONTENTS (Continued)

Chapter		Page
3	ELECTRICAL SYSTEM	3-i
3-1.	Introduction	3-1
3-3.	General System Description	3-1
3-6.	Power Distribution System	3-1
3-7.	General	3-1
3-8.	24-VDC External Power Distribution System	3-2
3-23.	120-VDC Power Distribution System	3-5
3-38.	24-VDC Sphere Power Distribution System	3-8
3-47.	AC Power Distribution System	3-10
3-52.	24-VDC Essential Battery Power System	3-11
3-54.	Computer Power Supply	3-12
3-55.	CTFM Sonar Power Supply	3-12
3-56.	Internal 12-VDC Power System	3-12
3-57.	Battery Monitoring System	3-12
3-61.	Propulsion System	3-13
3-62.	General	3-13
3-63.	Thruster Motors	3-13
3-65.	Motor Controllers	3-14
3-67.	Propulsion Control Panel (Unit 700A10)	3-14
3-68.	General	3-14
3-77.	Lighting System	3-16
3-78.	General	3-16
3-79.	Lighting Control Panel (Unit 700A15)	3-17
3-82.	TV Lights (Units 926, 927, 929, 933, 934, 936)	3-17
3-84.	Searchlights (Units 705A1, 705A2, 930, 937)	3-18
3-86.	Silo Lights (Units 774, 775, 776, 777)	3-18
3-88.	Floodlights (Units 737 through 740)	3-18
3-89.	Recognition Lights	3-19
3-90.	Navigation Lights	3-19
3-92.	Interior Lights (Sphere)	3-19
3-93.	Lighting Control Panel (Unit 700A15)	3-19
3-96.	Multivapor Ballasts (Units 925, 928, 932, 934)	3-20
3-98.	Search Pre-Regulator (Unit 704)	3-20
3-99.	Lighting Contactor Bottle No. 1 (Unit 713)	3-20
3-100.	Lighting Contactor Bottle No. 2 (Unit 714)	3-20
3-101.	Optical Systems	3-20
3-104.	Safety Systems	3-24
3-105.	General	3-24
3-106.	Master Alarm System	3-24
3-108.	Antechamber Blow System	3-26
3-109.	General	3-26
3-112.	Buoyancy Control System	3-26
3-113.	General	3-26
3-114.	Ballast Control Panel (Unit 700A22)	3-27
3-121.	Trail Ball Winch and Cable Tension Sensor System	3-28
3-122.	Emergency Release Mechanisms	3-28

TABLE OF CONTENTS (Continued)

Chapter		Page
4	ELECTRONICS SYSTEM	4-i
	4-1. Introduction	4-1
	4-3. General Description	4-1
	4-9. Navigation Computer System	4-2
	4-10. System Description	4-2
	4-14. Computer	4-3
	4-23. Computer Depth Transducer System	4-4
	4-24. General	4-4
	4-25. System Operation	4-5
	4-26. Doppler Sonar System	4-5
	4-27. General	4-5
	4-28. Transducer Unit Assembly (Unit 785)	4-5
	4-29. Electronics Panel (Unit 700A24)	4-5
	4-30. Display Panel (Unit 700A08)	4-6
	4-31. Transponder Interrogator Sonar System	4-6
	4-32. General	4-6
	4-34. Transducers	4-6
	4-35. TIS Electronics Bottle (Unit 768)	4-6
	4-36. TIS Processor (Unit 700A32)	4-7
	4-37. TIS Display Panel	4-7
	4-38. TIS Operating Modes	4-7
	4-44. Gyrocompass and Heading Display	4-8
	4-45. General	4-8
	4-46. Gyrocompass Control Panel	4-8
	4-54. Gyrocompass Repeater and Indicator Panel	4-11
	4-58. Sonar System	4-11
	4-59. General	4-11
	4-60. CTFM Sonar System	4-11
	4-70. Fathometer	4-14
	4-71. General	4-14
	4-74. Depth Indicator System	4-14
	4-75. General	4-14
	4-76. Depth Indicator Panel	4-14
	4-77. Beacon Release System	4-15
	4-78. General	4-15
	4-79. Beacon Control Panel	4-15
	4-81. Junction Block No. 3	4-15
	4-82. Beacon Release Relay Bottle	4-16
	4-83. Transponder Release Assembly	4-16
	4-88. Sound Velocimeter System	4-17
	4-89. General	4-17
	4-90. Sound Velocimeter	4-17
	4-95. Sound Velocimeter Display	4-18
	4-99. Communication System	4-18
	4-100. General	4-18
	4-101. Communications Panel (Unit 700A37)	4-18

TABLE OF CONTENTS (Continued)

Chapter		Page
4	4-102. Underwater Telephone	4-18
	4-106. Sound-Powered Telephones	4-19
	4-107. VHF Radio	4-19
	4-108. Tape Recorder	4-19
	4-109. Emergency/Tracking Pinger (Unit 753)	4-19
	4-110. Vehicle Transponder (Unit 754)	4-19
	4-111. Camera Systems	4-20
	4-112. General	4-20
	4-113. TV System	4-20
	4-126. TV Control Panel (Unit 700A101)	4-22
	4-130. Pan & Tilt Control Panel (Unit 700A66)	4-23
	4-131. General	4-23
	4-132. Selection and Control	4-23
	4-133. Pan and Tilt Position Indication	4-23
	4-135. TV Monitors (Units 700A04, 700A09)	4-24
	4-138. Video Tape Recorder (Unit 700A103)	4-24
	4-141. 70mm System	4-24
	4-142. General	4-24
	4-143. 70mm Camera (Units 733, 734, 715)	4-24
	4-145. Electronic Strobes (Units 735, 736, 750)	4-25
	4-146. General	4-25
	4-147. Power and Control	4-25
	4-149. Lighting Control Panel (Unit 700A15)	4-25
	4-150. General	4-25
	4-151. Control Functions	4-25
	4-152. Control Circuitry	4-26
	4-153. Controls and Indicators	4-26
	4-154. A Port/STBD Still Camera Single Stereo	4-26
	4-155. Power	4-26
	4-156. Multiplex System	4-28
	4-157. General	4-28
	4-158. Circuit Components	4-28
	4-159. Circuit Description	4-28
	4-161. Internal Multiplex (Unit 700A11)	4-29
	4-164. External Multiplex (Units 900 through 903)	4-29
5	LIFE SUPPORT SYSTEM	5-i
	5-1. Introduction	5-1
	5-3. General Description	5-1
	5-5. Thermoelectric (T/E) Unit	5-1
	5-7. Thermoelectric Core	5-1
	5-9. Water System	5-2
	5-11. Environmental Control	5-3
	5-13. Oxygen (O ₂) System	5-3
	5-15. O ₂ System Components	5-3
	5-17. CO ₂ Removal Unit	5-4

TABLE OF CONTENTS (Continued)

Chapter		Page
5	5-21. Atmospheric Monitoring Equipment	5-4
	5-23. Oxygen Monitoring	5-4
	5-24. CO ₂ Monitoring	5-5
	5-25. Cabin Temperature	5-5
	5-26. Cabin Humidity	5-5
	5-27. Cabin Pressure	5-5
	5-28. Waste Disposal System	5-5
	5-30. Emergency Breathing System	5-5
	5-31. General	5-5
	5-32. System Components	5-5
	5-33. System Operation	5-6
	5-36. Emergency Breathing System (EBS) Communications	5-6
6	HULL AND MACHINERY	6-1
	6-1. Introduction	6-1
	6-3. Sphere	6-1
	6-4. General	6-1
	6-5. Hemispherical Unit	6-1
	6-6. Hatch	6-1
	6-7. Windows	6-2
	6-9. Penetrators	6-2
	6-10. Sphere Installation	6-2
	6-11. Hull Attachment	6-2
	6-13. Bumpers	6-3
	6-14. Sphere Orientation	6-3
	6-15. Access Trunk Seal	6-3
	6-16. Float Construction	6-3
	6-18. Superstructure	6-3
	6-19. General	6-3
	6-21. Walking Area	6-4
	6-22. Sides	6-4
	6-23. Installation and Preservation	6-4
	6-24. Fairwater	6-4
	6-25. General	6-4
	6-27. Fairwater Equipment	6-4
	6-28. Reach Rods and Operating Gear	6-4
	6-29. General	6-4
	6-30. Electrical Compensation Tank Flood and Drain Valve	6-4
	6-31. Main Ballast Tank Vent Valves	6-5
	6-32. Access Trunk Flood Valve	6-5
	6-33. Foundations	6-5
	6-34. General	6-5
	6-35. Construction	6-5
	6-37. Tripping Levers	6-5
	6-38. General	6-5
	6-39. Operation and Control	6-6

TABLE OF CONTENTS (Continued)

Chapter		Page
6	6-40. Weak Link and Guillotine Cable Separation	6-6
	6-43. Battery Boxes	6-6
	6-44. General	6-6
	6-45. Construction	6-7
	6-46. Handling	6-7
	6-47. Stabilizers	6-7
	6-48. General	6-7
	6-50. Forward Landing Skegs	6-7
	6-51. Propulsion	6-7
	6-52. General	6-7
	6-53. Functions	6-8
	6-54. Nozzles and Fairing	6-8
	6-56. Protective Equipment for Towing	6-8
	6-57. Bow Winch	6-8
	6-58. General	6-8
	6-59. Power and Braking	6-8
	6-60. Holding Mechanism	6-9
	6-61. Trail Ball Winch	6-9
	6-62. General	6-9
	6-63. Control Panel	6-9
	6-66. Winch Capabilities	6-10
	6-67. Power and Drive Train	6-10
	6-69. Footage Counter	6-10
	6-70. Jettisoning Provisions	6-10
	6-71. Compensation	6-10
	6-72. Manipulator Arm	6-10
	6-73. General	6-10
	6-74. System Components	6-11
	6-75. Power and Control	6-11
	6-79. Articulated and Fixed Platforms	6-11
	6-83. Fire Fighting Equipment	6-12
7	SUPPORT SHIP INTERFACE	7-i
	7-1. Introduction	7-1
	7-3. USS Point Loma Ship Characteristics	7-1
	7-5. General Support Ship Capabilities	7-1
	7-7. Services and Interfaces	7-2
	7-8. General	7-2
	7-12. Towing System	7-3
	7-16. Undocking, Docking and Tie Down	7-3
	7-24. AVGAS System	7-5
	7-30. Nitrogen System	7-5
	7-31. High-Pressure Air System	7-6
	7-34. Low-Pressure Air System	7-6
	7-38. Fire Main System	7-6
	7-39. Battery Charging Facilities	7-6
GLOSSARY 1	List of Abbreviations and Acronyms	GL1-1
GLOSSARY 2	References	GL2-1

LIST OF ILLUSTRATIONS

Number		Page
1-1.	Trieste II (DSV-1) Servicing a Deep Wellhead	1-23
1-2.	Trieste II (DSV-1) Equipment Configuration	1-25
1-3.	Personnel Sphere	1-27
1-4.	Sail Equipment Arrangement	1-29
1-5.	Principles of Bathyscaph Operation - Balloon Analogy . . .	1-31
1-6.	Sphere Control and Instrument Layout	1-33
2-1.	Float Compensation System.	2-21
2-2.	AVGAS Filling and Pumping System	2-23
2-3.	AVGAS Tank Vent and Drain System	2-25
2-4.	LP Blow and Vent System and MBT Vent and Drain System. . .	2-27
2-5.	HP Air System.	2-29
2-6.	Nitrogen Inerting System	2-31
2-7.	Electrical Equipment Compensation System (Typical)	2-33
2-8.	Battery Compensation System.	2-35
2-9.	Appendage Compensation System.	2-37
2-10.	Landing Gear Shock Mitigation System	2-39
3-1.	24-VDC External Power Distribution System.	3-29
3-2.	12-VDC Power Distribution System	3-31
3-3.	24-VDC Sphere Power Distribution System.	3-33
3-4.	Master Power Panel	3-35
3-5.	Port Power Panel	3-37
3-6.	Starboard Power Panel.	3-39
3-7.	External AC Power Distribution System.	3-41
3-8.	AC Power Panel	3-43
3-9.	Internal AC Power Distribution System.	3-45
3-10.	Propulsion System Power and Control System	3-47
3-11.	Propulsion Control Panel	3-49
3-12.	Lighting System Block Diagram.	3-51
3-13.	Lighting Control Panel	3-53
3-14.	Master Alarm System.	3-55
3-15.	Master Alarm Panel	3-57
3-16.	Antechamber Blow System.	3-59
3-17.	Buoyancy Control System.	3-61
3-18.	Ballast Control Panel.	3-63
3-19.	Trail Ball Winch and Cable Tension System.	3-65
3-20.	Emergency Buoyancy Release System.	3-67
4-1.	Navigation Computer System, Sheet 1 of 2	4-33
4-1.	Navigation Computer System, Sheet 2 of 2	4-35
4-2.	Computer Control Panel (Unit 700A11)	4-37
4-3.	Analog Plotter (Unit 700A16)	4-39
4-4.	Computer Depth Transducer System	4-41
4-5.	Pressure Transducer Panel - Unit 700A25.	4-43
4-6.	Doppler Sonar System	4-45
4-7.	Doppler Sonar Display.	4-47
4-8.	Navigational Transponder Interrogator Sonar (TIS) System .	4-49
4-9.	Transponder Interrogator Processor and Display Units . . .	4-51

LIST OF ILLUSTRATIONS (Continued)

Number		Page
4-10.	Gyroscope and Heading Display System	4-53
4-11.	Gyrocompass Control Panel	4-55
4-12.	Gyrocompass Repeater and Indicator Panel	4-57
4-13.	CTFM Sonar System.	4-59
4-14.	CTFM Sonar Display (Unit 700A17)	4-61
4-15.	CTFM Analyzer (Unit 700A18).	4-63
4-16.	Fathometer (Depth Sounder) System.	4-65
4-17.	Fathometer Display (Unit 700A21)	4-67
4-18.	Depth Indicator System	4-69
4-19.	Depth Indicator Display.	4-71
4-20.	Beacon Release System.	4-73
4-21.	Beacon Control Panel	4-75
4-22.	Sound Velocimeter System	4-77
4-23.	Sound Velocimeter Display.	4-79
4-24.	Communications System.	4-81
4-25.	Communications Panel (Unit 700A37)	4-83
4-26.	TV System.	4-85
4-27.	TV Control Panel	4-87
4-28.	Pan & Tilt Control Panel	4-89
4-29.	Single TV Monitor.	4-91
4-30.	Dual TV Monitor (Unit 700A04).	4-93
4-31.	70mm Camera and Strobe System.	4-95
4-32.	70mm Camera Control and Lighting Panel	4-97
4-33.	Internal Multiplex Unit.	4-99
4-34.	External Multiplex Bottle (Port)	4-101
4-35.	Lighting Control Panel (Unit 700A15) and Multiplex Power Control Switches	4-103
4-36.	Multiplex 67 Bit Serial Code	4-105
5-1.	Life Support System with Thermoelectric Unit	5-7
5-2.	Main O ₂ System	5-9
5-3.	Emergency O ₂ System.	5-11
6-1.	Electromagnetic Tripping Lever	6-13
6-2.	Manipulator Hydraulic Block System	6-15
7-1.	Support Ship Services and Interface.	7-11
7-2.	Docking Well and Beach Area.	7-13
7-3.	Vehicle Handling Lines	7-15
7-4.	Undocking Arrangement.	7-17
7-5.	In-Transit Lashing Arrangements Plan View.	7-19
7-6.	In-Transit Lashing Arrangements Elevation.	7-21
7-7.	Transit Configuration.	7-23
7-8.	Nitrogen System Interface.	7-25
7-9.	High-Pressure Air Service Outlet	7-27
7-10.	Battery Charging Facility and Cabling.	7-29

LIST OF TABLES

Number		Page
1-1	Vehicle Dimensions	1-5
1-2	Tank Capacities	1-8
1-3	Displacement and Stability Data	1-9
1-4	Design Summary	1-13
1-5	Personnel Qualified as Hydronauts	1-14
2-1	AVGAS Tank Vent Valve Locations	2-6
2-2	AVGAS Tank Drain Valve Locations	2-7
2-3	Nitrogen Inerting System - Tank Zone Identification	2-14
2-4	Rubber Compensators Located in the ECT	2-16
2-5	Battery Compensators Located in the MBT	2-16
3-1	Lighting System Components and Locations	3-22
3-2	Systems Monitored by Master Alarm System	3-25
4-1	Gyrocompass Control Panel - Controls and Indicators	4-9
4-2	70mm Camera Control Functions	4-27
4-3	Multiplex Data Bit Functions	4-30

GENERAL

CHAPTER 1
GENERAL INFORMATION

Number		Page
1-1.	Introduction	1-1
1-4.	Purpose	1-1
1-6.	Scope	1-1
1-10.	Vehicle Description	1-2
1-23.	Vehicle Operation	1-11
1-28.	Historical Summary	1-11
1-35.	Mission Profile	1-13

CHAPTER 1

GENERAL INFORMATION

1-1. INTRODUCTION.

1-2. GENERAL. This Ship Information Book (SIB) describes the hull systems and equipment that comprise the bathyscaph Trieste II (DSV-1), the U.S. Navy's deepest diving submersible. The technical information provided herein includes all modifications made to the DSV-1 bathyscaph (vehicle) during the overhaul period completed at Mare Island Naval Shipyard in 1975.

1-3. The Ship alterations (SHIPALTS) incidental to the regular 1974 - 1975 overhaul included: propulsion and control modifications to improve maneuverability of the vehicle; sensor and lighting changes; piping modifications to the oxygen and nitrogen systems; sphere equipment modifications; the addition of a Deep Ocean Transponder (DOT) launch capability; and improved communications systems; EMI shielding; and general rearrangements.

1-4. PURPOSE.

1-5. The purpose of this SIB is to provide a detailed description of the equipment suite inboard and outboard of the vehicle (and within the sphere) and to define the functional relationships between the equipment and a particular mission task. The role of the support ship in the overall Trieste II operational dive is also described. The material presented is primarily intended to serve as a training aid for new DSV-1 personnel and also to assist those commands engaged in mission planning. The sophisticated electronic gear and gas systems aboard the vehicle, combined with the prudent staffing constraints, necessitate thorough cross-training of all technical personnel associated with Trieste II operations. This SIB is intended to assist in the on-going training task by providing a basic guide to overall operations and systems.

1-6. SCOPE.

1-7. The technical descriptions provided in this SIB are presented at the block diagram level and are related to the specific operational task most commonly identified with the unit or system. The material is presented in seven chapters: Chapter 1 provides a general description of the overall vehicle and its equipment suite, including a hypothetical mission profile that is intended to establish a baseline for the introduction of equipments in later chapters; Chapter 2 describes the piping systems of the vehicle along with their operational function; Chapter 3 describes the electrical systems and power sources for the vehicle; Chapter 4 provides an extensive coverage of the systems and equipment comprising the electronic suite; Chapter 5 covers the life-support systems and their backup counterparts; Chapter 6 describes the hull and machinery of the vehicle; and Chapter 7 provides information on the support ship interface with the vehicle.

1-8. MAINTENANCE. Maintenance information is not provided in this SIB. Where critical preventative measures are involved, these are presented in "note" or "cautionary" form to serve as a redundant training tool rather than an operational procedure. The Trieste II crew is trained in the U.S. Navy Preventive Maintenance System (PMS) and those procedures are applied as required. No attempt is made to provide "hands-on" operational information in this SIB. Operation is only discussed to the level necessary to familiarize a new crewman with system function and interrelationships. Where hazards to human life are involved, these are called out specifically and marked in accordance with MIL-M-15071G (Navy) and MIL-M-38784.

1-9. REFERENCES. A bibliography of references is presented following the glossary of terms. These references consist of drawings, publications and procedures directly related to the vehicle and its equipment. They are provided as a source of additional technical information for the reader. A direct reference system was purposely avoided, so as to eliminate the distraction factor inherent with multiple reference designations in the text. The references are presented under chapter headings and listed generically, in the general order of the subject's appearance in the text. Arbitrary numbers have been assigned to the references as a general locating aid.

NOTE

Where specific technical data or design parameters are required on the systems described in this SIB, the reader is advised to consult the referenced documents.

1-10. VEHICLE DESCRIPTION.

1-11. GENERAL. The bathyscaph, a word derived from the Greek words bathos (deep) and scaphos (ship), may be simply compared to an underwater dirigible. It has the same two major assemblies as the dirigible; a buoyancy chamber (float) and a cabin (sphere). In the same manner as the dirigible bag is filled with lighter-than-air gas, the float of the Trieste II (vehicle) is filled with lighter-than-water liquid (aviation gasoline or AVGAS). Using the same dirigible analogy, the vehicle is designed to go up and down by weight control. This control is provided by discharging shot ballast (BB size iron shot), or by valving off AVGAS to make the vehicle lighter or heavier than the surrounding liquid (seawater). The float contains 66,000 gallons of AVGAS for positive buoyancy. Figure 1-1 shows an artists concept of the vehicle at work on the bottom, using the articulated "manipulator arm" to open an access hatch on the "hypothetical" wellhead.

1-12. CHARACTERISTICS. The Trieste II is a self-propelled, gasoline filled bathyscaph. It consists of a float, a personnel sphere and necessary appendages (landing gear and stabilizers) to provide bottom stability and a propulsion capability. Figure 1-2 shows the outboard profile and equipment placement on the vehicle and Figure 1-3 provides a cutaway view of the personnel sphere which is recessed into the lower forward portion of the float.

1-13. The vehicle has an overall length of 78 feet, 6 5/8 inches (excluding the bow frame which allows the attachment of various recovery devices) and a height of 26 feet 11 inches. The vehicle displaces 276.15 long tons (618,576 pounds) surfaced and 304.78 long tons (682,619 pounds) submerged.

1-14. Float. The float hull is essentially a hydrodynamically shaped container housing the two ballast tanks and the AVGAS tanks which provide buoyancy for the sphere and other nonbuoyant items (including the float). The float also serves as a vehicle for supporting the batteries, propulsion motors, auxiliaries, sensors, devices and other equipment (Figure 1-2).

1-15. The torpedo like shape of the float is a compromise between minimum resistance (both surfaced and submerged) and hull weight-to-volume ratio. The hydrodynamic shape, with an L/D ratio of 4.86, is a streamlined body of revolution with low resistance, good propulsive efficiency and low hull weight-per-unit-volume enclosed. The main body of the float is 15 feet 3 inches-ID cylinder, with a hemispherical bow and conical stern, which is attached to the cylindrical body by a toriconical section. All hull plating is 10 gage (.134 inch thick) HTS except for 3/16 inches HTS plate in way of stern stabilizers.

1-16. The upper bow structure forms part of the forward ballast tank. The faired shape of the float makes it hydrodynamically suitable for surface towing.

1-17. Superstructure. The superstructure extends from the aft end of the upper bow structure to about Frame (FR) 25, where it slopes down to the conical section of the float. The superstructure forms a fairing to cover the topside piping, wiring and equipment and provides a walking platform for surface operations.

1-18. Sphere Access Trunk Fairwater. The sphere access trunk (Figure 1-4) terminates about three feet above the top of the cylindrical portion of the float at two feet aft of Frame 9. A streamlined fairwater is positioned around the top of the access trunk providing wave protection for personnel entering or leaving the sphere and a location for topside sensor foundations, AVGAS filling, battery charging, and blow connections.

1-19. Tanks and Recesses. There are two longitudinal bulkheads 2 feet 6 inches port and starboard of centerline that run from the bow to a transverse bulkhead at Frame 32. The space inboard and outboard of these bulkheads is subdivided into tanks by transverse bulkheads. A recess is located forward in the float for the upper half of the personnel sphere, and aft for the trail rope winch. Two shot silos (or tanks) are located forward, port and starboard, of the personnel sphere, and one aft on centerline.

1-20. Sphere. A spherical shape is used for the operator's compartment (Figure 1-3) because the inherent characteristics of a sphere make it the most efficient pressure resistant shape. The sphere also provides the maximum space enclosed by the least material. The sphere openings are kept to a minimum number and size because they affect its structural integrity by upsetting the uniform distribution of load over its total surface. The thickness of the sphere is increased in penetration areas to compensate for metal removed.

1-21. Definitions. The following definitions are provided to assist the reader in establishing reference points from which the measurements are made. Figure 1-2 shows the general locations of areas discussed in the "Vehicle Dimensions", Table 1-1; Tank Capacities, Table 1-2; and Displacement and Stability Data, Table 1-3.

1. Ton (long) - 2240 pounds.
2. Molded line (ML) is to the inside of hull plating.
3. Molded base line (MBL) is a horizontal construction line at the bottom inboard surface of shell plating.
4. Above base line (ABL). Below base line (BBL).
5. Centerline (CL) is a construction line or vertical plane to which all transverse dimensions are referred.
6. Main axis (MA) is the horizontal CL 7 feet 7 1/2-inches ABL.
7. Designers water line (DWL) is the designed water line in surface diving trim. (Referred to the base line, BL.)
8. Perpendiculars are vertical construction lines near the extremities of the ship to which FWD and AFT dimension are referred. The FWD perpendicular (FP) is at the intersection of the main axis and the continuation line of the inside of the dome plating. The after perpendicular (AP) is located at the 6-inch half breadth (HB) on the tail cone. The Midship Perpendicular is half-way between FP and AP.
9. The length between perpendiculars (LBP).
10. The length over all (LOA).
11. Aviation Gasoline (AVGAS).

Table 1-1. Vehicle Dimensions

PRINCIPAL DIMENSIONS	
<u>Lengths</u>	
LBP	74'-0"
LOA (Excluding bow frame)	78'-6 5/8"
Bow forward of FP	1'-7"
Bow frame forward of FP	9'-4"
CL motor nozzle aft of AP	2'-11 5/8"
<u>Breadths</u>	
Max hull beam	15'-3 1/4"
Max breadth (wing motors)	18'-9"
<u>Heights</u>	
Top of fairwater	21'-3"
Main deck amidships	17'-0 1/2"
Main deck fwd ball tank	17'-4"
Top of fairwater appendages (Mast Extended)	33'-7 1/2"
<u>Depth below base line</u>	
Sphere	4'-2"
Sphere guard	3'-8"
Manipulator (stowed)	3'-6"
Manipulator (extended)	7'-10"
Doppler sonar	0'-6"
Aft landing gear (extended)	3'-6"
Fwd landing gear (extended)	5'-8"

Table 1-1. Vehicle Dimensions (Continued)

PRINCIPAL DIMENSIONS	
<u>Distances (Aft of FP)</u>	
Sphere (CL)	16'-9"
Horizontal Velocity Sensor	24'-8"
Manipulator (CL)	4'-6"
Fwd shot silos	18'-1/2"
Aft shot silo	44'-4 1/2"
Stabilizers (CL)	66'-9 1/4"
<u>Frame Spacing</u>	
FP to FR 0	12"
FR 0 to FR 13	20"
FR 13 to FR A (1)	18 1/2"
FR A to FR D (3)	18"
FR 0 to FR 14 (1)	19 1/2"
FR 14 to FR 25	20"
FR 25 to FR 26	18"
FR 26 to FR 27	27 5/16"
FR 27 to FR 28	18 11/16"
FR 28 to FR 35	18 1/2"
FR 35 to FR 40	20"
FR 40 to AP	10 1/2"
<u>Main transverse bulkhead locations</u>	
Center tanks	Dist Aft of FP
5 3/8" Fwd FR 2	3'-10 5/8"
12" Aft FR 6	12'-0"
7 1/2 Fwd FR 14	29'-8 1/2"

Table 1-1. Vehicle Dimensions (Continued)

PRINCIPAL DIMENSIONS	
Main transverse bulkhead locations	Dist. Aft of FP
<u>Center Tanks</u>	
5/8" Aft FR 19	38'-8 5/8"
8" Aft FR 23	46'-0"
13" Aft FR 26	51'-3"
3 1/2" Fwd FR 29	55'-3"
Aft FR 32	60'-2"
<u>Wing Tanks</u>	
2" Aft FR 2	4'-6"
5" Fwd. FR 6	10'-7"
8" Aft FR 9	16"-8"
12 1/2" Aft FR 13	23'-8 1/2"
7 1/2" Fwd FR 14	29'-8 1/2"
5/8" Aft FR 19	28'-8 5/8"
7" Fwd FR 23	44'-9"
7 7/17" Aft FR 26	50'-9 7/16"
9" Fwd FR 31	57'-10 1/2"

Table 1-2. Tank Capacities

TANK NUMBER	GALLONS	TONS
Gasoline Tanks @ 5.8311	Pounds/Gal.	@ 25°C
1A and 1B	4676	12.17
2A and 2B	4630	12.05
3A and 3B	4736	12.31
4A and 4B	4776	12.43
5A and 5B	7164	18.65
6A and 6B	4800	12.50
7A and 7B	4808	12.52
8A and 8B	4284	11.15
9A and 9B	3468	9.03
1C	4059	10.57
2C	4975	12.95
3C	2600	6.77
5C	3023	7.87
6C	<u>2686</u>	<u>6.99</u>
Subtotal	60685 Gal.	157.96
Fwd maneuvering	344	0.90
Main maneuvering	<u>4990</u>	<u>12.99</u>
Total maneuvering	<u>5334 Gal.</u>	<u>13.89</u>
TOTAL	66019 Gal.	171.85

Table 1-2. Tank Capacities (Continued)

TANK NUMBER	GALLONS	TONS
<u>Sea Water Ballast @ 63.878 Gal.</u>		
Fwd ballast tank	488.2	13.92
Aft ballast tank	461.7	13.17
Access trunk	<u>79.5</u>	<u>2.27</u>
TOTAL	1029.4	29.36
Electrical Comp Tank @ 8.52 lbs/gal	627 Gal.	2.38

Table 1-3. Displacement and Stability Data

	TONS
<u>Light Ship - Condition A</u>	
Ship without ballast, Condition A-1	73.89
Lead ballast (corr for SW displ)	<u>0.89</u>
Ship in Condition A	74.78
Draft Fwd (FDM)	4.59 Ft.
Draft Aft (ADM)	4.91 Ft.
Trans metacenter ABL	7.41 Ft.
Vert CG ABL	6.29 Ft.
Trans metacenter (GM)	1.12 Ft.
<u>Normal Diving Trim (NDT) -</u> <u>Surface Cond. @ 25°C</u>	
Light Ship - Condition A	74.78
Personnel VL-01	0.21
SW in recesses VL-07	0.95
Oil in comps VL-09	2.95

Table 1-3. Displacement and Stability Data (Continued)

	TONS
Elect comp tank (SW) VL-10	2.37
Gasoline (incl man tks @ 5.881 lbs/gal) VL-20 & 27	171.85
Shot ballast (Fwd and Aft)	19.12
Residual water VL-28	<u>0.28</u>
Ship Normal Diving Trim (NDT)	272.53
Draft Fwd (FP)	<u>13'-3-3/8"</u>
Draft Aft (AP)	<u>12'-10-1/4"</u>
Trans metacenter	7.64 Ft.
Vert CG	7.23 Ft.
Trans metacenter height (GM)	0.41 Ft.
<u>Normal Shallow Submerged (NSH) -</u>	
Normal diving trim (NDT) - Surface condition	272.53
Main ballast water	<u>29.38</u>
Normal Shallow (NSH)-Submerged	301.91
Vert CB	7.77 Ft.
Vert CG	<u>7.38 Ft.</u>
Metacenter height	0.39 Ft.

1-22. Propulsion. The vehicle is propelled by three 6.5 hp DC electric motors. One motor is installed at the after end of the vehicle along the centerline and the other two are mounted on wing-type extensions at the stern. The two motors are mounted on a 15-degree angular offset to provide maneuvering capability in lieu of a rudder. A fourth motor is mounted on the bow with its thrust axis perpendicular to the centerline of the vehicle to assist in maneuvering. The motors are powered by a 120-VDC, 952-ampere-hour silver-zinc battery. A second 24-VDC, 5000-ampere-hour silver-zinc battery provides power for auxiliary loads. All motors, batteries and control circuitry housings are pressure compensated, using sea pressure and various compensating fluids.

1-23. VEHICLE OPERATION (Figure 1-5).

1-24. The float containing 66,000 gallons of AVGAS provides the lift for the bathyscaph. The end compartments of the float are floodable, and when filled with seawater, the vehicle has a slightly negative buoyancy. When the bathyscaph descends, the increasing pressure compresses the AVGAS. A compensating valve on the float allows seawater to enter the bottom of the float to maintain the pressure inside equal to that outside. When the vehicle ascends, the reverse conditions exists and the seawater is pushed out again.

1-25. Silver-zinc storage batteries provide the power to run the propulsion system, lights and the scientific and operational equipment.

1-26. Expendable ballast (BB size iron shot) is carried in large tubs (silos) and discharged as required to control buoyancy. Discharge of the ballast is controlled by an electromagnetic valve in the orifice of each silo. While the current is maintained, the shot remains frozen in the orifice; when the current is turned off, or the electrical system fails, the magnetic field ceases and the shot flows out. This method produces a "fail-safe" system for the vehicle.

1-27. The sphere (Figure 1-3) is a major pressure-resistant part of the vehicle. The sphere is designed for operating depth of 20,000 feet. The pressure inside the sphere is maintained at 1 atmosphere so that no effect of the sea pressure is experienced by the personnel at any depth. Operating controls (Figure 1-6) are located inside the sphere, as are all monitoring devices and instrumentation. The operators ride in the sphere occupying the small remaining space. The observation window is made of 6-inch thick plexiglass oriented forward and slightly downward which provides the hydronaut with a good view of the sea floor.

1-28. HISTORICAL SUMMARY.

1-29. The bathyscaph was conceived, designed, and constructed by Professor Auguste Piccard, a Swiss physicist and inventor who had made an earlier mark in scientific history as the inventor and pilot of the stratospheric balloon, FNRS.¹ On May 27, 1931 Piccard and an associate, Paul Kipfer ascended through the tropospheric upper limit of 7 1/2 miles and continued to a height of nearly 10 miles above the earth.² Professor Piccard followed his success as an early aeronaut by designing and constructing two bathyscaph vehicles, FNRS 2 and 3 prior to constructing the Trieste. The original Trieste was launched near Naples, Italy in 1953 and was named after the town of Trieste, Italy, whose townspeople contributed the funds for its construction.

¹Professor Piccard named his stratospheric balloon FNRS in honor of the Belgian National Fund for Scientific Research (Fonds National Belge de la Recherche Scientifique). His early research bathyscaphes FNRS 1, 2 and 3 were also named in honor of this fund.

²The approximate record height of 9.65 miles achieved on May 27, 1931 was then exceeded by Professor Piccard and Paul Kipfer who reached an official world record of 10.11 miles on August 18, 1932 (the United States later captured the world's altitude record with the "Century of Progress" balloon.

1-30. In 1957, Trieste I was evaluated by the U.S. Office of Naval Research, subsequently purchased, and assigned to Naval Electronics Laboratory (NEL), San Diego (now the Naval Underseas Center at Ballast Point, San Diego). The primary mission of the vehicle was to assist and support oceanographic research efforts of the U.S. Navy. The available expertise in the oceanic field, excellent weather conditions and the presence of numerous fleet activities made NEL and San Diego the most practical choice as the homeport of Trieste I.

1-31. Many tests programs and scientific projects were conducted during the next few years. Most significant of these was Project NEKTON in which Trieste I conducted a series of deep dives which were climaxed by a descent to 35,800 feet into the Challenger Deep. This abyss, the deepest known spot in the world's oceans had never been penetrated by any manned vehicle and the record set that day by Lt. Don Walsh and Professor Jacques Piccard (the son of Trieste's builder) still stands alone.

1-32. In March 1965, with a new float assembly installed, the redesignated Trieste II was transferred from NEL and placed under the control of the Commander Submarine Force, U.S. Pacific Fleet and the Deep Submergence Systems Project Office (DSSP).

1-33. The mission of Trieste II became the training of the naval officers and enlisted men as Deep Submersible Vehicle (DSV) operators and to further test and evaluate deep submergence concepts, equipment and sensors, with the following objectives:

1. Developing deep submersible search and operational techniques.
2. Developing deep submersible rescue vehicles and techniques.
3. Developing small object recovery methods.
4. Testing and evaluating prototype underseas equipment and oceanographic research tools.
5. Establishing preliminary training and qualification programs for DSV operators and support crew members.

1-34. In 1970, Trieste II was placed in overhaul in San Diego and extensively overhauled by Ships Force, Mare Island Naval Shipyard and was assisted by NUC, San Diego and various civilian contractors. After overhaul in the fall of 1970, Trieste was certified to dive to 12,500 feet. Trieste II was redesignated Trieste (DSV-1) at this time.

Table 1-4. Design Summary

DESIGN PARAMETER	SPECIFICATION
Design depth	20,000 feet (3,223 fathoms)
Length	78 feet
Width	15 feet
Draft (to landing gear)	21 feet
Weight (light)	88 tons
Displacement (submerged)	305 tons
Submerged endurance	12 hours at 2.0 knots 15 hours at 1.3 knots
Operating crew	3

1-35. MISSION PROFILE.

1-36. GENERAL. The following mission profile (or scenario) will assume a hypothetical deep wellhead servicing mission for the Trieste II which explores and encompasses the major modes and sequences possible during various phases of operation. This method of presentation is intended to familiarize the reader with the operational requirements and general capabilities of the equipment described in later chapters of this book. No attempt is made to provide detailed operational sequence of decision-making criteria, since this is available in other Trieste documentation or through normal command guidance.

1-37. It is conceded that any hypothetical approach to a complex deep ocean mission would understandably neglect some area of operation or preparation. However, it is felt that this method is justified as an invaluable training aid in establishing a baseline for learning the interrelated systems and operations (and men) that make a successful mission.

1-38. PREMISSION PLANNING. The hypothetical mission would begin with a review of all known facts concerning the servicing problem on the deep ocean wellhead and the general conditions in the intended work areas. Initial planning for Trieste II operations is conducted by the operational staff under the Chief of Naval Operations (CNO OP-23), which serves as the main contact point for the scientific or industrial communities, or other agencies interested in using the vehicle. Once planning is complete and a general plan of operations is formulated, the Commander-in-Chief, Pacific Fleet (CINCPACFLT) is notified and

Table 1-5. Personnel Qualified as Hydronauts

TRIESTE HYDRONAUTS	NAVY CERTIFICATION NO.
LT D. Walsh	1
LT L.A. Schumaker	2
CDR D.L. Keach	3
LT G.W. Martin	4
LCDR J.B. Mooney, Jr.	5
LCDR J.H. Howland	6
LT D.E. Saner	7
LT R.D. Waer	8
LT D.F. Helms	9
LCDR E.E. Henifin	10
LCDR R.F. Nevin	11
LT C.H. Staehle	12
LT J.B. Field	13
LT A.T. Dunn	14
CWO-2 L.E. Hawks	15
LCDR W.J. Leonard	16
LT R.E. Saxon	17
LT D.T. Byrnes	18
LCDR M.G. Bartels	24
LT R.H. Taylor	25
LCDR P.C. Stryker, Jr.	35
LCDR R.L. Abbott	45
LT R.D. Baker	48

the Commander Submarine Force, Pacific (COMSUBPAC) receives authorization to begin mission preparation. An operations order is then prepared and dispatched to the Commander, Submarine Development Group ONE (CSDG-1) in San Diego, California, where equipment and manpower preparations begin.

1-39. EQUIPMENT SELECTION AND PREPARATION. The standard equipment suite allows the Trieste II to perform her basic research and training mission. However, the vehicle's equipment carrying capabilities permit many variations of her basic

configuration. The equipment required for a particular project is dictated by many variables, including water depth (and total dive time), anticipated conditions at the wellhead site, and bottom topography relative to vehicle maneuvering in the work area.

1-40. The manipulator arm, shown in Figure 1-1 opening an access hatch in the wellhead, is part of the basic equipment suite, but other tools could be fitted to the manipulator to accommodate specific servicing or installation requirements.

1-41. The basic sonar suite (Chapter 4) on the vehicle satisfies most locating and maneuvering requirements. The vehicle could also carry and deploy four small BQN-8 deep ocean navigational transponders (DOT's) working in conjunction with the on-board navigation computer if the work assignment required a multiple location and navigation pattern on the bottom.

1-42. The availability of penetrators into the sphere and the multiplex system (Chapter 4) also greatly expands equipment suite capability of the vehicle. Salinity monitors, additional camera packages or other scientific equipment could be utilized to accomplish a specific task.

1-43. Once the equipment suite is selected, preparations are made for checkout and installation inboard and outboard of the vehicle. This phase of operations can be conducted in-transit (in the dock well, aboard the support ship - Chapter 7) or dockside in San Diego. Between missions, all Trieste II equipment is maintained in operational readiness through the regular U.S. Navy preventive maintenance system (PMS).

1-44. PROVISIONING. This phase of the mission involves the logistics of all project expendables, including AVGAS, ballast shot, compensating oil, handling lines, small boat (Bertram, hawser, and handling) fuel, nitrogen (for the AVGAS tank inerting system), photographic film, plotting paper, etc. These supplies are acquired, transported to the docking site, and stowed aboard the support ship (if the operation calls for normal support ship interface) or relayed by ship or air to a selected "jump off" location.

1-45. At this point, it should be noted that while the support ship docking/undocking procedure is preferred and used for most work or training projects, the vehicle and associated Fly-away Van support (Figure 7-10) could be moved "on-station" by other modes of transport. This flexibility allows the utilization of available cargo ships, air transport (of the vans, some equipment and crew) or many submarine tenders to accomplish the Trieste II support task.

1-46. TRANSIT. The transit phase aboard the support ship is normally used to ready the vehicle for its assigned task. The dock well of the support ship is specially outfitted (Figure 7-5 and 7-6) to accommodate and secure the vehicle during transit. Often, the long period of transit (if geography dictates) is put to good use for normal upkeep tasks on the vehicle. Prepermission equipment installation and total equipment checkout can be accomplished during this phase, if sea state and weather permit.

1-47. The compensating tanks (Chapter 2) are topped off during this phase; a vehicle bottom inspection is conducted; the camera equipment (both TV and film) are inspected and readied; transponders are readied if required; the sensor suite and electronic bottles are tested and checked; cable connectors are cleaned and checked; the oxygen bottles are charged and installed in the sphere; the life support system (Chapter 5) is tested; the batteries are charged; the AVGAS tanks inverted; and many other procedural items completed.

1-48. Work project planning and command instructions are also reviewed during transit. The Trieste crew is given final briefing on the task and the appropriate support ship complement is instructed in its role. Special briefing sessions are held between command functions of the vehicle and support ship to ensure efficient accomplishment of all work tasks.

1-49. The transit phase ends when the ship arrives on station. The amount of activity required during the next phase, Preundocking, depends largely on the amount of useable time available during transit. A transitional phase may be incorporated for the project if considerable navigation on the bottom is anticipated. Once on site, the support ship may be used to deploy transducers in a navigation grid for use with the vehicle's transponder interrogator system (TIS) (Chapter 4, 4-31). This phase is known as a grid survey and is accomplished through use of the support ship's satellite navigation system, LORAN (LONG RANGE Navigation) radio equipment, and a transponder interrogator system on the support ship. To assist in refining the grid survey, the vehicle may conduct a sound velocity profile check during one of the initial dives.

1-50. PREUNDOCKING. Once on station and prior to flooding the dock well in the support ship, the Trieste II engineering officer makes a final "walk-around" under the vehicle (much in the same manner as a flight engineer prior to take off) to check all systems and equipment. At this point in the operations, established post-upkeep/preundocking procedures are followed and checkoff lists are utilized to ensure that all critical and operational criteria are satisfied.

1-51. This phase also includes the rigging of hand lines to be used in the undocking phase, the readying of supply hoses, cabling and rigging for AVGAS, nitrogen, ballast shot, and communications; the attachment of the main tow line (Chapter 7, 7-14) to the vehicle and the stationing of the Trieste crewman in the sail of the vehicle to coordinate the actual undocking procedure.

1-52. The Bertram, hawser and Boston Whaler (handling) boats are also prepared and launched at this point in order to be standing by for immediate assistance during the undocking. The support ship diving detachment is also made ready during this phase for assistance in deflating the shock mitigation system in the vehicle landing gear, etc.

1-53. UNDOCKING AND PREDIVE. The actual details of the undocking procedure and towing preparations are presented in Chapter 7. They generally involve the flooding of the dock well (and lowering of the support ship stern) so that the hawser boat may slowly pull the vehicle clear of the support ship. When the vehicle is approximately 500 feet astern of the ship, the stern gate is closed,

the dock well is pumped out rapidly to maintain stability of the support ship, and a tow is established "into the sea" (Figure 7-4) approximately 150 feet astern of the ship. The "service line" or bundle of interface service connections between ship and vehicle is also connected at this time.

1-54. Final pre-dive preparations while the vehicle is in tow include the "topping off" and venting (Chapter 2) of the AVGAS tanks and washing down spilled (vented) gas with the fire hose connection from the ship; the unloading of shot ballast through the slurry line (Chapter 7); the checkout of all topside gear on the sail area of the vehicle. During this critical phase, a Trieste crew member is always stationed in the sail of the vehicle with either a sound-powered phone set (preferred) or an FM transceiver to coordinate operations. Another Trieste crew member (an electrician) is normally in the sphere conducting electronics, battery tests and "ballast" shot valve readings, etc., again, all in accordance with established pre-dive checkoff procedures. During this period, the diving detachment from the support ship is assisting by checking underside arrangements and opening the gates on the shot valves (Chapter 3).

1-55. At this point the pilot enters the sphere and lines up the life support equipment and powers up the equipment in final preparation for the dive. The pilot checks off all other pre-dive checklists to ensure that all systems are ready and calls for his co-pilot and navigator. When all are in the sphere and the hatch is dogged, the antechamber is flooded by the divers and tow is broken with the support ship. The pilot then gives the command and the divers vent the ballast tanks. While these are venting the diver also vents the all important main compensating valve (Chapter 2). The diver then swims away from the slowly descending vehicle and the dive phase is in process.

1-56. DIVE. This phase includes all surface-to-bottom-to-surface activity and begins when the vehicle clears the surface. The ballast tanks have been vented, are taking on water, the vehicle becomes negatively buoyant and begins its descent to the bottom. The vehicle is slow to clear the surface during the initial descent due to a pressure and temperature differential (AVGAS-seawater). Once the sail is submerged and the vehicle continues down, the descent rate is controlled to about 2.5 feet per second.

1-57. Descent. The first operation during the initial descent is to shift the topside UQC transducer (an omnidirectional unit) and establish communications with the surface ship controller (SSC), who is responsible to the Officer Tactical Command (OTC). If communications are not established immediately, the dive is aborted by dropping massive amounts of shot ballast. Communications are normally established simultaneously with the Bertram boat and the support ship at each 500 foot mark or 30-minute intervals during the descent. A communication loss in excess of 30 minutes could possibly initiate regular SUBMISS/SUBSUNK procedures to begin rescue attempts.

1-58. The pilot controls the vehicle's descent and attitude by "dropping shot" in 5-second bursts from the shot tub providing the desired control. If the vehicle is descending with a slight bow-down attitude, forward shot is dropped to "lighten" the bow upward and correct the angle. The descent rate is also slowed by dropping shot. This is the pilot's prime job during the descent.

Vehicle descent rate in the water column is determined with the computer pressure depth transducer system, but individual pilots utilize other "visual methods" of determining descent rate, including one pair of search lights illuminated to watch plankton pass by the viewing port.

1-59. If DOTs were deployed, the navigator operates the TIS (transponder interrogator unit) and begins plotting the vehicle's position in the DOT field relative to the location of the wellhead. If a sound profile is to be conducted, the co-pilot uses the voice recorder (Chapter 4) and reports conditions each 200 feet during descent. The co-pilot is occupied at this time with preparing to deploy the electronic suite. The major sensors are not normally turned on until nearing the bottom in order to conserve battery power.

1-60. The support ship uses a Straza, Model 7060, Transponder Interrogator Sonar during this phase to track the vehicle. The SSC maintains communication with the pilot of the vehicle throughout this phase. The surface ship controller is normally a qualified hydronaut with first-hand knowledge of the vehicle and its equipment. He makes recommendations as to movement of the support ship and attempts to maintain a position of 1500 to 2500 yards away from vehicle position. The Bertram boat remains directly over the vehicle's position by using on-board tracking sonar. In the event that communications and/or position of the vehicle were lost entirely, SUBMISS/SUBSUNK procedures are immediately initiated and all applicable forces of the U.S. Navy rescue team are deployed.

1-61. Bottom Approach. When the vehicle reaches approximately 1200 feet off the bottom, the shot ballast is dropped more rapidly to reduce the descent rate to approximately one foot per second. An ideal approach rate to the bottom for a soft landing is 2/10 of a foot per second.

1-62. Trail Ball Landing. The trail ball (Chapter 6) is a 250-pound lead ball on a cable and winch that is suspended approximately 18 feet to 30 feet (according to pilot preference) beneath the vehicle during final approach to the bottom. If the vehicle is trimmed correctly, the descent is almost stopped when the trail ball touches bottom. As the ball lands, the vehicle becomes 250 pounds lighter and greater control can be exercised during the final touchdown by "winching down" on the cable to the bottom. Landing on the ball rather than the landing gear offers another advantage; the silt on the bottom is not stirred up and visibility is preserved. The landing ends the descent phase of the dive.

1-63. Maneuvering and Control. During the approach to the bottom, the navigator is extremely busy establishing the vehicle's position within the designated search area. The best DOT information (if transponders were deployed) is provided as the vehicle is relatively high off the bottom, so the navigator is well aware of the vehicle's position within the established grid. If the vehicle is out of the desired position, the propulsion motors are energized and the vehicle is maneuvered in the water column (Chapter 6).

1-64. The present propulsion configuration (Chapter 6) does not provide for trainable motors; these are an expected vehicle modification in the near future (foundations and cabling are installed at this writing). The non-trainable propulsion motors presently on the vehicle provide the necessary maneuvering and

control capability for most conditions on the bottom, including navigation, maneuvering around or over bottom terrain features and hovering over a work area for camera or optical observation and evaluation of the wellhead work task (Figure 1-1).

1-65. Bottom Navigation. Vehicle navigation on the bottom is primarily conducted automatically through use of the Navigation computer and outboard sensor suite input to the computer. In the AUTO mode the transponder interrogator (also in AUTO) automatically interrogates the DOT's and sends data to the computer where the information is converted to appropriate propulsion and steering commands. An alternate mode is also available to the pilot in the event of skip zones, bottom bounce (and accompanying erratic ranges).

1-66. The alternate mode of bottom navigation involves manual interrogation of the DOT's, adjusting thresholds of the interrogator (Chapter 4) to determine valid ranging information, and manually inserting this data into the computer for automatic plotting on the X-Y plotter. The Mark 27 Gyrocompass and doppler sonar display is also available to the pilot and navigator for heading and velocity backup data during the bottom navigation phase.

1-77. Since the vehicle is only capable of a 3-knot speed, bottom currents present a problem to navigation toward the work area. The sonar suite gyrocompass output and the computer correct for these currents. The computer displays the heading directly from the gyrocompass and also displays the track made good.

1-78. The crew in the sphere also have available, the entire array of TV camera and searchlight coverage and visual observation through the view-port optical system to assist in navigation to the wellhead.

1-79. WORK TASK. The work task phase of our hypothetical project involves all operations, beginning with location and identification, and ending with the actual performance of the wellhead task. Our task involves retrieval and inspection of a down-hole safety valve within the wellhead enclosure.

1-80. Identification. The identification portion of the work task phase would entail the use of the entire sensor suite (TV cameras, film cameras and sonar) and optical viewing to ascertain that the wellhead was indeed the one within the subsea oil production field that required maintenance. Once the cameras are directed and the TV monitors viewed, communication with the SSC is addressed to the final determination of vehicle ability to perform any portion of the actual maintenance task.

1-81. Manipulator Arm. The manipulator arm (Chapter 6) provides the pilot with a variety of work capabilities on the bottom. The hydraulic actuation system (and mechanical advantage) provide great force capabilities at the jaws of the manipulator. A cutter blade is incorporated in the jaw design to allow cutting operations as well as normal handling capabilities. Special tool-handling capabilities are incorporated in the design which permit many difficult mechanical tasks to be accomplished.

1-82. As shown in Figure 1-1, the manipulator assembly (arm, elbow, wrist and jaws) is articulated to the extent that a variety of turning, pulling, lifting and pushing movements may be executed in performance of the task. The special tool-handling capability, coupled to the articulation of the overall assembly offers an extremely versatile tool in the hands of an experienced pilot.

1-83. During the maneuvering and work operations, great care is taken not to disturb the silt on the ocean bottom. Once the silt is disturbed, 40 minutes might be required for it to settle again to provide adequate visibility.

1-84. The final portion of the work task phase blends into the next phase of the mission upon completion of the maintenance on the down-hole safety valve. The ascent phase is commenced and communications are maintained at the regular 30-minute interval (or more often if required) during the entire bottom-to-surface excursion.

1-85. ASCENT. Prior to the actual ascent phase, the crew is extremely busy with regular vehicle checkoff procedures, including monitoring breathing gas, temperature, relative humidity, and CO₂ levels. If bottom work and conditions permit, this time could be devoted to a rest and eating period for the crew. Celery, due to its water content, is a favorite with the crew because of the low relative humidity maintained in the sphere. The rest and eating period might also be conducted immediately upon landing the craft on the bottom especially if silt conditions made a waiting period mandatory before work operations could be initiated.

1-86. Trimming the vehicle prior to ascent is the next part of the operation. This is almost a necessity if a level ascent attitude is expected. Once the ascent phase is cleared with the SSC, and all check-offs have been completed, trimming is initiated by dropping shot (forward or aft). The ascent is initiated by dropping just enough ballast shot to establish a desired rate of vertical control, usually about 5 to 8 seconds of shot (90 to 144 lbs). Shot dropping is monitored closely during this phase (Chapter 3).

1-87. During the ascent all non-essential systems are turned off and powering down of the sphere is commenced. It should be mentioned here that during the entire descent-ascent portion of the dive, the sphere is maintained at 1 atmosphere so that virtually no fluctuations in pressure is felt by the crew. At 100 feet from the surface, the antechamber blow system is energized and the access trunk is blown down. As a backup measure, this blowdown can also be accomplished by the Bertram tracking boat using high-pressure air flasks.

1-88. The ascent-phase ends with the vehicle breaking the surface. This can be accomplished at any time during a 24-hour period. When surfacing at night, sufficient lights are illuminated on the vehicle to ensure adequate visibility at and near the surface.

1-89. SURFACE OPERATIONS AND PRE-DOCKING. When the vehicle surfaces, the walking deck (Figure 1-2) is barely out of the water and a party of 3 to 4 divers boards the vehicle, immediately establishing sound-powered phone communication with the sphere. This is the first indication to the vehicle crew that they

have surfaced and have been located. The divers then proceed immediately to place locking pins in the shot control magnets and also to close the mechanical shot gates, so that all ballast control magnets (Chapter 3) can be de-energized to conserve battery energy.

1-90. If the dive is the last one in the mission, all shot would be dropped at the surface. It should be noted here that during an average dive to 4000 feet, 3600 pounds of shot (or 200 seconds @ 18 pounds per second) is dropped during the descent and, as already mentioned in paragraph 1-78, 90 to 144 pounds is dropped during the ascent for an average total of 3654 pounds. If other dives are planned, the ballast shot is preserved and topped off for the next dive. The shot tubs are always replenished before a second dive is initiated.

1-91. The Bertram tracking boat (equipped with two HP air flasks and a reducer) then comes alongside and the two end tanks of the vehicle are blown down. These are the two tanks that were flooded to gain negative buoyancy during the descent phase. This blowdown serves to raise the vehicle higher in the water so that the walking deck is not awash. At this point in the mission the crew leaves the sphere and electricians enter to take magnet and battery ground readings.

1-92. The next action is dependent on mission completion and entails either all preparations for docking the vehicle or establishing a tow (Chapter 7) and replenishing the AVGAS shot ballast and charging the batteries (8 to 10 hours charging time is required). If additional dives are planned, all pre-dive checkouts must be completed again prior to diving (paragraph 1-54). Predives are only valid for a 24-hour period and must be completed again if the period exceeds that limit to ensure safety and vehicle integrity.

1-93. Degassing or pumping the AVGAS back to the support ship would be the next step prior to docking the vehicle. Back filling of the AVGAS tanks with inerting nitrogen is accomplished simultaneously with the pumping evolution. After degassing is complete, up to 5000 gallons remain in the float. The AVGAS is extremely volatile and has a flash point of minus 45 degrees. All precautionary measures are taken to prevent any type of mechanical or static sparking (Chapter 2).

1-94. DOCKING. The detailed predocking and docking procedures are described in Chapter 7, including all support ship interfaces with the vehicle prior to actual docking in the well and the inflation of the shock mitigation system on the landing gear. When the vehicle has been winched into the dock well and the well pumped dry, the return transit phase begins.

1-95. RETURN TRANSIT. The return transit phase ends our hypothetical maintenance task on the subsea oil production wellhead. During the return transit, as in the initial transit to the search area (paragraph 1-50), the Trieste II crew is engaged in "all-hands" activity concerned first with pumping dry and defuming all AVGAS tanks and performing normal upkeep and PMS functions.

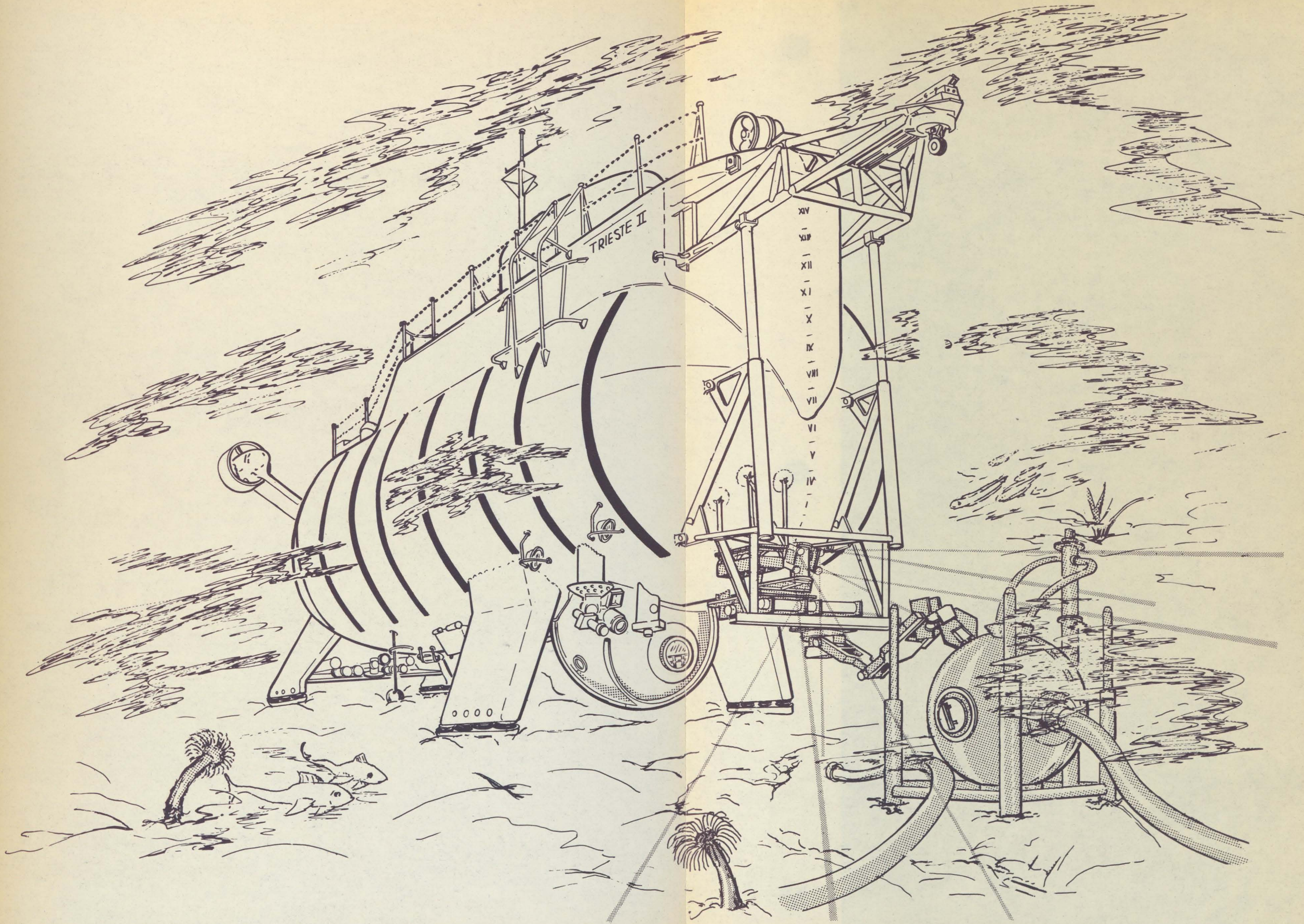

FIGURE I-1. TRIESTE II (DSV-1) SERVICING DEEP WELLHEAD

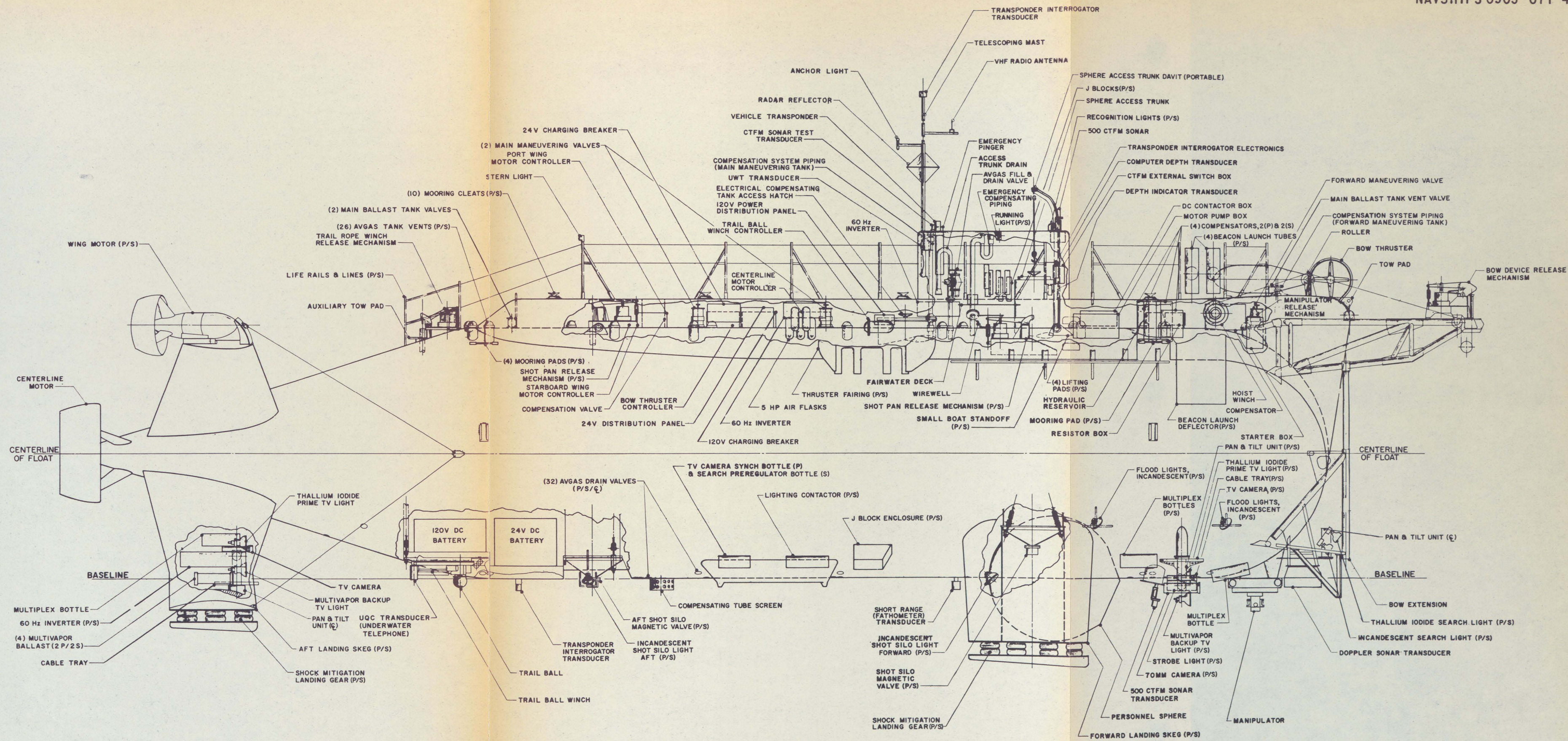

FIGURE I-2. TRIESTE II (DSV-I) EQUIPMENT CONFIGURATION

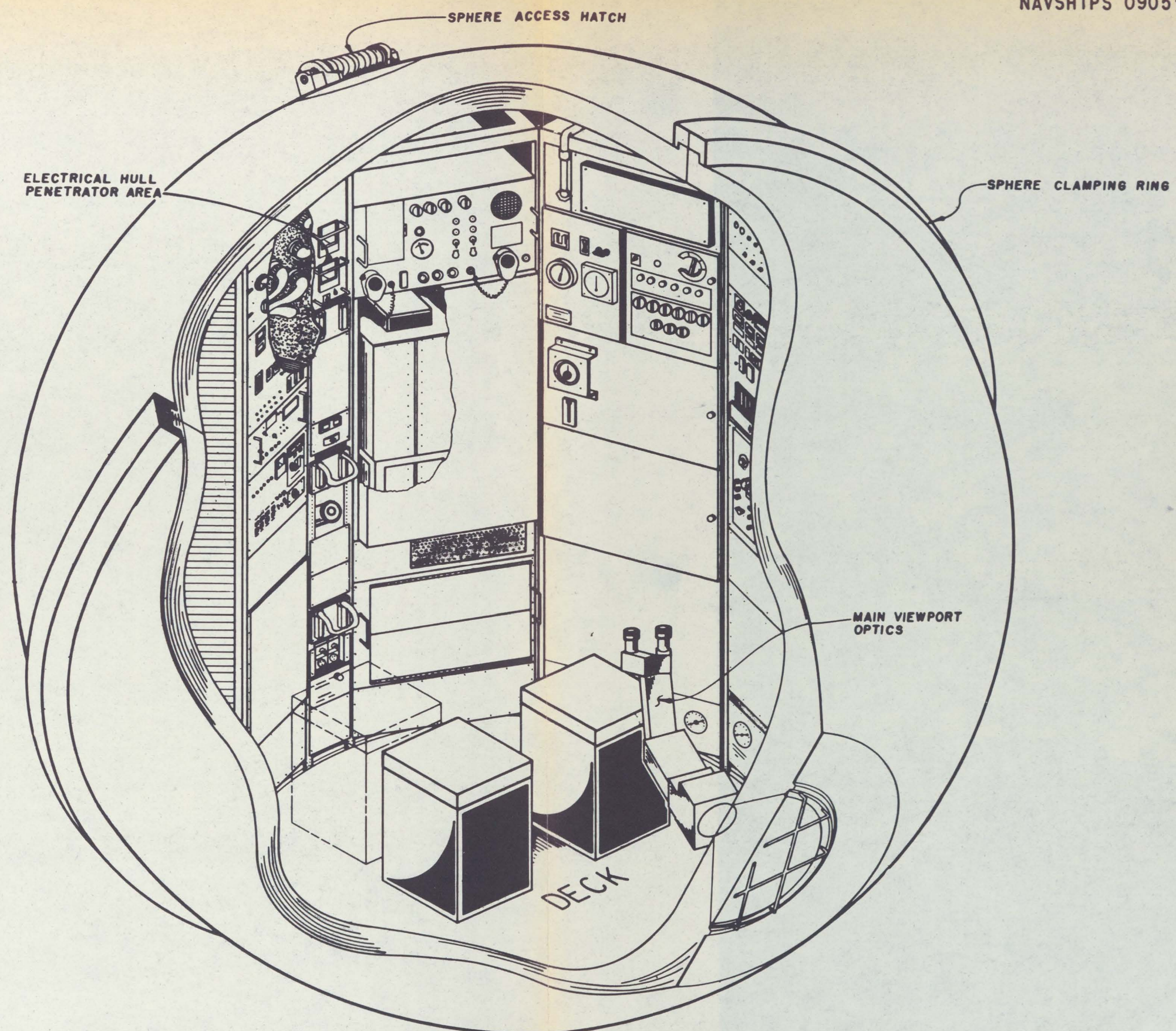

FIGURE 1-3. PERSONNEL SPHERE

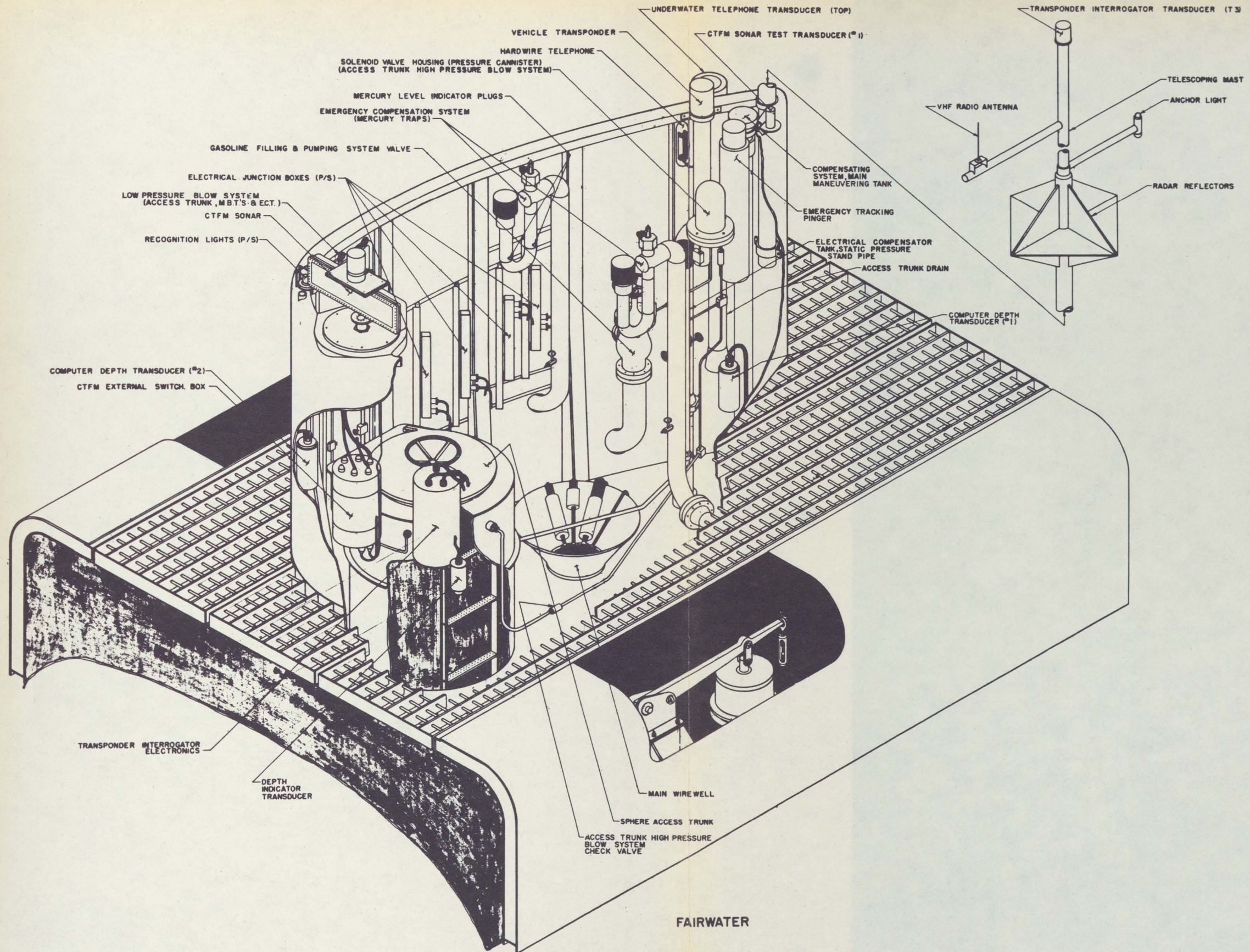
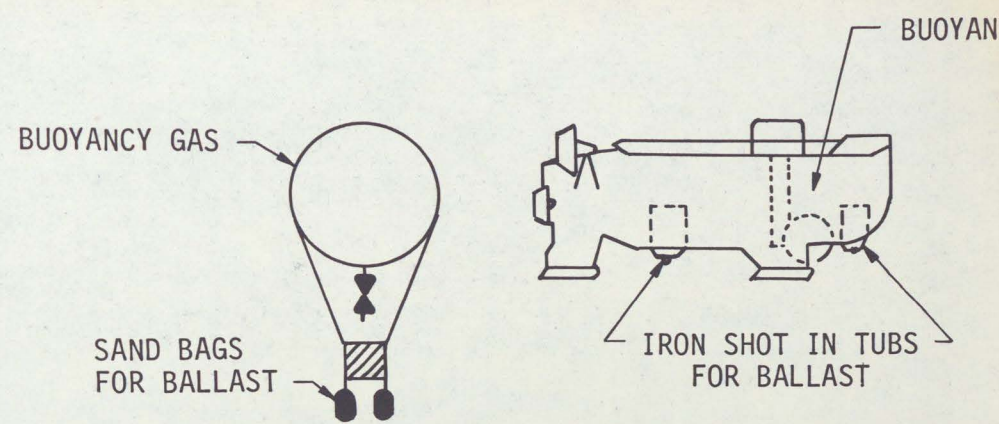

FIGURE 1-4. SAIL EQUIPMENT ARRANGEMENT



DROPPING BALLAST (WEIGHT) GAINS BUOYANCY AND VEHICLE ASCENDS

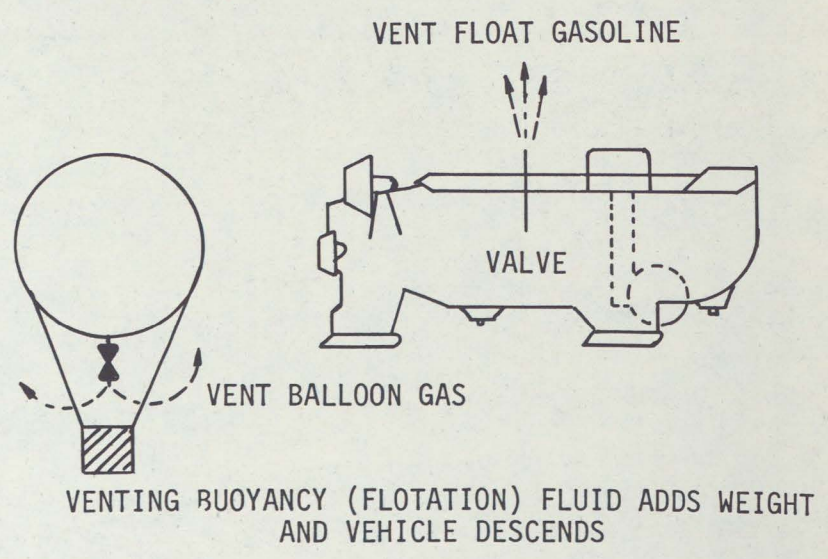
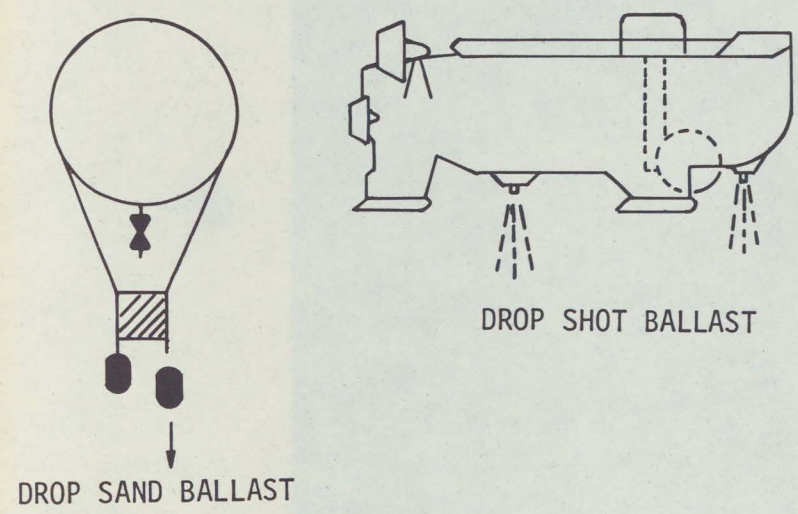

FIGURE 1-5. PRINCIPLES OF BATHYSCAPH OPERATION - BALLOON ANALOGY

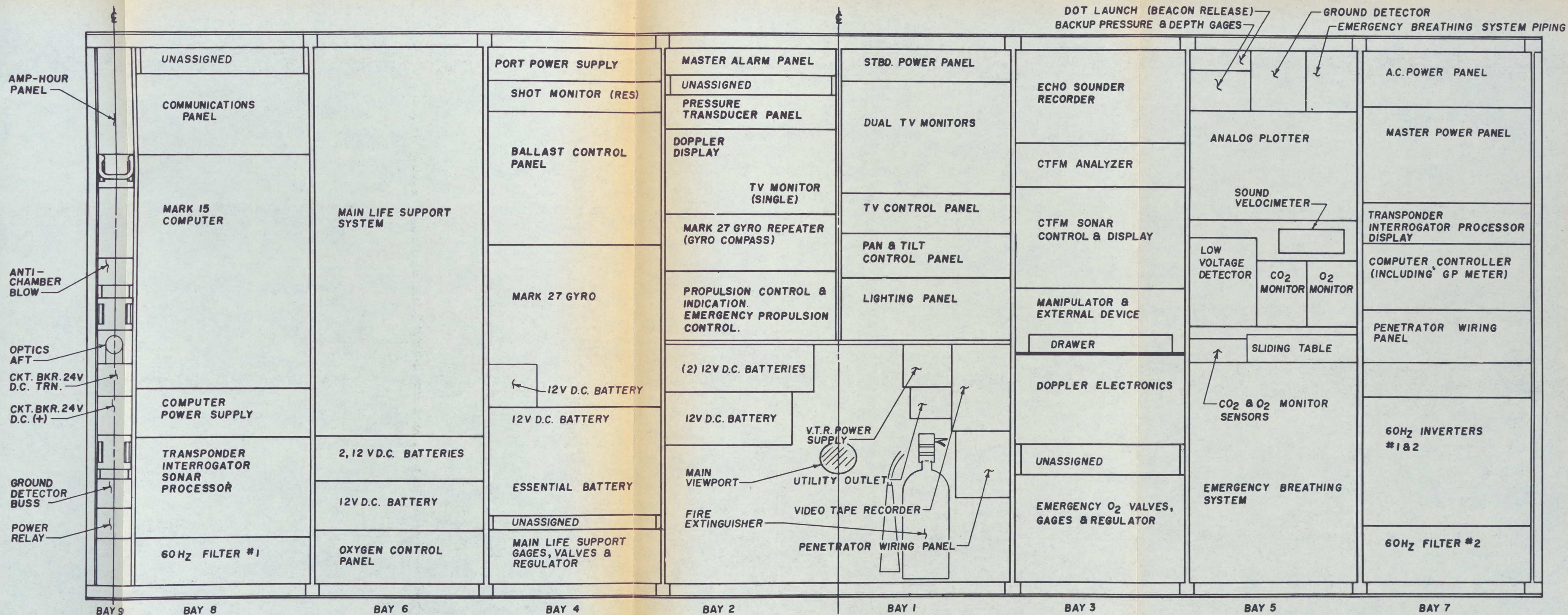

FIGURE 1-6. SPHERE CONTROL AND INSTRUMENT LAYOUT

PIPING

CHAPTER 2
PIPING SYSTEM

Number		Page
2-1.	Introduction	2-1
2-3.	Float Compensation System	2-1
2-11.	AVGAS Filling and Pumping System	2-3
2-21.	AVGAS Tank Vent and Drain System	2-5
2-30.	MBT, ECT and Access Trunk Blow and Vent System	2-9
2-40.	Access Trunk HP Blow System	2-10
2-50.	MBT, ECT and Access Trunk Flood and Drain System	2-11
2-61.	Nitrogen Inerting System	2-13
2-68.	Electrical Equipment Compensation System	2-14
2-90.	Shock Mitigation System	2-18

CHAPTER 2

PIPING SYSTEM

2-1. INTRODUCTION.

2-2. This chapter provides a detailed functional description for each of the ten subsystems comprising the Trieste II Piping System. A list of publications related to this system is included as an appendix to this SIB, and is offered as a source of additional reference material.

2-3. FLOAT COMPENSATION SYSTEM.

2-4. GENERAL DESCRIPTION. The hull structure of the vehicle is subjected to extremely high pressure differentials at operating depths. The float compensation system (Figure 2-1) is designed to provide safe and adequate pressure equalization between the aviation gas (AVGAS) contained within the hull structure and the crushing effect of the deep sea environment.

2-5. AVGAS TANKS - NORMAL COMPENSATION SYSTEM. Normal compensation for the AVGAS tanks is provided by a series of pipes or bulkhead holes which connects all the tanks to the main compensation tanks (5A and 5B). The bulkhead holes and piping are located low in the tanks in order to minimize loss of AVGAS in the event of a leak or a tear in the hull. Tanks 5A and 5B are designed to function as AVGAS and sea water interface reservoirs to avoid salt water contamination of the remaining tanks during normal underwater operations. Compensation for tanks 5A and 5B is normally accomplished by a pipe which runs from a low point in each of the tanks and connects to the compensation valve trunk. The compensating valve and valve trunk are described in paragraphs 2-8 and 2-9, respectively.

2-6. AVGAS TANKS - EMERGENCY COMPENSATION SYSTEM. The Emergency Compensation System is designed to function only if the normal AVGAS compensation system fails. This system consists of a pipe (one for each main compensation tank, 5A and 5B) running from a low point in each tank to a U-shaped mercury trap assembly located in the fairwater. The traps are filled with approximately 20 pounds of mercury designed to be expelled out of the trap (to sea or into the float) when the pressure differential between the AVGAS and sea water reaches a dangerous point and the normal compensating system fails to function. Once the mercury has been expelled from the trap, the emergency compensation piping provides an unobstructed passage for free circulation of sea water, thus restoring equilibrium.

2-7. MANEUVERING TANKS. Two maneuvering tanks are provided on the vehicle, the main (midship) tank and a second forward tank. The main maneuvering tank, as designed, represents over 11,000 pounds of buoyancy. Since two maneuvering

valves are available, this tank was subdivided with a partial bulkhead at the centerline pipe. This subdivision does not compromise the tank capabilities and reduces the maximum possible loss to approximately 6,400 pounds rather than 11,000 pounds. The maneuvering tanks (main and forward) are not compensated through the compensation valve and main compensation system. Each tank is provided with a compensation pipe, which consists of an open-ended standpipe running from a low point in the tank, through the tank boundary, to an accessible area above the waterline.

2-8. COMPENSATING VALVE. This special valve is basically of simple double check design, consisting of two movable disks (upper and lower) located directly over each other. Each disk is positioned over its own seat by an arrangement of four adjustable springs. The valve is designed to provide adequate pressure equalization flow, while protecting against the siphoning effect that would occur if a leak developed in any given AVGAS tank. Valve operation is automatic and requires no control during the course of underwater operations. The lower disk admits water to the float on descent, or such other time as flow-in is caused, and is loaded to ~ 1.9 psig. The upper disk relieves the float of water on ascent, or such other time as internal pressure causes flow-out, and is loaded to ~ 0.4 psig. A tank fracture would not draw water in by the upper disk, as return flow causes it to close.

2-9. AVGAS COMPENSATING TRUNK AND VALVE COVER. These components are an integral part of the compensating valve system. The compensation valve cover is approximately 19 1/2-inches high by 18 inches in diameter and is designed to fit over the compensation valve assembly. The valve cover is bolted to its own collar foundation and forms a watertight part of the compensation valve system. The compensation valve trunk is a fabricated Monel pipe that runs from a hull liner at the bottom centerline of the hull up through a hull liner at the top centerline of the hull, where it is flanged for mounting to the feeder tube assembly. The feeder tube assembly is open to sea, allowing two-way flow of seawater through the compensating valve and providing pressure equalization for the AVGAS tanks.

2-10. MANEUVERING VALVE. Three electromagnetic valves are provided for operator control of the main and forward maneuvering tanks (main tank-top frame 14; main tank-top frame 19; forward tank-top, aft frame 2). The valves are controlled from the sphere and consist of a ported housing, a valve seat, a weighted magnetic core (including the seat gasket) and an electromagnet. When the electromagnet is energized, the magnetic core is drawn upward lifting the seat gasket off the valve seat and venting the AVGAS in the tank to sea. When de-energized, the weight on the magnetic core will return the seat gasket to a positive closed position. When AVGAS is vented through the maneuvering valves it is replaced by sea water which enters the tank via the compensation pipe. This action causes the tank to become heavier and provides the operators with an effective trim system for the submerged vehicle.

2-11. AVGAS FILLING AND PUMPING SYSTEM.

2-12. GENERAL DESCRIPTION. This system provides a means for filling and pumping the AVGAS for the buoyancy, compensation, and maneuvering tanks. When used in conjunction with the vent system and the portable nitrogen inerting system, the system allows for filling and pumping (gassing and degassing) the vehicle with a minimum amount of the dangers normally encountered during handling of AVGAS. Figure 2-2 shows the piping and valve network of the system. Chapter 7 describes the total interface between the support ship and the vehicle.

2-13. PREPARATION FOR FILLING AND PUMPING. Prior to transferring AVGAS to or from the vehicle, the following services are required between the vehicle and the support ship:

1. Ground cable (electrical) firmly attached between hull structures.
2. Communication (sound-powered telephone) wire.
3. Low pressure air hose.
4. Fire hose.
5. AVGAS hose (4 inches).
6. Nitrogen inerting hose - 1 inch (degassing only).

Services 1 through 4 above are lashed together and handled as a single bundle. The remaining services are handled separately.

2-14. AVGAS FILLING AND PUMPING. AVGAS is supplied to the tanks through the main 4-inch AVGAS valve located in the fairwater. This valve is arranged so that the 4-inch AVGAS supply hose from the support ship can be connected from outside the fairwater. The AVGAS is fed from this valve through a run of 4-inch ips pipe to the special manifold assembly, located on the starboard side of the ship just aft of the fairwater. The various AVGAS piping runs are distributed from this manifold through individual sight glass assemblies to the tank shut-off valves. These valves are located where the pipe runs turn and penetrate the hull into the tank. Once in the tank, the piping extends down to a point about 2 inches above the hull. This low position of the pipe opening serves to minimize the loss of AVGAS in the tank if the shut-off valve is left open (or leaks) and also allows the maximum amount of AVGAS to be taken out of the tanks during the pumping down process.

2-15. The special manifold, the sight glasses, and the tank shut-off valves are all located between the superstructure walking deck and the hull. The shut-off valves are accessible for operation through the use of portable

sections of the superstructure grating. A special adapter (Reference 3 - Special Fittings) is provided to couple the end of the supply hose to the main 4-inch AVGAS valve. The adapter is specially fitted to allow for gaging the pressure during gassing. The adapter also allows for venting off the system after gassing or degassing in order to clear the hose of AVGAS and minimize spillage.

2-16. INERTING THE FLOAT. During any docked period, the float is normally opened for access and all of the tanks are filled with air at atmospheric pressure. If AVGAS were to be introduced into these tanks, an extreme fire hazard would result. In order to reduce this hazard, it is necessary to provide an atmosphere with reduced oxygen content prior to gassing. This is accomplished by enriching the atmosphere with nitrogen gas (inerting) to a point where fire risk is reduced. Inerting is normally completed in the well of the support ship prior to undocking.

2-17. DEGASSING THE VEHICLE. The complete degassing procedure is divided into four phases: Pumping out, stripping, residual drain, and ventilation of the float. Pumping out is normally accomplished with the vehicle afloat, astern of the support ship, while remaining steps are normally completed after docking. The maximum flow rate with both support ship pumps operating is approximately 350 gpm. During pumping out procedure the tanks are inerted with nitrogen gas.

2-18. While it is theoretically possible to strip AVGAS to a residual of about 400 gallons, a more practical minimum, due to pitch and roll, is in the order of 3000 gallons. For docking purposes, it is desirable to reduce the residual figure as low as possible; however, it is not considered dangerous from a structural standpoint to dock with as much as 6000 gallons remaining in the float.

2-19. Since the drain valves are on the bottom of the float, the vehicle must be docked and secured for sea before the draining of residual AVGAS is commenced. After draining, the float is essentially dry of liquid AVGAS with only small pockets of water and AVGAS remaining. The atmosphere is basically inert with mostly nitrogen blanketing all tanks. If necessary, the float can be maintained in this condition for an indefinite period. However, if any work is to be done inside the tanks or any significant work is to be done around the vehicle, all traces of AVGAS and fumes must be removed from the float. The float is ventilated by introducing a large quantity of air to evaporate the remaining AVGAS and purge all fumes.

2-20. MATERIALS. All the material for the filling and pumping system is designed to be non-sparking. The valves and piping are CuNi and the associated fittings are CuNi, Monel aluminum or brass. All connecting joints in the system are welded and dye penetrant inspected to insure against possible leaks.

2-21. AVGAS TANK VENT AND DRAIN SYSTEM.

2-22. GENERAL DESCRIPTION. AVGAS tank vent and drain system (Figure 2-3) provides a means to inert, vent, and drain the buoyancy, compensation and maneuvering tanks. The system is designed to operate in conjunction with the AVGAS filling and pumping system and the portable nitrogen inerting system.

2-23. AVGAS TANK VENT SYSTEM. An arrangement of vent valve assemblies allows (inerting) nitrogen to be first introduced and then expelled from the various tanks during the AVGAS filling process. The vent valves also serve to supply the tanks with nitrogen during the pumping down procedure. Each vent valve assembly, located as shown on Table 2-1, consists of three component assemblies:

1. The dome cover assembly
2. The plug cock valve assembly
3. The dome compensating assembly

2-24. Dome Cover Assembly. This assembly consists of a dome (or cap) which is threaded to a base plate on the tank (Figure 2-1) and serves to enclose the vent valve. The assembly acts as a secondary boundary to protect against loss of AVGAS in the event the valve leaks or is inadvertently left in the open position. A lanyard-jack chain prevents overboard loss of the dome.

2-25. Plug Cock Valve Assembly. This assembly consists of 1-inch IPS plug cock valve mounted to the dome cover base plate. The tops of all the vent valves are located at the same elevation (15 feet-6 7/8 inches ABL) so that all the tanks fill with AVGAS at about the same time. When this assembly is located on the top of the hull at centerline, the dome cover base plate is welded directly to the hull. When the arrangement requires that the assembly be installed either to port or starboard of centerline, then a 6-inch IPS steel trunk is provided in order to maintain the required elevation. This trunk is welded to the hull structure and the dome cover base plate is welded to the top of the trunk.

2-26. Dome Compensating Assembly. This assembly (Figure 2-3) consists of a length of synthetic rubber hose plugged at each end with a Monel insert and clamped with a standard CRES hose clamp. A welded nipple connects one of the plugs through the underside of the dome cover base plate, providing a compensation flow path from the rubber hose to the dome enclosure. The complete assembly hangs down into the AVGAS tank and is kept filled with seawater. As the pressure in the AVGAS tank increases, the rubber hose will be compressed, forcing sea water through the nipple into the dome chamber and providing compensation.

2-27. AVGAS TANK DRAIN SYSTEM. An arrangement of drain valves is provided for removing residual AVGAS from tanks after the pumping down process has been accomplished. Each drain valve is located (Table 2-2) to allow for maximum amount of AVGAS removal from the tanks when the vehicle is docked within the support ship. The drain valve is designed to eliminate the possibility of AVGAS being spilled into the dock area.

Table 2-1. AVGAS Tank Vent Valve Locations

TANK NO.	LOCATION
Fwd Man Tk	6-5/8 in AFT FR 2, 4 in OFF CL PORT
TK 1B	7-1/2 in AFT FR 5, 2 ft 10-5/8 in OFF CL PORT
TK 1A	9-5/8 in FWD FR 6, 2 ft 10-5/8 in OFF CL STBD
TK 1C	2 in AFT FR 6, TOP CL OF HULL
TK 2B	4 in FWD FR 9, 3 ft OFF CL PORT
TK 2A	9-3/8 in FWD FR 9, 2 ft 10-5/8 in OFF CL STBD
TK 2C	6 in FWD FR 13, TOP CL OF HULL
TK 3B	6 in AFT FR 13, 2 ft 10-5/8 in OFF CL PORT
TK 3A	8 in AFT FR 13, 2 ft 10-5/8 in OFF CL STBD
TK 3C	4-1/4 in AFT FR 13D, TOP CL OF HULL
TK 4B	4-1/4 in AFT FR 13D, 2 ft 10-5/8 in OFF CL PORT
TK 4A	4-1/4 in AFT FR 13D, 2 ft 10-5/8 in OFF CL STBD
TK 4C FWD	2-3/4 in AFT FR 18, TOP CL OF HULL
TK 4C AFT	5 in AFT FR 15, TOP CL OF HULL
TK 5B	4-1/8 in FWD FR 19, 3 ft 1-1/2 in OFF CL PORT
TK 5A	4-1/8 in FWD FR 19, 3 ft 1-1/2 in OFF CL STBD
TK 5C	2-7/8 in AFT FR 23, TOP CL OF HULL
TK 6B	7 in FWD FR 22, 2 ft 10-5/8 in OFF CL PORT
TK 6A	7 in FWD FR 22, 2 ft 10-5/8 in OFF CL STBD
TK 6C	7 in FWD FR 27, TOP CL OF HULL
TK 7B	2-5/8 in AFT FR 26, 3 ft 3-1/8 in OFF CL PORT
TK 7A	2-5/8 in AFT FR 26, 3 ft 3-1/8 in OFF CL STBD
TK 8B	9-3/4 in FWD FR 27, 2 ft 10-5/8 in OFF CL PORT

Table 2-1. AVGAS Tank Vent Valve Locations (Continued)

TANK NO.	LOCATION
TK 8A	9-3/4 in FWD FR 27, 2 ft 10-5/8 in OFF CL STBD
TK 9B	7 in FWD FR 27, 1 ft 6 in OFF CL PORT
TK 9A	7 in FWD FR 27, 1 ft 6 in OFF CL STBD

Table 2-2. AVGAS Tank Drain Valve Locations

TANK NO.	LOCATION
FWD MAN. TK	10 in AFT FR 2, BOTTOM CL OF SHIP
TK 1A	5 in FWD FR 4, 2 ft 9 in OFF CL STBD
TK 1B	5 in FWD FR 4, 2 ft 9 in OFF CL PORT
TK 1C	4 in AFT FR 4, BOTTOM CL OF SHIP
TK 1C	3 in FWD FR 6, BOTTOM CL OF SHIP
TK 2A	4 in AFT FR 6, 2 ft 9 in OFF CL STBD
TK 2B	2 in FWD FR 6, 2 ft 9 in OFF CL PORT
TK 2C	6-1/2 in FWD FR 7, BOTTOM CL OF SHIP
TK 2C	11 in AFT FR 12, BOTTOM CL OF SHIP
TK 3A	9-1/2 in AFT FR 13, 2 ft 9 in OFF CL STBD
TK 3B	7-1/2 in AFT FR 13, 2 ft 9 in OFF CL PORT
TK 3C	9-1/2 in AFT FR 13D, BOTTOM CL OF SHIP
TK 4A	9-1/2 in AFT FR 13D, 2 ft 9 in OFF CL STBD
TK 4B	9-1/2 in AFT FR 13D, 2 ft 9 in OFF CL PORT
TK 4C	4-1/2 in FWD FR 14, BOTTOM CL OF SHIP
TK 4C	7-1/2 in AFT FR 18, BOTTOM CL OF SHIP

Table 2-2. AVGAS Tank Drain Valve Locations (Continued)

TANK NO.	LOCATION
TK 5A	17-5/8 in AFT FR 18, 2 ft 9 in OFF CL STBD
TK 5B	17-5/8 in AFT FR 18, 2 ft 9 in OFF CL PORT
TK 5C	1-1/2 in FWD FR 21, BOTTOM CL OF SHIP
TK 5C	10-3/8 in AFT FR 20, BOTTOM CL OF SHIP
TK 6A	10 in AFT FR 22, 2 ft 9 in OFF CL STBD
TK 6B	10 in AFT FR 22, 2 ft 9 in OFF CL PORT
TK 6C	1-1/4 in FWD FR 29, 7 in OFF CL STBD
TK 6C	1-1/4 in FWD FR 29, 7 in OFF CL PORT
TK 7A	4-7/16 in AFT FR 26, 2 ft 9 in OFF CL STBD
TK 7B	4-7/16 in AFT FR 26, 2 ft 9 in OFF CL PORT
TK 8A	10-3/8 in AFT FR 26, 2 ft 9 in OFF CL STBD
TK 8B	10-3/8 in AFT FR 26, 2 ft 9 in OFF CL PORT
TK 9A	6 in FWD FR 31, 2 ft 9 in OFF CL STBD
TK 9A	3 in AFT FR 32, 3 in OFF CL STBD
TK 9B	6 in FWD FR 31, 2 ft 9 in OFF CL PORT
TK 9B	3 in AFT FR 32, 3 in OFF CL PORT

2-28. LOW PRESSURE VENTING. The low pressure vent system is used to remove all remaining residual AVGAS from the tanks. The system is designed to prevent any concentration of AVGAS fumes from being present within the dock well area of the support ship. Major components comprising the system are:

1. N₂ Piping and Hoses - Used to distribute defuming air from the support ship to all AVGAS tanks.
2. Residual AVGAS Drain Hoses - These are portable connections between the AVGAS tanks and the accumulator tank.
3. Special Hose Adapter - Allows the accumulator tank to be coupled with an 8-inch ventilation hose which carries AVGAS fumes to an air driven booster fan and over the dock wall.

2-29. MATERIALS. All the materials for these systems are designed to be nonsparking, except the hose clamps used in the dome compensation assembly. The dome cover assembly and tank vent valves are made of bronze, while the mounting nipple and dome cover base plate are Monel. All the welds or brazed joints are dye penetrant inspected to insure against leaks.

2-30. MBT, ECT & ACCESS TRUNK BLOW AND VENT SYSTEM.

2-31. GENERAL DESCRIPTION. This system (Figure 2-4) provides a means to blow down and vent the ballast tanks, the access trunk, and the electrical compensation tank (ECT). The system is designed to function with the flood and drain system.

2-32. BLOW DOWN SYSTEM. Air for this system is supplied from the support ship or tracking boat to a valve manifold arrangement located high inside the fairwater on the starboard side of the vehicle. This arrangement allows the operator to distribute air to any desired tank while standing on the walking flat inside the fairwater.

2-33. BALLAST TANK PIPING. This line consists of a CuNi pipe which runs from the fairwater valve manifold assembly to the forward and aft ballast tanks, and serves only to supply air to blow down the tanks. A removable screen is provided at the tank penetration to keep foreign matter out of the piping system. The tanks are blown dry by closing the vent valves and forcing the seawater out the flood hole at the bottom of the tanks.

2-34. ACCESS TRUNK PIPING. This line consists of a seamless CuNi pipe which runs from the fairwater valve manifold assembly, through the trunk structure and down to the sphere walking flat. This pipe serves to supply air to blow down the access trunk in case the HP system fails to function. This pipe is threaded at the outlet end (inside the access trunk) for installation of a modified pipe cap. A 3/16-inch diameter hole is drilled through the pipe cap and serves to reduce pressure within the trunk during the blow down procedure.

WARNING

This cap reduces the danger of blowing out the sphere collar gasket and must be installed before diving.

2-35. When the vehicle is surfaced, the pipe cap may be removed and a hose assembly installed to provide ventilation to personnel working in the sphere. The access trunk is blown dry by closing the hatch and forcing the seawater out through the drain pipe.

2-36. ELECTRICAL COMPENSATION TANK PIPING. The ECT tank is blown dry by low pressure air supplied by piping from the fairwater valve manifold assembly. The drain valve is opened by means of a reach rod and low pressure air drives the seawater out the drain valve.

2-37. BALLAST TANK VENTING. Venting for the forward and aft main ballast tanks (MBT) is accomplished through a ball valve located at the high point in each tank. A special valve handle (in the aft tank only) which extends through the superstructure and can be pinned in either the open or closed position, is provided for the aft MBT vent valve. These valves are opened to flood the tanks and are closed to blow the tank dry.

2-38. ACCESS TRUNK VENTING. This procedure is accomplished by opening the access trunk personnel hatch, which will vent the trunk during flooding. No valve assembly is provided.

2-39. ELECTRICAL COMPENSATION TANK VENTING. Venting of the ECT is accomplished by opening the vent valve located inside the fairwater which allows the air to escape from the tank through the standpipe.

2-40. ACCESS TRUNK HP BLOW SYSTEM.

2-41. GENERAL DESCRIPTION. This high pressure (HP) air system (Figure 2-5) allows the operators within the sphere to blow down the sphere access trunk without contact or assistance from the Support Ship. This function is of primary importance, since the operators cannot leave the sphere after the vehicle has surfaced, until the water in the trunk is blown out. The system is designed to function with the flood and drain system. Five HP air flasks, each with a volume of 246 ft³ at 3000 psi, are available for blow down.

2-42. BLOW DOWN PROCEDURES AND COMPONENTS. The access trunk is routinely blown down with the HP air system via valve AHP-1. Prior to access trunk blowdown, plugs for the drain lines must be removed, and the access trunk hatch and flood valve must be closed. The trunk then becomes a confined space and can be blown down via the drain line at the bottom.

WARNING

Blow down of the access trunk during ascent and/or prior to surfacing is not recommended. Due to construction requirements, the access trunk gasket is tested for 12 psi differential pressure. Blow down during ascent could result in the gasket being subjected to excessive pressure.

2-43. When the vehicle has surfaced, HP blow down may also be accomplished from the fairwater by manual operation of valve AHP-2 or with LP air from the tracking boat.

2-44. The calculated time to blow down the access trunk with HP air is less than four minutes. The HP blow system, including all components, is designed to withstand full submergence pressure and consists primarily of the following component assemblies:

1. A pressure proof valve housing and an arrangement of distribution valves and connecting tubing.

2. A bank of HP air flasks and connecting tubing located between the hull and superstructure deck.

3. A blow line from the valve housing to the sphere access trunk, including a water check valve located under the walking flat in the fairwater.

2-45. HP Air Flask Assembly. A total of five flasks are installed to store air for blowing down the sphere access trunk. The flasks are mounted in a foundation with the discharge end located in the down position. This allows condensation to be blown out of the flasks during operation. The outlet ends of the flasks are connected together into a single line which runs forward and into a two-way distribution valve (AHP-2) inside the fairwater.

2-46. Sphere Access Trunk HP Blow Line. This consists of a single line which runs forward from motor-driven control valve AHP-1, which is located inside a pressure-proof housing in the fairwater portside. A HP water check valve (AHP-8) is installed in this line to check back-flow of seawater and protect the air check valve (AHP-4) and the HP control valve. Installed at the bulk-head fitting inside of the sphere access trunk is a special orifice plug, sized to restrict the flow of high pressure air from the flasks. This is necessary to protect against blowing out the sphere collar gasket during the blow down process.

2-47. Blow down is accomplished by introducing high pressure air into the top of the sphere access trunk and forcing the water out the bottom of the trunk through the drain piping.

2-48. Portable HP Charging Assembly. This charging assembly consists of a stop valve (AHP-5), a filter and a bleed-off valve (AHP-3), which are mounted on a portable board. The unit is designed to be installed in the fairwater, near the valve housing and the distribution valve arrangement. High pressure air is then supplied from the support ship through a HP hose and quick-disconnect assembly at the portable board.

2-49. Portable HP Gage Assembly. This gage assembly is used during the charging procedure and consists of a bleed-off valve (AHP-7) and a high-pressure gage connector which are mounted on a portable board. The unit is designed to be installed in the fairwater, near the valve housing and the distribution valve arrangement.

2-50. MBT, ECT & ACCESS TRUNK FLOOD AND DRAIN SYSTEM.

2-51. GENERAL DESCRIPTION. This system provides a means to flood and drain the ballast tanks, the electrical compensation tank and the sphere access trunk. This system is designed to function with the low pressure (LP) air blow and vent system, and the high pressure (HP) air blow system.

2-52. FORWARD AND AFT MBT FLOOD AND DRAIN SYSTEM. These tanks are flooded and drained by an 8 3/4-inch diameter hole located at the bottom of each tank on the centerline of the ship. A screen is provided to prevent foreign

matter or debris from entering the tank. A portable flood hole cover can be installed by a scuba diver if it becomes necessary to seal off the tank from the sea.

2-53. Flooding is accomplished by opening the tank vent valve allowing air to escape from the top of the tank. This allows seawater to flow into the tank through the flood hole. The draining procedure requires that the vent valve be checked closed and that the blow valve be opened. This allows air pressure into the tank and forces the seawater out through the open flood hole.

2-54. ELECTRICAL COMPENSATION TANK (ECT) STATIC PRESSURE SYSTEM. This system consists of an acrylic standpipe that ties into the ECT blow pipe. When the vehicle is surfaced, the standpipe allows a positive pressure to be maintained on the compensation bags which are located inside the ECT. This system is isolated by valve V-6 during the ECT blow down procedure.

2-55. ECT FLOOD AND DRAIN SYSTEM. A single valve which is located at the bottom of the tank is used to flood and drain the ECT. No screen is provided for this system because the valve opening is considered small enough to keep out most foreign matter or debris which might cause damage. A portable plug can be installed by a diver if the valve fails or must be removed for routine maintenance.

2-56. Flooding is accomplished by opening a vent valve and allowing the air to escape from the tank. This allows seawater to flow into the tank through the flood valve. The draining procedure requires that the static pressure valve be checked closed and that air be supplied back into the tank via the vent valve V6. This allows air pressure into the tank and forces the seawater out through the flood valve.

2-57. ACCESS TRUNK FLOOD AND DRAIN SYSTEM.

2-58. Flood System. The access trunk is flooded by an angle ball valve located in the walking flat. A strainer is provided to prevent foreign matter or debris from entering the trunk and drain piping. A portable flood valve cover is not provided for this system because the valve inlet is inaccessible when the sphere is in place. However, a blind flange is provided for installation to the valve flange in case of leakage while the vehicle is surfaced. This valve is operated by a flexible cable assembly which allows control of the valve through the hatch opening at the top of the access trunk.

2-59. Draining requires that air be introduced into the trunk using either the LP or HP air system as described in paragraphs 2-34 and 2-37. This forces the seawater out the bottom of the trunk, through the drain hoses, and up the drain piping to the overboard gooseneck in the fairwater.

2-60. Drain System. The access trunk drain system consists primarily of two hoses and pipe runs from the bottom of access trunk, joined together within Tank 2C and reduced down to one main pipe which runs up through the top of the hull into the fairwater. The main drain pipe within the fairwater is shaped in a

gooseneck to minimize seawater from splashing back in the system while the vehicle is surfaced and subject to sea state. Flexible hoses are used to couple the drain system between the sphere recess fitting and the sphere collar fitting. The hoses allow the sphere to move without rigid restriction. Portable plugs are provided for installation into the drain outlets (within the sphere collar) when the vehicle is surfaced. This prevents debris from dropping into the hoses and also keeps water out of the trunk in case the hoses leak. The drain system is open to sea during descent and ascent to provide pressure compensation for the access trunk enclosure during submerged operations of the vehicle.

2-61. NITROGEN INERTING SYSTEM.

2-62. GENERAL DESCRIPTION. This system is used to provide a protective blanket of inerting nitrogen gas within the buoyancy, compensation and maneuvering tanks during the AVGAS filling or pumping process. Due to the danger encountered in the transfer of AVGAS, it is imperative that the inerting system be utilized during the process. The overall system consists of a portable network and a permanently installed network. Nitrogen for the system is provided from the support ship through a quick disconnect supply hose. See Figure 2-6.

2-63. PORTABLE NITROGEN INERTING SYSTEM. This system consists of two assemblies and is connected between the support ship and the permanent inerting network on the vehicle.

2-64. Pressure Regulator Assembly. This assembly consists of a quick disconnect nipple, a cut-off valve (AI-9), a 40-mesh strainer, and a pressure regulating valve (AI-9). The pressure regulator is adjusted to maintain 3.3 +0, -.5 psig regulated pressure with 86 ± 14 psig inlet pressure. Nominal flow capacity of the regulator is 60 scfm. Connection of the regulator assembly to the permanently installed nitrogen distribution manifold is facilitated by a 1 1/4-inch ips union.

2-65. Relief Valve Assembly. This assembly contains a 0-5 psig pressure gage, a manual vent valve (AI-8), and parallel relief valves (AI-6 and -7). The relief valves are set at 3.5 psig and each will handle the full nitrogen flow rate at less than 4 psig. Rated flow capacity is 65 scfm for each relief valve at 4 psig inlet pressure.

2-66. PERMANENT NITROGEN INERTING SYSTEM. The permanent inerting system is a fixed piping network containing a distribution manifold (N_2) with two 1 1/4 inch union ports for connecting the relief and regulator assemblies of the portable system. The LP air supply for AVGAS tank ventilation attaches to the same N_2 manifold connection used for the portable pressure regulator.

2-67. The fixed piping of the system is divided into four zones, each equipped with a separate cutout valve (AI-1 through -4). The zones and tank grouping are identified in Table 2-3. The supply branches (zones 1, 2, 3, and 4) terminate in hoses connected to a fitting. The hoses are connected to the tank vent valves by a quick-disconnect coupling and 90-degree threaded

elbow, which is screwed into the top of the vent valves. The free end of the hose is attached to a deck support when not in use. Prior to the tank inerting operation, each hose is attached to the adjacent tank vent valve. There are 26 tank vent valves used to inert the float tanks.

Table 2-3. Nitrogen Inerting System - Tank Zone Identification

ZONE 1	ZONE 2
1. Tank 1A 2. Tank 1B 3. Tank 1C 4. Tank 2A 5. Tank 2B 6. Fwd Man. Tk	1. Tank 2C 2. Tank 3A 3. Tank 3B 4. Tank 3C 5. Tank 4A 6. Tank 4B
ZONE 3	ZONE 4
1. Tank 4C (Fwd) 2. Tank 4C (Aft) 3. Tank 5A 4. Tank 5B 5. Tank 5C 6. Tank 6A 7. Tank 6B	1. Tank 7A 2. Tank 7B 3. Tank 8A 4. Tank 8B 5. Tank 6C 6. Tank 9A 7. Tank 9B

2-68. ELECTRICAL EQUIPMENT COMPENSATION SYSTEM.

2-69. GENERAL DESCRIPTION. This compensation system is designed to equalize sea pressure and temperature on electrical equipment located within thin skin (non-pressure-proof) enclosures. Each enclosure and its respective compensator is filled with a dielectric fluid which transmits the sea pressure sensed at the compensator, to the inside of the enclosure. Sufficient fluid is provided in each system to satisfy pressure and temperature volume changes to 20,000 feet, plus an ample safety margin. Figure 2-7 shows a typical arrangement for the system.

2-70. SYSTEM ARRANGEMENT. There are 16 ship's service electrical compensator systems and 5 appendage compensator systems. Fourteen of the ship's service systems use nylon reinforced rubber compensators (bags) located in the electrical compensator tank (ECT). The remaining two ship service systems are identified as the battery compensators. These units are stainless steel cylinders located in the aft main ballast tank. The five appendage units include the Westinghouse Bow Winch (Unit 763), DC Contactor Box (Unit 764), Manipulator Motor Pump Box and Hydraulic Reservoir (Units 781 and 790, and the Sperry

Trail Ball Winch). The bow winch and DC contactor box each use metal bellows compensators. The manipulator uses three piston type devices. The appendage compensator systems are covered in detail in paragraph 2-84.

2-71. SHIP'S SERVICE COMPENSATOR SYSTEM. The electrical equipment compensation system uses a nylon reinforced rubber compensator, or bag, to sense the pressure of the seawater and transmit this pressure to the 1-centistoke silicone fluid inside the system. Each compensator unit measures approximately 5.5 inches in diameter by approximately 56 inches in length; total volume is 1215 in³.

2-72. The system is designed to produce a slight overpressure inside the electrical enclosures under normal operating conditions. The overpressure is accomplished by utilizing the difference in the specific gravities of silicone fluid and seawater. The internal overpressure is 0.09 psig per foot between the bottom of the compensating fluid and the electrical equipment enclosure. Whenever the vehicle exceeds an up angle of about 6.65 degrees, the centerline propulsion motor (the worst case) will experience a slight negative differential pressure. This should not present any serious problems since it has been demonstrated that the centerline motor can experience a negative 5 psig differential pressure and still maintain watertight integrity.

2-73. The physical arrangement of the compensator bags in the electrical compensation tank controls the amount of overpressure in a particular system. This fact dictates the bag location relationship to each system. The water/fluid differential head pressure makes this system ideally suited to the fully submerged environment. Surface operations require that a water head be provided to maintain an overpressure while on the surface. Paragraph 2-54 describes the electrical compensation tank static pressure system.

2-74. BATTERY COMPENSATION SYSTEM. The battery compensators use Marcol 52 (dyed blue) as the compensating fluid. The compensators use a direct seawater interface which is necessary because of the large volume that must be compensated. The level of seawater in the compensators will rise from its entry point in the bottom to approximately 50% of its length at a depth of 20,000 feet.

2-75. The physical location and arrangement of the battery compensator was dictated by the extreme weight of the batteries. It was therefore necessary to mount the compensator above the batteries. At maximum depth, the calculated negative pressure differential for the batteries is about 0.9 psi. Since all seals are static, however, this should not cause a problem. Figure 2-8 is a diagram of the compensation system.

2-76. COMPENSATION SYSTEM IDENTIFICATION AND DESCRIPTION. Tables 2-4 and 2-5 following this paragraph identify and describe the compensator systems in the ECT and aft MBT. The DSV-1-504-1705280 Plan is also referenced for further identification and location of system components.

Table 2-4. Rubber Compensators Located in the ECT

SYSTEM	DESCRIPTION	SYSTEM CAPACITY IN ³	REMARKS
EC-A	Bow Thruster Motor	6100	With additive
EC-B	Port Motor	6140	With additive
EC-C	Stbd Motor	6140	With additive
EC-D	CL Motor	6200	With additive
EC-E	BAT BRKR - 24V	6740	
EC-F	24V Chg CB	5180	
EC-G	120V Chg CB	4900	
EC-H	BAT BRKR - 120V	6600	
EC-J	CL Motor Control	6280	(2) Comp Bags
EC-K	Port Motor Control	6500	(2) Comp Bags
EC-L	Stbd Motor Control	6440	(2) Comp Bags
EC-M	Bow Thruster Control	6300	(2) Comp Bags
EC-N	24V Dist Pnl	10920	(2) Comp Bags
EC-P	120V DIST Pnl	1858	

Table 2-5. Battery Compensators Located in the Aft MBT

SYSTEM	DESCRIPTION	SYSTEM CAPACITY IN ³	REMARKS
BC-S	24V Battery Comp System	32380	With dye
BC-R	120V Battery Comp System	34290	With dye

2-77. FLUIDS USED FOR ELECTRICAL COMPENSATION.

2-78. Definition.

1. Flash point - Lowest temperature at which the fluid will give off sufficient vapor to ignite momentarily when a flame is applied to the vapor.

2. Fire point - Lowest temperature at which the vapors given off will burn continuously.

2-79. Characteristics of Fluids.

1. Battery Comp oil Marcol 52 (dyed blue):

- a. Specific gravity @ 77°F = 0.821
- b. Viscosity @ 100°F = 7.5 centistokes
- c. Flash point = 330°F

2. Silicone Fluid, Mil Spec VV-D-1078:

- a. Specific gravity @ 77°F = 0.818
- b. Viscosity @ 77°F = 1.0 centistokes
- c. Flash point = 100°F
- d. Boiling point = 320° F

3. Hydraulic Fluid MIL-H-5606B (Manipulator):

- a. Specific gravity = 0.89
- b. Viscosity @ 130°F = 10 centistoke
- c. Flash point = 200°F

2-80. Basic Safety Considerations.

1. Avoid spills. Use adequate containers or drain lines to collect fluids when emptying any compensated unit.

2. Use no sparking tools.

3. Use the LP air supply to ventilate and sustain ventilation into the ECT whenever entering this space.

4. Containers should be stored in properly ventilated spaces.

2-81. Toxicology.

2-82. Silicone fluid and Marcol 52 present no handling problems in normal industrial practice either from the standpoint of skin irritation or accidental ingestion. Fluid which contacts the eyes produces only a slight temporary discomfort and essentially no irritation.

2-83. The hydraulic fluid used for this application is a petroleum base material. Prolonged contact with this material should be avoided. Care should be exercised to prevent contact with the eyes.

2-84. APPENDAGE COMPENSATION SYSTEM. Compensation systems for the manipulator, bow winch, trail ball winch and bow systems (DC Contactor box and Resistor box)

are covered in the following paragraphs. Figure 2-4 shows the piping and relationship between major components of each system.

2-85. Manipulator Compensation System. The manipulator system is composed of two separate compensator systems. One system is filled with approximately 40 gallons of 1-centistoke silicone fluid (VV-D-1078) and supplies compensation fluid from two 750 in³ piston compensators to motor-pump box (unit #781). The second system is filled with approximately 9 gallons of hydraulic fluid (MIL-H-5606) and supplies compensation fluid to hydraulic reservoir (unit #780) from a single 750 in³ piston compensator.

2-86. The piston units are designed to apply a positive fluid pressure by means of a spring. The internal operating pressure range provided by the spring tension is 2 psig minimum to 20 psig maximum above the external ambient pressure at any point within the piston travel.

2-87. Bow Winch Compensation System. The bow winch assembly is compensated independently by a 1300 in³ bellows assembly which is filled with about 30 gallons of 1-centistoke silicone fluid (VV-D-1078).

2-88. Trail Ball Winch Compensation System. This pressure compensating fluid system is of the closed-circuit, pressure-equalized type. The system operates to maintain a pressure approximately 14 psi above the submerged environment. A bellows acts as a pressure equalizer, and a spring maintains a positive internal oil pressure to the gear box, the electric motor, switch box, and load cell housings. Two relief valves, set at 15 psig, are used to prevent excessive oil pressure buildup in the system.

2-89. Bow Systems Compensation System. The bow systems consists of the DC Contactor Box (unit 764) the Resistor Box (unit 746) and a bellows-type Compensator (unit 747). The DC contactor and resistor boxes are compensated from the 5000-in³ (displacement) bellows compensator. The total system is filled with 114 gallons of 1-centistoke silicone fluid (VV-D-1078). The bellows exerts a positive pressure to the fluid, preventing any leakage of seawater into the compensator.

2-90. SHOCK MITIGATION SYSTEM.

2-91. The landing gear on the vehicle is equipped with a shock mitigation system which consists of inflatable air mounts "Air Ride" fitted between the bottom of the gear and a landing shoe. Four of the mounts are located in each of the forward port and starboard landing gear, and three each in the aft port and starboard landing gear (lower stabilizers). The air mounts are used to cushion the vehicle's landings during docking and also to reduce the chances of damage to the stabilizers during undocking.

2-92. Low pressure (100 psi) air from the support ship is used by the divers (Figure 2-10) to inflate the air mounts. With the vehicle astern of the ship

(or in the dock) divers control the supply and vent valves to inflate the mounts until the space between the landing gear and shoe is extended to seven inches. This approximates the ideal pressure setting for the system. Prior to diving, the air mounts are deflated by the divers.

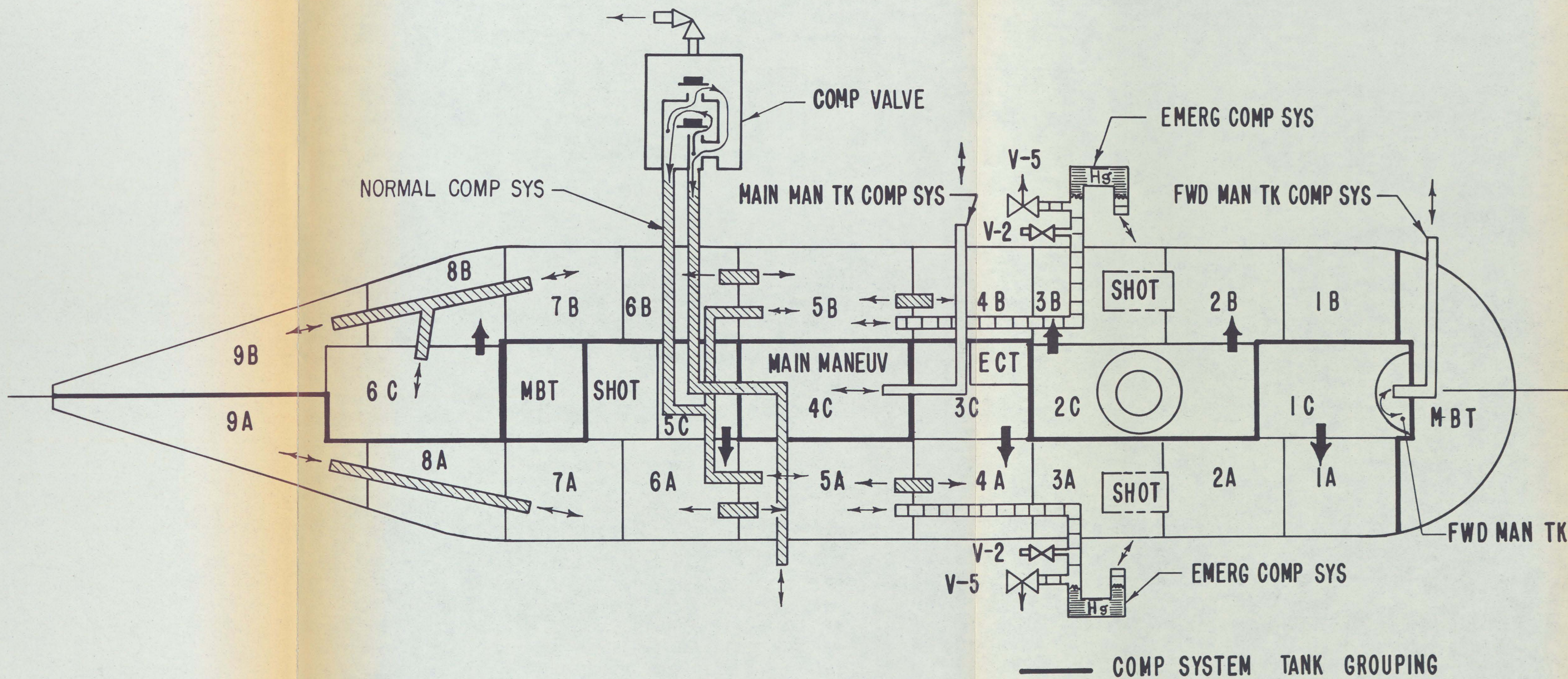
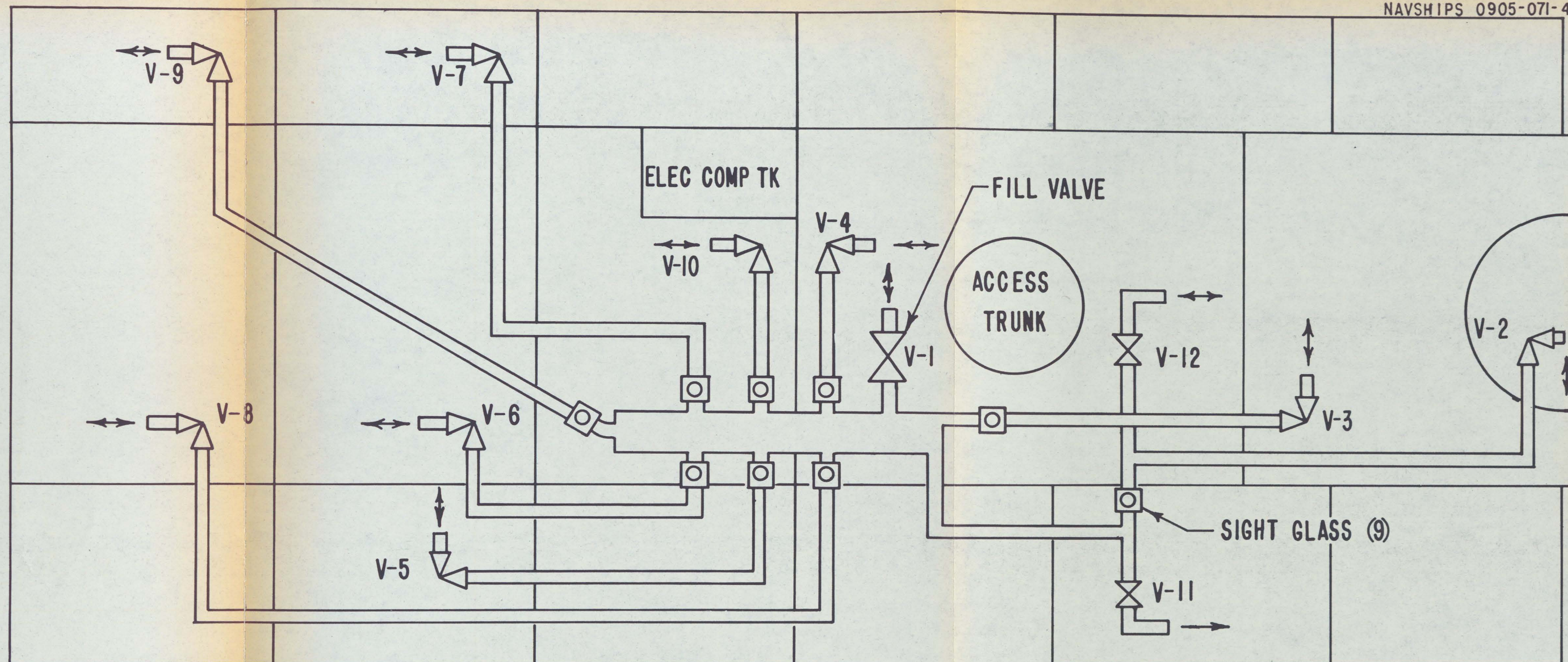

FIGURE 2-1. FLOAT COMPENSATION SYSTEM



VALVE SERVICE LIST

VALVE NO.	TANK NO.
V-8	5C, 6A, 7A, 8A & 9A
V-9	6B, 7B, 8B, 9B & 6C
V-10	1C, 1A, 2A, 3A, 4A & 3C
V-11	STRIPPING CONNECTION
V-12	1B, 2B, 3B, 4B & 2C

VALVE SERVICE LIST

VALVE NO.	TANK NO.
V-2	FWD MANEUVERING TANK
V-3	1C, 1A, 2A, 3A, 4A & 3C
V-4	1B, 2B, 3B, 4B & 2C
V-5	5A
V-6	4C
V-7	5B

FIGURE 2-2. AVGAS FILLING AND PUMPING SYSTEM

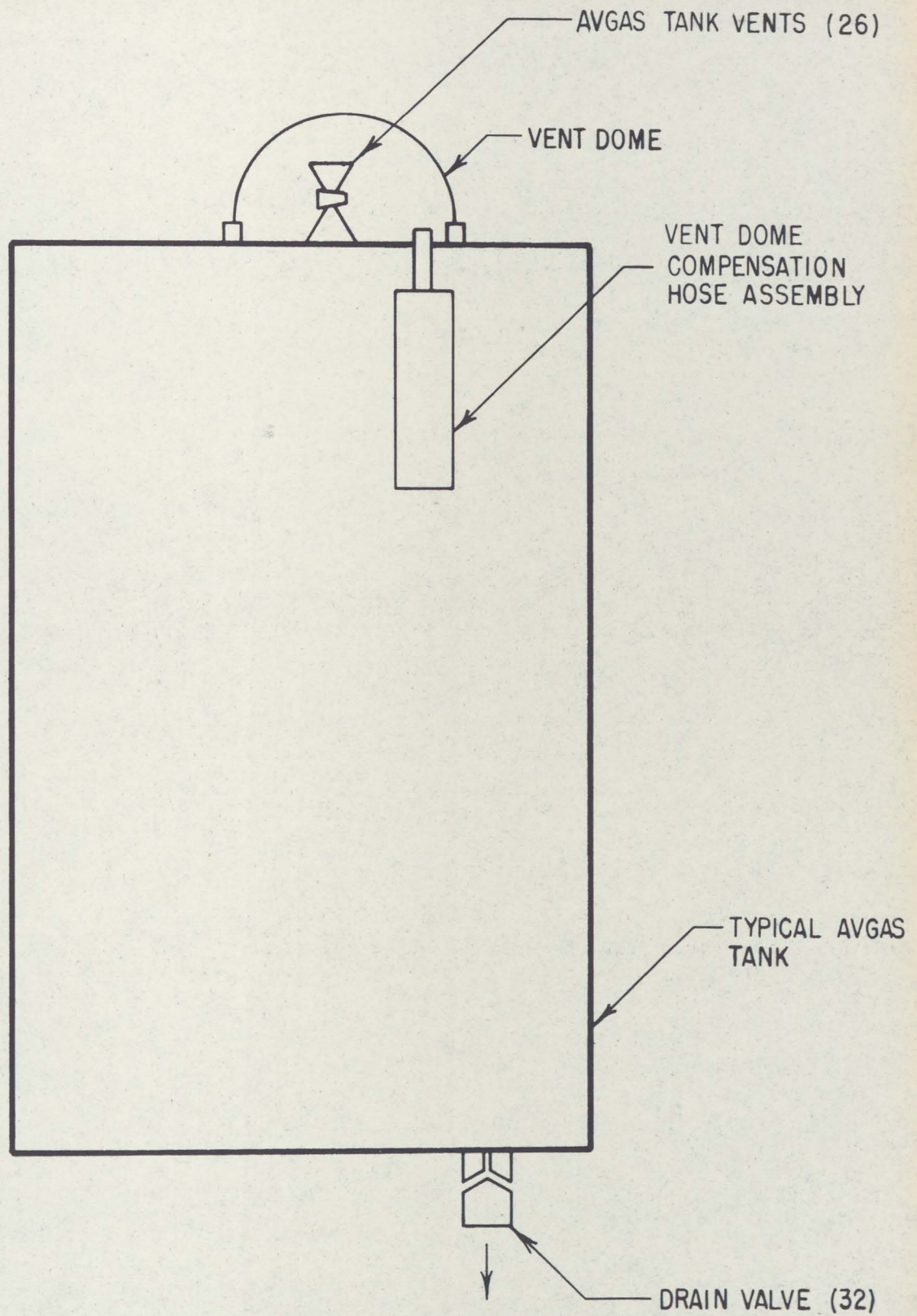

FIGURE 2-3. AVGAS TANK VENT AND DRAIN SYSTEM

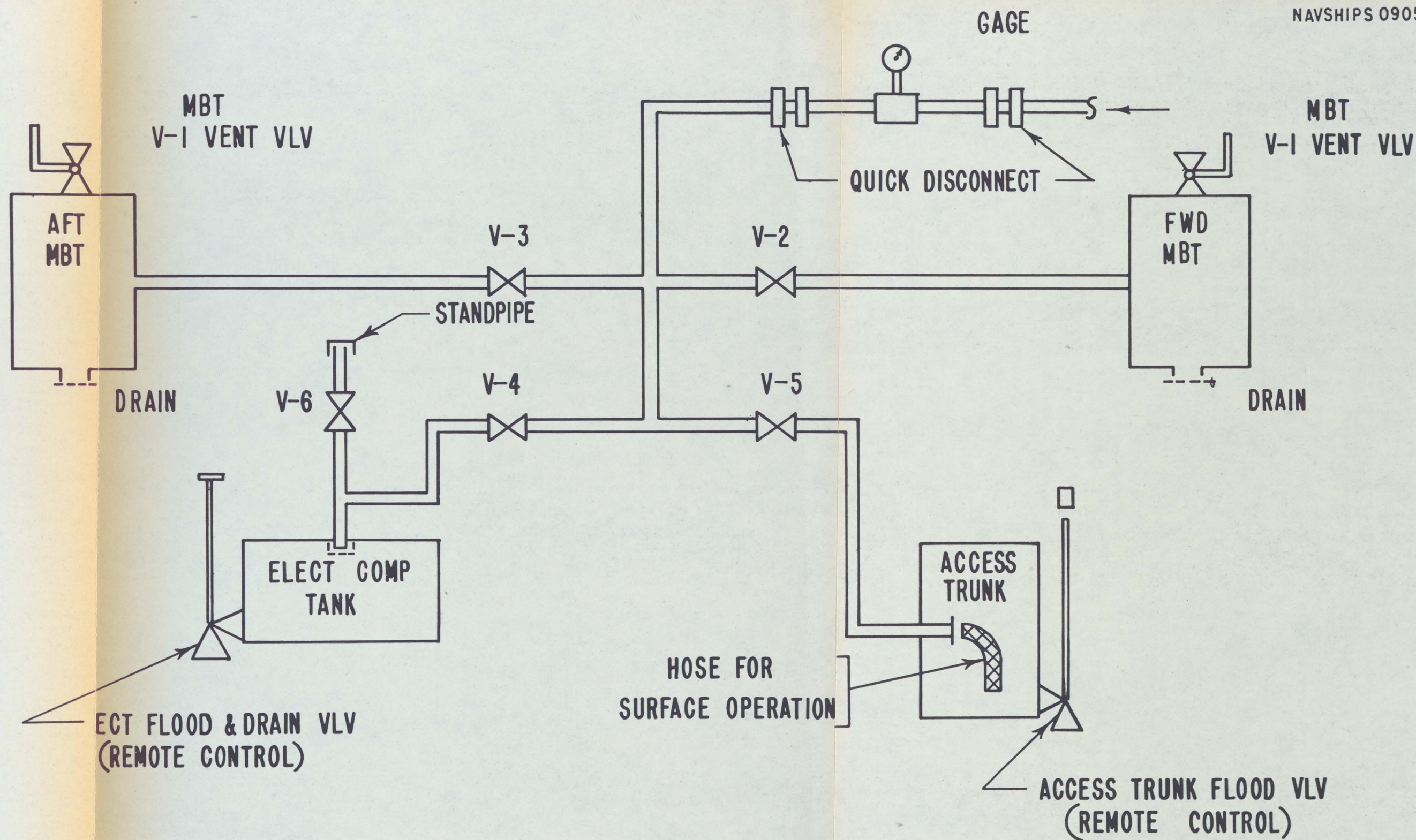

FIGURE 2-4. LP BLOW AND VENT SYSTEM, AND MBT VENT AND DRAIN SYSTEM

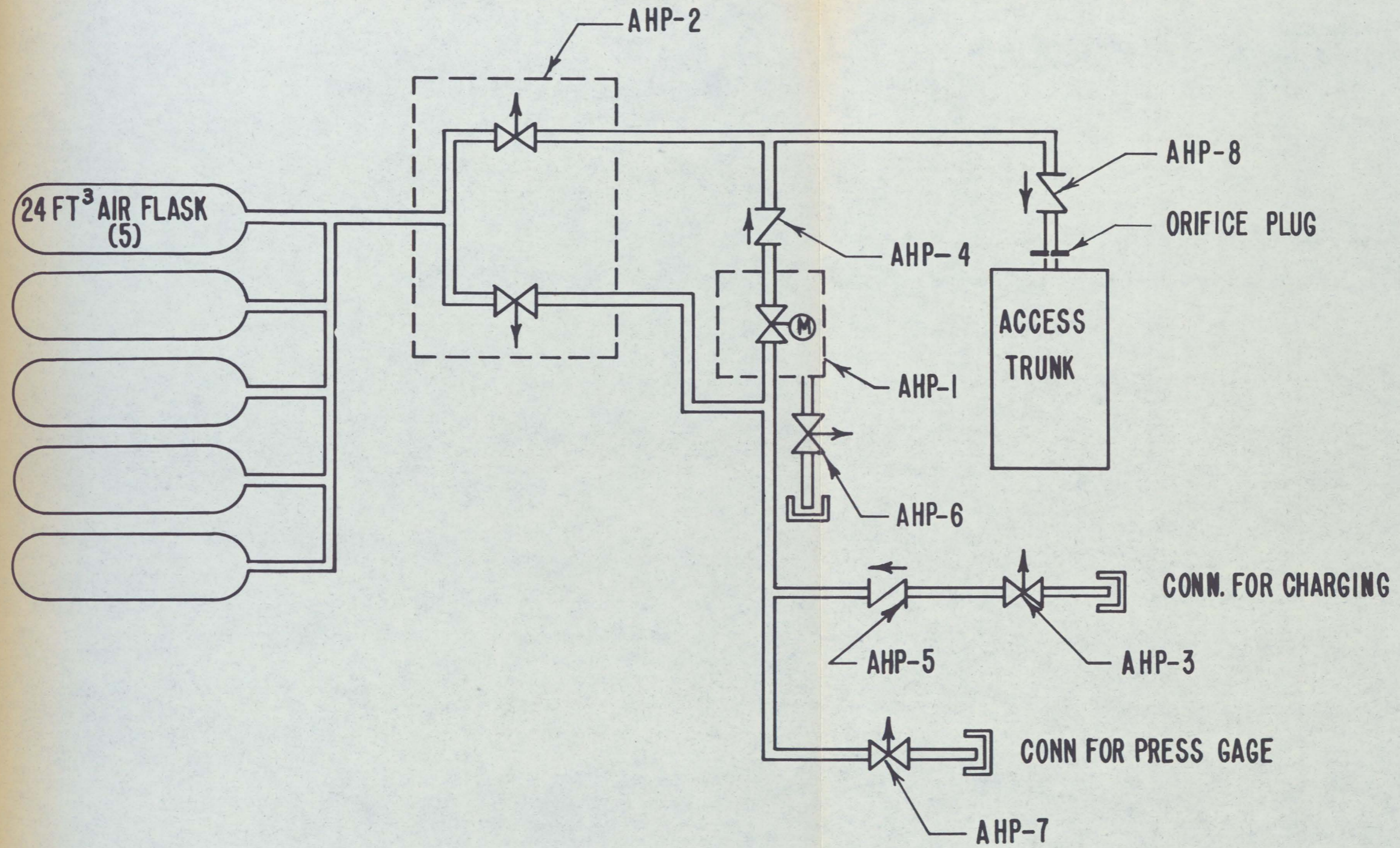

FIGURE 2-5. HP AIR SYSTEM
(3000 PSI)

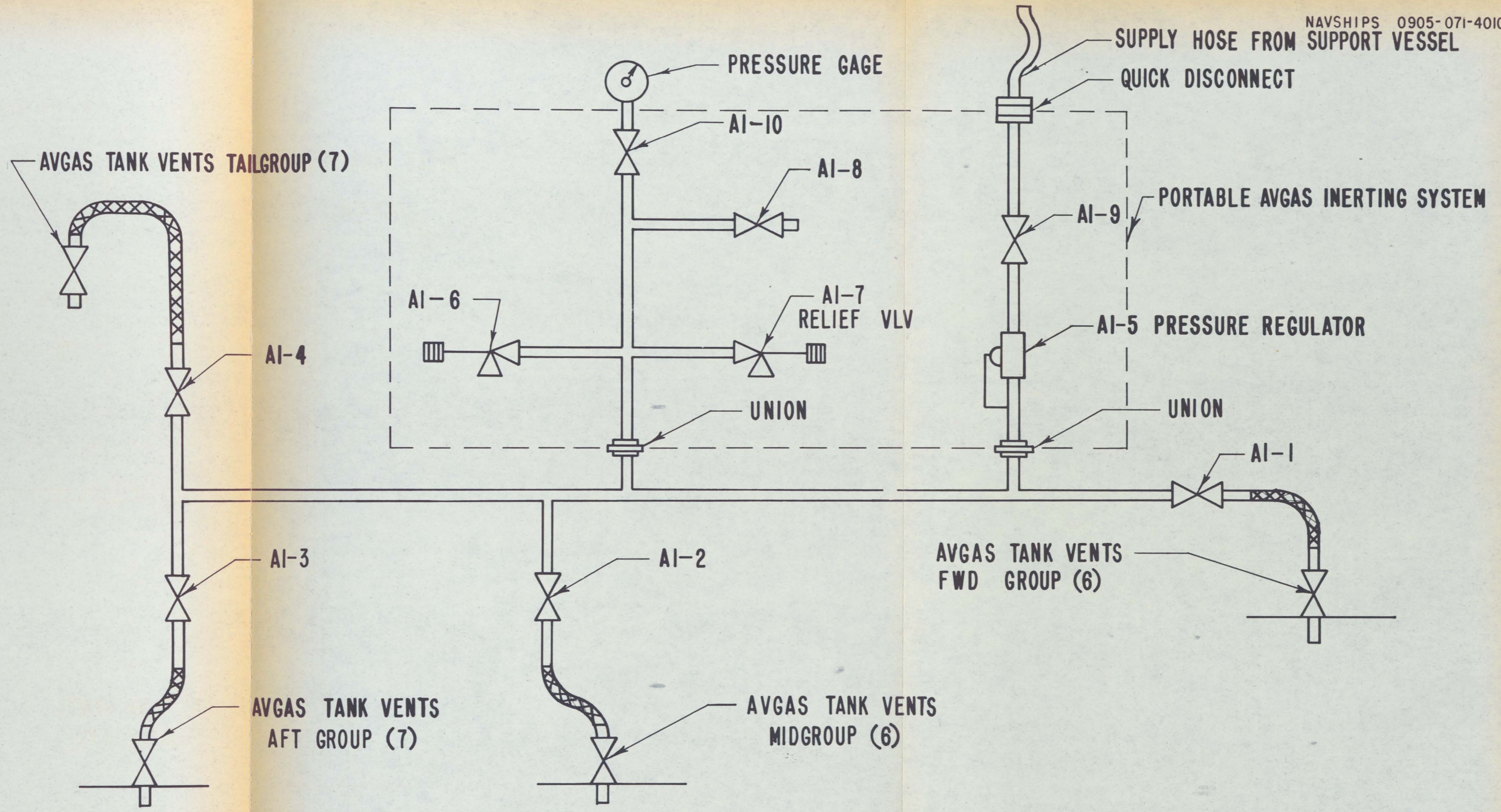

FIGURE 2-6. NITROGEN INERTING SYSTEM

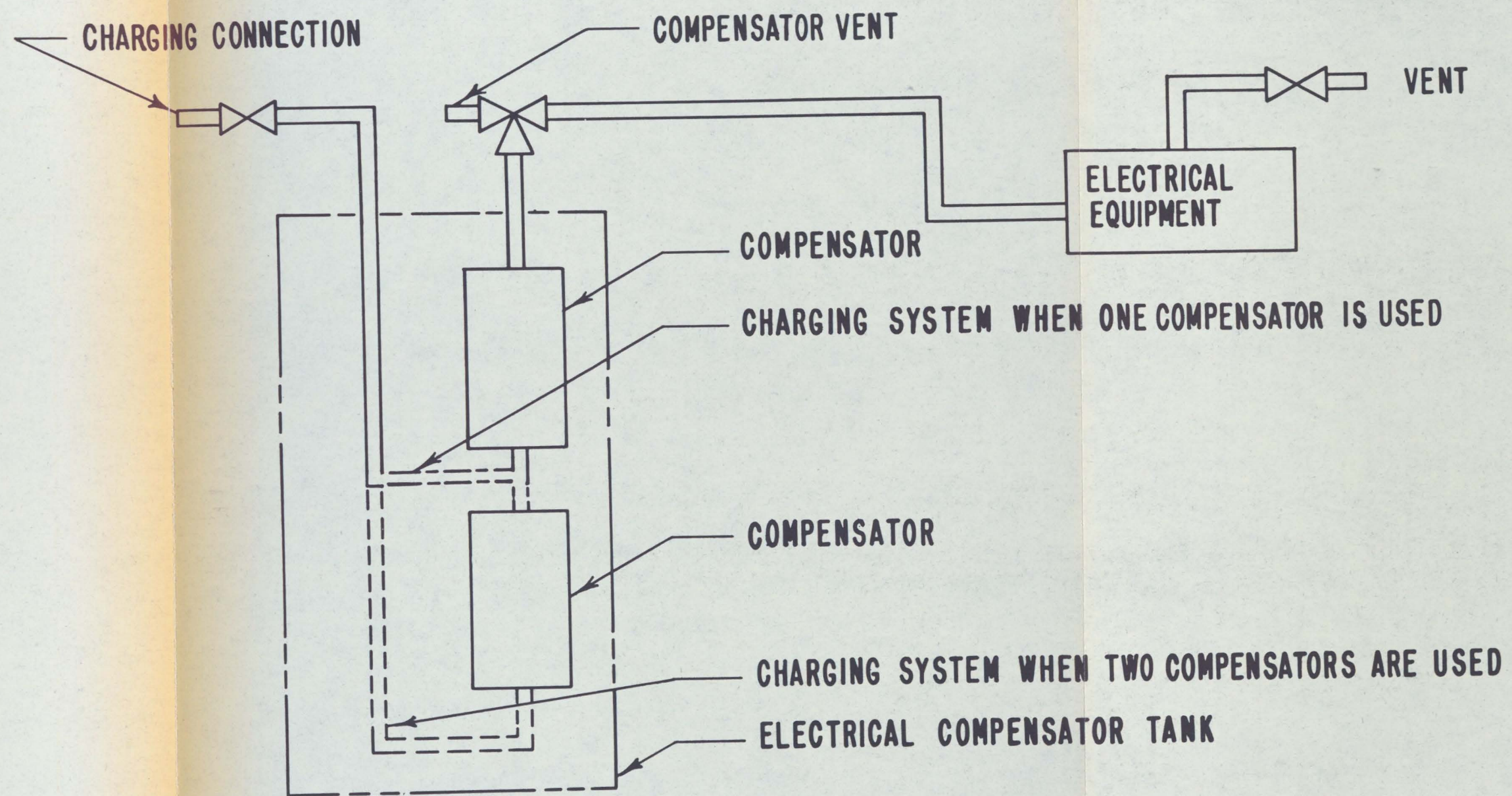

FIGURE 2-7. ELECTRICAL EQUIPMENT COMPENSATION SYSTEM (TYP)

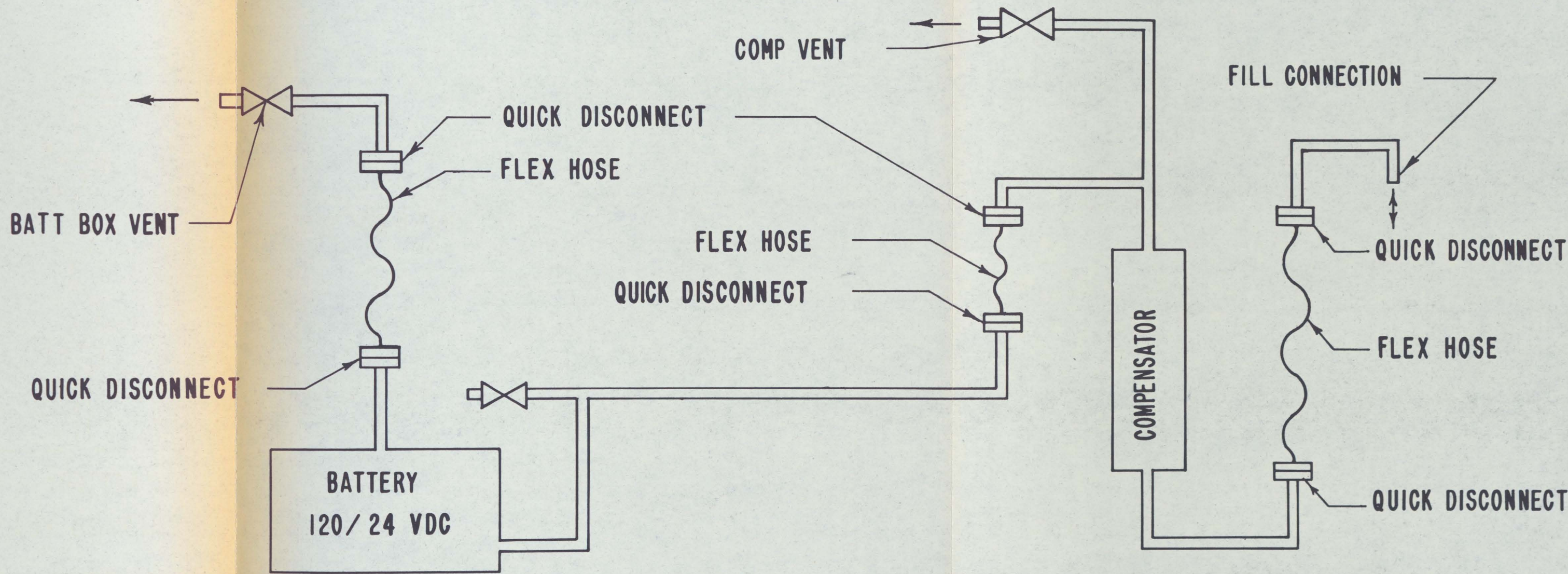

FIGURE 2-8. BATTERY COM-PENSATION SYSTEM

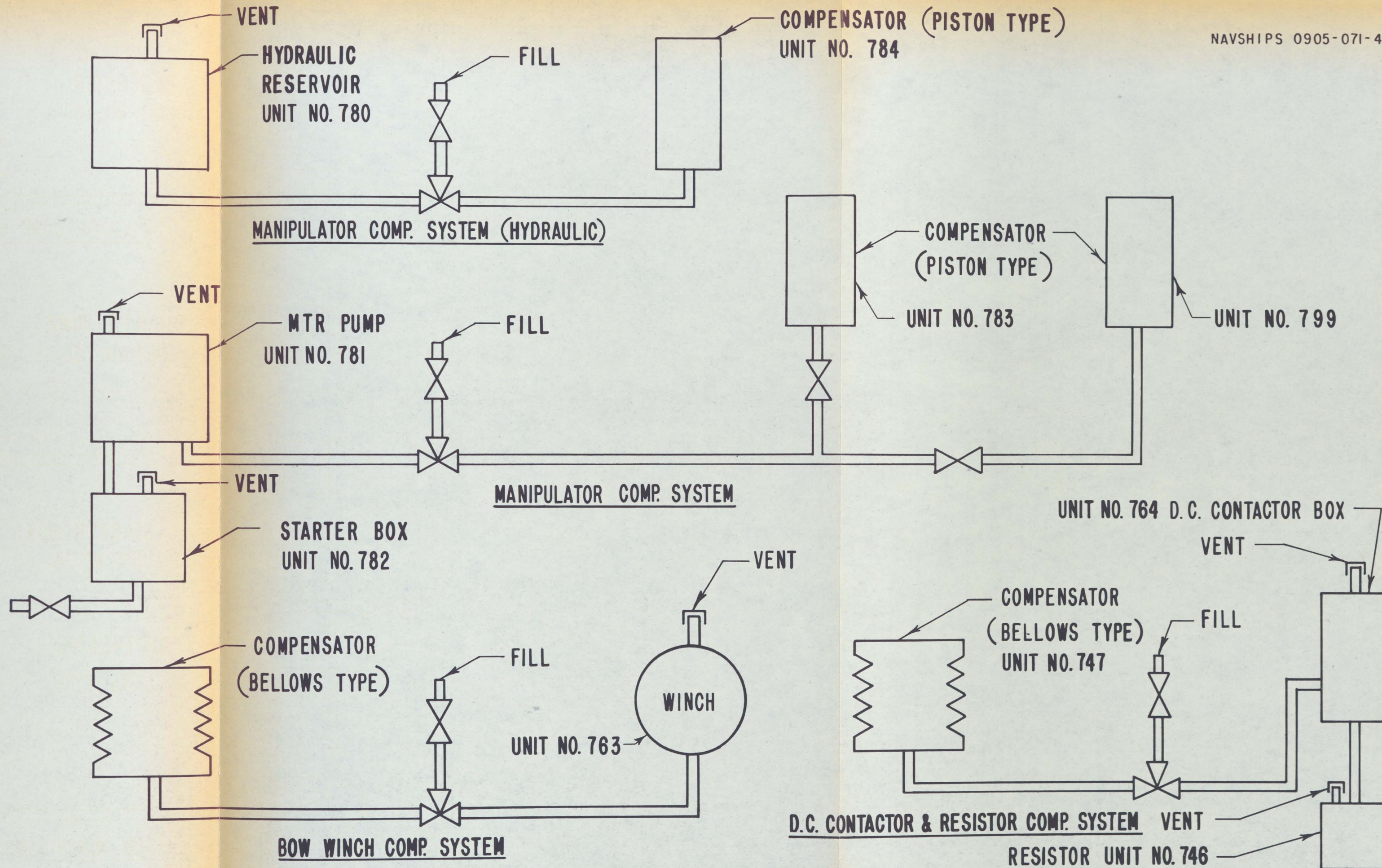
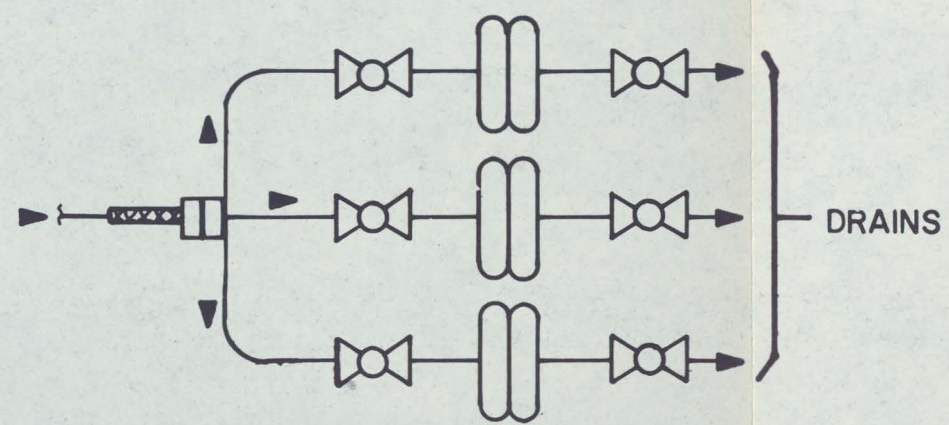
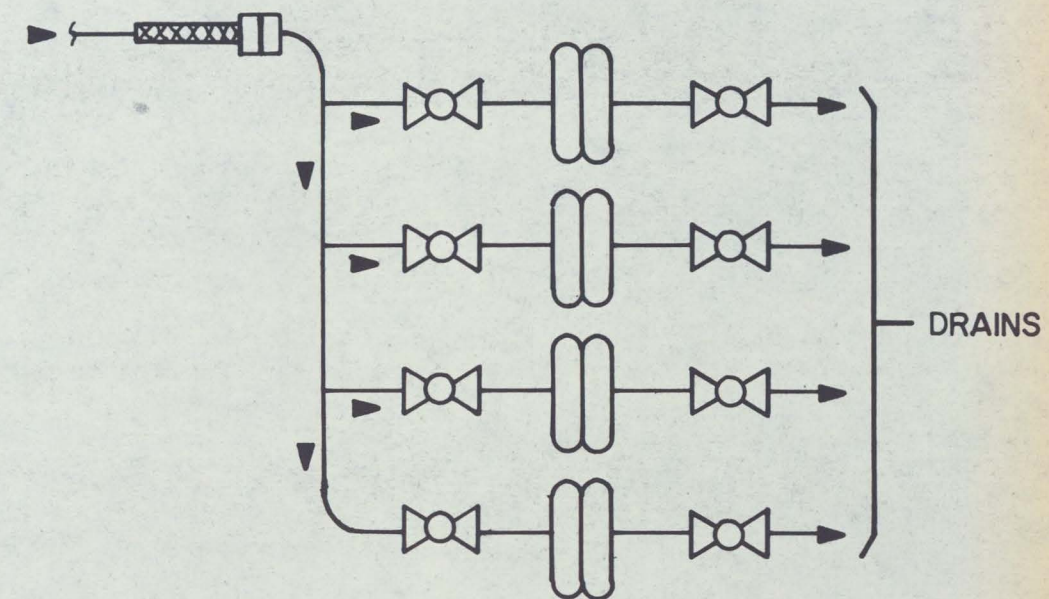

FIGURE 2-9. APPENDAGE COMPENSATION SYSTEM



AFT PIPING ARRANGEMENT



FORWARD PIPING ARRANGEMENT

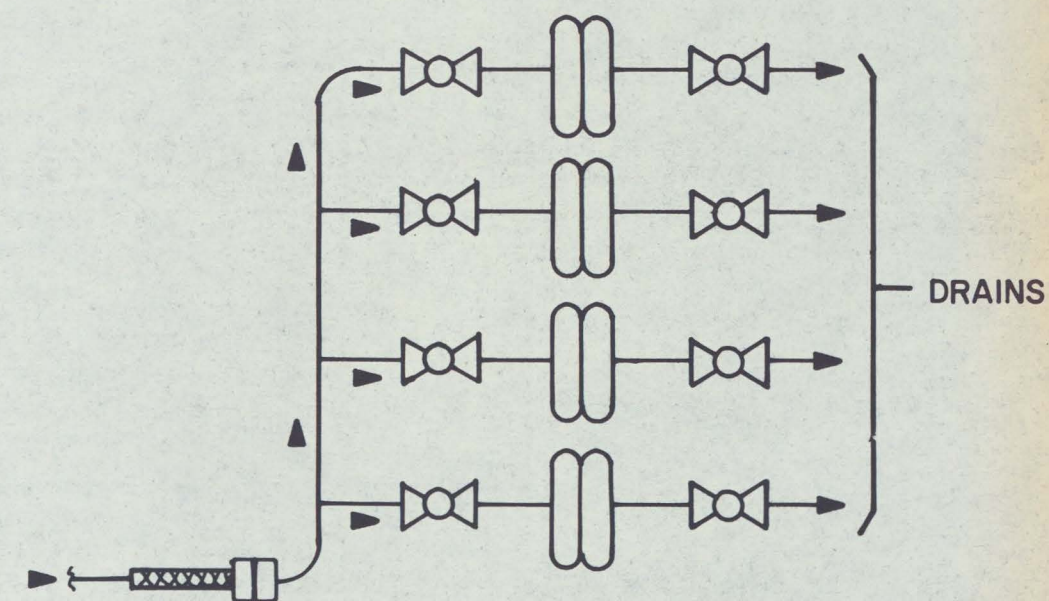
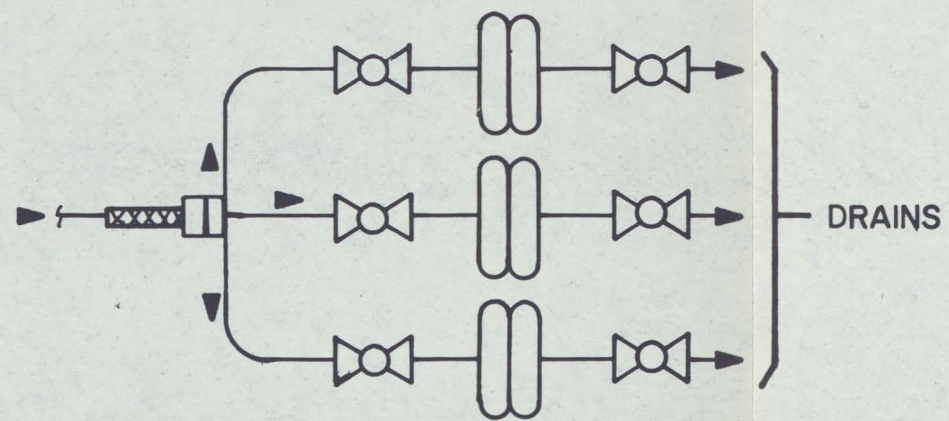

LEGEND



BALL VALVE



QUICK DISCONNECT COUPLING

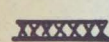

FLEX HOSE (L.P. AIR SUPPLY)

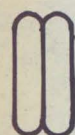

AIR MOUNT

FIGURE 2-10. LANDING GEAR SHOCK MITIGATION SYSTEM



ELECTRICAL

CHAPTER 3

ELECTRICAL SYSTEM

Number		Page
3-1.	Introduction	3-1
3-3.	General System Description	3-1
3-6.	Power Distribution System	3-1
3-61.	Propulsion System	3-13
3-67.	Propulsion Control Panel (Unit 700A10)	3-14
3-77.	Lighting System	3-16
3-104.	Safety Systems	3-24
3-108.	Antechamber Blow System	3-26
3-112.	Buoyancy Control System	3-26

CHAPTER 3

ELECTRICAL SYSTEM

3-1. INTRODUCTION.

3-2. This chapter provides a detailed functional description for each of the five subsystems comprising the Trieste II Electrical System. A list of publications related to the electrical system is included as an appendix to this SIB, and is offered as a source of additional reference material.

3-3. GENERAL SYSTEM DESCRIPTION.

3-4. The electrical system provides all power for the basic operation of the vehicle, including its navigation, lighting and sensor systems. The electrical system consists of the following five subsystems:

1. Power Distribution System - This system distributes power from several on-board batteries through distribution boxes and power panels to all electrical equipment.

2. Propulsion System - This system provides the propulsion necessary for control and movement of the vehicle in the horizontal plane.

3. Buoyancy Control System - The buoyancy control system allows for precise control and movement of the vehicle in the vertical plane.

4. Lighting System - The lighting system serves the dual purpose of providing illumination for internal and external vehicle use, while also providing source illumination for television and still camera operation.

5. Safety System - This system monitors the various operational and life-support systems of the vehicle and provides audible and visual alarms for the operators.

3-5. A detailed functional description for each of the five electrical subsystems is provided in the following paragraphs.

3-6. POWER DISTRIBUTION SYSTEM.

3-7. GENERAL. The power distribution system provides for the distribution and application of all electrical power required for the operation of equipment on the vehicle. The main subsystems comprising the power distribution system consists of the following:

1. 24-VDC External power distribution system
2. 120-VDC Power distribution system
3. 24-VDC Sphere power system
4. AC Power distribution system
5. 24-VDC Essential battery system
6. Computer power
7. CTFM Power
8. 12-VDC Power
9. Battery monitoring system

3-8. 24-VDC EXTERNAL POWER DISTRIBUTION SYSTEM. The 24-VDC external power distribution system (Figure 3-1) provides 24-VDC power for the vehicle and consists of the following units:

1. External 24-volt battery - (Unit 802)
2. 24-volt battery breaker panel - (Unit 803)
3. 24-volt power distribution panel - (Unit 804)
4. 24-volt charging breaker panel - (Unit 805)
5. 24-volt charging jack assembly - (Unit 917)

3-9. External 24-Volt Battery (Unit 802). The external 24-volt battery is located in the forward half of the aft ballast tank. The battery bank is made up of 16 individual silver-zinc, 5000 ampere-hour cells connected in series. All cells are mounted on rubber pads and are separated from each other by a steel "egg crate" frame. This arrangement allows for circulation of compensating oil and increases the heat transfer effect between and surrounding the cells to maintain a uniform temperature. The cells are held in place in the 24-volt battery box with melamine wedges on all four sides. The cells are bus connected in series in the battery box in such a manner that the magnetic field of the battery is at a minimum. A "bubble breaker" is installed in the vent hole of each cell to minimize the potassium hydroxide electrolyte carry-over as the cell evolves hydrogen gas. The cells are equipped with voltage scanner leads which permit the monitoring of individual cell voltages. The scanner leads are fused as protection against accidental shorting by the cell scanner. The cell terminals, bussing, and scanner leads are encapsulated in polyurethane to prevent the possibility of shorts.

3-10. The 24-volt power from the positive terminal of the battery is carried by four 2/0 cables connected in parallel, and the negative 24-volt power is carried by four 2/0 cables connected in parallel from the battery box (Unit 802) to the 24-volt battery breaker panel (Unit 803). A bus disconnect is installed in the battery box to permit opening the + leg of the system. Access to the disconnect is gained through an oval access plate in the battery box cover.

3-11. The battery box is compensated with Marcol 52 oil. A blue dye (butylaminomethylamino anthraquinone) is added to the oil at the ratio of 3.12 grams of dye per 55 gallons of oil to allow visual detection of the oil/electrolyte interface.

3-12. 24-Volt Battery Breaker Panel (Unit 803). The 24-volt battery breaker panel serves as the main circuit protection device for the 24-volt system. The panel is located on the starboard bulkhead in the aft ballast tank above the 120-volt battery. The enclosure has a stainless steel flange with an O-ring groove. The cover is also of stainless steel and has a machined surface where it meets the O-ring. The stuffing tube plate on the bottom is made of stainless steel, containing eight stuffing tubes, and is also provided with an O-ring groove. Six penetrators are affixed to the bottom of the enclosure. A blank cover plate, with a rubber gasket cemented to the back (to protect the machined surface) is provided for installation whenever the stuffing tube plate is removed. The enclosure is compensated with 1-centistoke silicone oil. Teflon blocks have been fitted around the hardware inside the box to reduce the volume of compensating fluid required.

3-13. The main power cables for both the source and the load side of the 24-volt circuit breaker are four positive and four negative 2/0 cables. Source cables come from the 24-volt battery (Unit 802) through stuffing tubes. Load cables go to the 24-volt power distribution panel (Unit 804) through four penetrators. Control cables utilize the remaining two penetrators. The circuit breaker is set for an instantaneous trip at 630 amperes. The circuit breaker closing coil receives power from the 120-VDC power distribution system via a 6/2 control cable. This power source allows the circuit breaker to operate independently from the system it controls.

3-14. The circuit breaker has an 800-amp, 50-mv shunt. Control cables carry the shunt sensing leads to the EXTERNAL 24 VOLT DC AMMETER located on the master power panel (700A33) and the 5000-Ah meter on the ampere-hour panel (700A87). The voltage sensing leads on the load side of the breaker go to the EXTERNAL 24 VOLT DC VOLTMETER which has connected in parallel to it, the power to the converter circuit for the ampere-hour meters and the common terminals of the ground detector/sensing switch. The 24-VDC and 120-VDC battery bus ground detector control and readout is part of general panel (Unit 700A205) located in Bay 5 (Figure 3-21). The two-position ground detector/sensing switch either connects to ground detector pins inside the sphere or to the 24-volt sensing plugs located in the 120-volt charging jack assembly (Unit 918) rack located in the sail.

3-15. The circuit breaker requires 120-volt power to actuate the closing coil. This is accomplished by closing an auxiliary contactor with 24-volt power, which in turn closes the 120-volt closing coil circuit. As soon as the circuit breaker closes, an antipump coil (Y coil) activates to break the auxiliary coil circuit and keep it open as long as power is supplied to the Y coil. If the breakers close on a fault, then the breaker will immediately open and not close again until power to the auxiliary contactors is interrupted and then reapplied. The 16/10 control cable carries control power for the auxiliary contactor coil and the circuit breaker trip coil. This power is supplied from the 24-VDC essential battery (Unit 700A67) located in the sphere. These control wires parallel other control wires which are spliced in at pothead 3 and then terminate in a plug located in the 24-volt charging jack assembly (Unit 917) to permit control of the breaker from the charging facility (Chapter 7).

3-16. 24-Volt Power Distribution Panel (Unit 804). The 24-volt distribution panel is the main terminal box for the external 24-volt system. It is located on the starboard side, under the superstructure about midship. 24-volt power is supplied to this panel from the 24-volt battery breaker (Unit 803) and then to the various vehicle equipment using 24 VDC.

3-17. The Panel is a stainless steel (CRES) enclosure, similar to the 24-volt battery breaker panel (Unit 803) but without the removable stuffing tube plate. Entry to the unit is via penetrators located on the side of the panel rather than the bottom as on the circuit breaker panel.

3-18. Power is supplied to the distribution panel via four positive and four negative 2/0 cables from the battery breaker panel (Unit 803). These cables are terminated at the two main bus bars on the panel along with four positive and four negative 2/0 cables from the 24-volt charging breaker panel (Unit 805). The power from the main bus bars is fed to terminal boards and then through fuses to the equipment. Ten No. 6 cables carry power from the terminal boards to the sphere penetrators, five positive cables to penetrator No. 1 and five negative cables to penetrator No. 2. Power interruption for the sphere is provided by 200-amp fuses in series with a contactor/overload relay set to open at 300 amperes. The contactor is closed remotely via a separate circuit from the Master Power Panel (700A33). 24-VDC power from the distribution panel is provided to the following equipment:

1. Multiplex bottles-(Units 900, 901, 902, 903)
2. 60 Hz Inverters-(Units 703, 712, 924, 931)
3. DC contactor box-(Unit 764)
4. Lighting contactor bottles No. 1 and No. 2-(Units 713 and 714)
5. Beacon release relay bottle-(Unit 906)

3-19. 24-Volt Charging Breaker Panel (Unit 805). The 24-volt charging breaker panel is a stainless steel enclosure containing the charging circuit breaker. It is located just aft of the 24-volt distribution panel (Unit 804). Two positive and two negative 4/0 cables carry the charging current from the charging power plugs in the 24-volt charging jack assembly (Unit 917) in the sail, to the charging breaker panel. Four positive 2/0 cables in parallel and four negative 2/0 cables in parallel carry the charging current from the 24-volt charging circuit breaker (in the charging panel) to the 24-volt power distribution panel bus bars. The control cable for the 24-volt battery charging circuit breaker terminates at the 24-volt charging jack assembly (Unit 917) in the sail and runs to the closing coil and undervoltage coil in the Charging Breaker Panel.

3-20. The charging circuit breaker closing coil is remotely operated from the charging station. The closing coil and the undervoltage coil control circuit is energized by 120-VDC power. A 50-ohm resistor is placed across the closing coil to help discharge the energy stored in the magnetic field when the contacts are opened. The purpose of the undervoltage coil is to open the circuit breaker if the tender charging and control cables are parted during the charge. This prevents the battery from a possible discharge by a short circuit through seawater.

3-21. 24-Volt Charging Jack Assembly (Unit 917). The 24-volt charging jack assembly is located on the starboard side of the sail. The panel contains six receptacles to accommodate: two 24-volt positive charging cables, two 24-volt negative charging cables, the 24-volt charging circuit breaker remote control cable and the 24-volt battery circuit breaker remote control cable. The receptacles are colored-coded and keyed to correspond with the mating connectors on the 24-volt charging cables.

3-22. Sphere Power Penetrators. All Sphere Penetrators are located at the rear of the sphere, under the main wire well just aft of the access trunk. The power penetrators, Units 1000A1 and 1000A2, are the connector assemblies that penetrate the sphere to provide the main sphere power. The No. 6 power conductors supply the pins of the female side of the penetrator assembly from the 24-volt power distribution panel (Unit 804). The male side of the assembly is connected to teflon coated EE-8 wires which terminate at circuit breakers, Units 700A75 and 700A76 in Bay 9 of the sphere.

3-23. 120-VDC POWER DISTRIBUTION SYSTEM. The 120-VDC power distribution system (Figure 3-2) provides power to the propulsion motors, the winch motors, manipulator arm and part of the lighting system. The basic components of the system are outlined below and discussed in detail in the following paragraphs:

1. 120-volt battery - (Unit 808)
2. 120-volt battery breaker panel - (Unit 809)
3. 120-volt distribution panel - (Unit 810)

4. 120-volt charging breaker panel - (Unit 811)

5. 120-volt charging jack assembly - (Unit 918)

3-24. 120-Volt Battery (Unit 808). The 120-volt battery is located in the after half of the aft ballast tank. The battery bank consists of 80 individual silver-zinc cells (952 ampere hour) arranged in a 9 by 9 configuration, with the space of one cell reserved for the battery monitoring scanner switch. All cells are mounted on rubber pads and are separated from each other by a steel "egg crate" frame which allows the compensating oil to circulate between the cells to maintain a uniform temperature. The cells are wedged in place in the battery box with 1/8-inch thick polyethylene sheets as required. The cells are bus connected in series and arranged to minimize the magnetic field effect of the battery. A "bubble breaker" is installed in the vent hole of each cell to minimize the potassium hydroxide electrolyte carryover. The 120-volt battery bank is also equipped with voltage scanner leads (paragraph 3-9) which are fused inside the battery box as protection against accidental shorting by the cell scanner. The battery terminals, bussing and scanner leads are encapsulated in polyurethane to prevent grounds.

3-25. The battery box has four access plates, three of which contain stuffing tubes. The fourth access plate is used to open two battery disconnects which separate the battery bank into three sets of cells of 40 volts. The 120-volt battery is compensated with the same oil as the 24-volt battery, Marcol 52 oil.

3-26. The 120-VDC power from the positive terminal of the battery is carried by three 2/0 cables connected in parallel and the 120-VDC return is carried by three 2/0 cables connected in parallel to the negative terminal of the battery.

3-27. 120-Volt Battery Breaker Panel (Unit 809). The 120-volt battery breaker serves as the primary circuit protection device for the 120-volt system. The panel is located on the port bulkhead in the after ballast tank above the 120-volt battery box. The enclosure is similar in construction to the 24-volt battery breaker panel (paragraph 3-12). The 120-volt panel receives 120-VDC power from the 120-volt battery (Unit 806) via six 2/0 cables (3 positive cables in parallel and 3 negative cables in parallel). On the load side of the breaker, the power is supplied to the 120-volt distribution panel (Unit 810) via the same cabling arrangement.

3-28. A No. 6 AWG, two conductor control cable, supplies a 120-VDC power to the 24-volt battery breaker (Unit 802) closing coil. The MWF-10 control cable permits remote control of the circuit breaker via the 120-volt charging jack assembly (Unit 918). The control cable also contains sensing circuits for the master power panel (700A33), and voltage sensing circuits for the external 120-VDC voltmeter. The current sensing circuit from the 300-amp, 50-mv shunt is carried to the external 120-VDC ammeter and to the 952 Ah meter on the ampere-hour meter panel (700A87).

3-29. The circuit breaker requires 120 VDC to actuate the closing coil. The closing coil is actuated by an auxiliary contactor which is closed with 24 VDC provided by the essential battery. This in turn closes the 120-volt closing coil circuit. When the breaker is closed, an antipump coil (Y coil) is activated which opens the auxiliary coil circuit and keeps it open as long as power is applied. In case of a fault, the breaker will open and cannot be reclosed until the power to the auxiliary contactor coil is interrupted and reapplied. The circuit breaker is set for an instantaneous trip at 725 amperes.

3-30. 120-Volt Distribution Panel (Unit 810). The 120-volt distribution panel provides 120-volt power to motor controllers and other vehicle equipment outlined below. The panel is located just aft of the sail on the starboard side under the super-structure. The panel enclosure is similar in construction to the 24-volt battery breaker panel (paragraph 3-12) except for overall size and the layout of the penetrators.

3-31. The distribution panel receives power from the 120-volt battery breaker panel via three 2/0 cables on the positive leg and three 2/0 cables for the negative (or return) leg. These cables are terminated at the two main bus bars on the panel. Two 2/0 cables from the 120-volt charging breaker panel (Unit 811) are also connected to the main bus bars. One cable is connected to the positive bus and the other to the negative bus. A sensing circuit from the 500-amp, 50-mv shunt in the positive bus is carried to the sphere to monitor the propulsion motor current.

3-32. The following vehicle equipment receives power from the 120-Volt Distribution Panel (Unit 810):

1. DC Contactor box-(Unit 764)
2. Starter box-(Unit 782)
3. Pre-regulator No. 1-(Unit 704)
4. Stbd motor controller-(Unit 830)
5. Port motor controller-(Unit 828)
6. Centerline motor controller-(Unit 826)
7. Bow thruster motor controller-(Unit 824)
8. Ball winch controller-(Unit 766)

3-33. 120-Volt Charging Breaker Panel (Unit 811). The 120-volt charging breaker panel is located midship on the port side under the super-structure. The enclosure is similar in construction to the 24-volt battery breaker panel (paragraph 3-12) except for overall size and the layout of the penetrators.

3-34. Two 2/0 cables (one positive, one negative) from the 120-volt charging breaker panel are routed to the 120-volt distribution panel (Unit 810) and are used to carry charging current during the battery charging operation. Two additional 2/0 cables, (one positive, one negative) carry the charging current from the 120-volt charging jack assembly (Unit 918) to the 120-volt charging breaker panel. The power for actuating the closing and undervoltage coils of the charging circuit is carried from the charging jack assembly to the charging breaker panel by a control cable. Several other control cables are also used with the battery monitoring system.

3-35. The charging circuit breaker is remotely operated from the tender. The closing coil and undervoltage coil are operated with 120-VDC power. The undervoltage coil causes the circuit breaker to open automatically if the charging and control cables from the tender part during charge. This prevents the battery from a possible discharge by short circuit through seawater.

3-36. The output from the 24-VDC and 120-VDC battery sensing circuits, and the 24-VDC power application for the scanner switch motor can be transferred from the sphere to the support ship monitoring system. The transfer is accomplished remotely from the support ship via cabling to three 120-VDC relays in the charging breaker panel (Unit 811).

3-37. 120-Volt Charging Jack Assembly (Unit 918). The 120-volt charging jack assembly is located on the port side of the sail. The panel assembly contains six receptacles to accommodate: 1) a 120-volt positive charging cable; 2) a 120-volt negative charging cable; 3) a 120-volt charging circuit breaker remote control circuit; 4) a 120-volt battery circuit breaker remote control circuit; 5) the 24-volt battery/120-volt battery monitoring circuits; and 6) the monitor/ground detector sensing circuits. The receptacles are color-coded and keyed to correspond with the mating connectors on the 120-volt charging cables.

3-38. 24-VDC SPHERE POWER DISTRIBUTION SYSTEM. The 24-VDC sphere power distribution system (Figure 3-3) provides 24-VDC power to equipment inside the sphere. The Distribution System consists of:

1. Master power panel - (Unit 700A33)
2. Port power panel - (Unit 700A34)
3. Starboard power panel-(Unit 700A27)
4. Internal 24-volt breaker assemblies - (Units 700A75 and 700A76)

5. Internal wiring panels Nos. 35 and 84 - (Units 700A212 and 700A213)
6. Ampere hour meter - (Unit 700A87)
7. Power relay panel - (Unit 700A86)
8. Central ground point cable - (Unit 700E01)

3-39. Internal 24-Volt Breaker Assemblies (Units 700A75 and 700A76). The 24-volt power passes through the breaker assemblies after entering the sphere. The breakers serve as the primary sphere circuit interrupting devices and are rated at 225 amperes. Breaker assembly 700A75 is the negative 24-volt (return) breaker assembly and Unit 700A76 is the positive 24-volt breaker assembly. If the breakers are tripped, all 24-volt power to the sphere is interrupted, the voltage and amperage reading on the sphere power meters (master power panel - Unit 700A33) is zero, and the signal to the power relay panel (Unit 700A86) is interrupted, de-energizing the relay. The de-energized relay opens the sphere power contactor, cutting the power to the sphere from the outside. The power relay can be re-energized by operating the tripped breaker and placing the sphere 24-VDC power switch (master power panel - Unit 700A33) momentarily to the CLOSE position.

3-40. Master Power Panel (Unit 700A33). The master power panel (Figure 3-4) which is located in Bay 7 of the sphere, is the main control for all power on the vehicle. The circuit breakers for both the 24-volt and the 120-volt batteries can be operated from this panel. The panel receives 24-VDC sphere power from the breaker assemblies (Unit 700A75/A76) and then distributes this power from positive and negative busses through circuit breakers. The essential loads bus is located in the master power panel and is supplied from the essential battery (Unit 700A67) if sphere power is lost. The master power panel distributes power through circuit breakers to the equipment shown on Figure 3-3. If sphere power is lost, then the essential battery supplies power to the equipment on the essential loads bus. This equipment is discussed separately in other sections of this chapter and chapter 4.

3-41. Port Power Panel (Unit 700A34). The port power panel (Figure 3-5) which is located in Bay 4, controls the power distributed to the vehicle equipment as shown on Figure 3-3. The panel allows the operator to control power to this equipment with circuit breakers and also to determine the current drawn by the equipment.

3-42. Starboard Power Panel (Unit 700A27). The starboard power panel (Figure 3-6) which is located in Bay 1, controls the power distributed to the vehicle equipment as shown on Figure 3-3. The starboard panel provides circuit breaker control for the equipment, and incorporates the same current monitoring capabilities as the port power panel discussed in paragraph 3-41.

3-43. Internal Wiring Panels (Units 700A212 and 700A213). The internal wiring panels are enclosures providing for junction and interconnection of cables from one unit to another. The cables feed into the panels through connectors, are tied to terminal boards, and then fed out through connectors to their respective units. Internal wiring panel A212, which is located in back of Bay 7 provides routing for power source cables to and from the power panels or to the computer. This panel also serves as the termination point for spares from the penetrators.

3-44. Internal wiring panel A213 which is located in the back of Bay 1, routes the cables for AC power to the internal equipment and also terminates spares to the penetrators.

3-45. Ampere-Hour Meter Panel (Unit 700A87). The ampere-hour (Ah) meter panel, which is located in Bay 9, monitors the power drawn from the main 24- and 120-volt batteries. The panel displays the power readings for both batteries and, in addition, provides alarm signals to the master alarm panel. The alarm signals are used to actuate the low-charge and the low-cell alarms. The low-cell sensing signal is derived from the low-rate detector (battery scanner). The Ah-meter panel contains two ampere-hour meters, one each for the 24- and the 120-volt batteries, and two reset switches for calibration of the displays. Also located on the panel are a POWER ON switch and an ALARM ON/CLEAR switch.

3-46. Central Ground Point Cable (Unit 700E01). The central ground point cable provides the central ground bus for all electrical equipment within the sphere and serves to eliminate isolated grounds. The cable is located around the top ring of the sphere and is connected to terminal boards in each of the bays. The grounds from the individual equipment are connected to the terminal boards and through the ground ring to the central ground point which is located at the dog of the hatch, and from the hatch to the vehicle.

3-47. AC POWER DISTRIBUTION SYSTEM. The alternating current required for the operation of vehicle equipment is provided from 24-VDC power, which is converted to 115-VAC (60- or 400-Hz) power by the use of inverters. The vehicle is equipped with four external 60-Hz inverters, two internal 60-Hz inverters, and two internal 400-Hz inverters.

3-48. External AC Power Distribution. The external 115-V, 60-Hz AC power (Figure 3-7) is provided by two 2-kW inverters, No. 7 (Unit 924) and No. 8 (Unit 931), and two 500-VA inverters, No. 5 (Unit 703) and No. 6 (Unit 712). Units 924 and 931 provide AC power to the multivapor ballasts Nos. 1, 2, 3 and 4 for the external lighting system. Unit 712 provides AC power to the pan and tilt mechanisms (Units 709, 727, 728 and 729) via the multiplex bottles. Unit 703 provides AC power to the sphere via penetrator 11 (1000A11) where it serves as backup power to the AC power panel (700A69, Figure 3-8) in case of failure of the internal 115V, 60-Hz power system.

3-49. Internal AC Power Distribution. The internal 115-VAC power (Figure 3-9) is provided by two 500-VA, 60-Hz inverters, No. 1 (Unit A05) and No. 2 (Unit A20), and two 250-VA, 400-Hz inverters, No. 3 (Unit A12) and No. 4

(Unit A41), that are located inside the sphere. The 24-VDC power to the 400-Hz inverters is provided through two circuit breakers located on the port power panel (700A34). The 60-Hz inverters are powered via two circuit breakers on the starboard power panel (700A27).

3-50. The four internal inverters and external inverter No. 5 provide power to the AC power panel (700A69), where the power is then distributed to the equipment. The normal AC power distribution is shown below, however, the 60-Hz and 400-Hz load transfer switches located in the AC power panel permit the loads of inverters No. 1 and No. 2 to be transferred to a single inverter, and the loads of inverters No. 3 and No. 4 to be transferred to a single inverter. In addition, the 60-Hz equipment powered by inverters No. 1 and No. 2 may be transferred to external inverter No. 5 (Unit 703).

3-51. Normal AC Power Distribution. The normal internal AC power distribution is as shown below. Load transfer switches, described in paragraph 3-50, permit the transfer of loads between inverters of similar frequency.

1. 115 Volt, 60 Hz.

a. INVERTER NO. 1 (700A05).

Analog plotter panel (700A16)

Sound velocimeter (700A102)

Utility outlet (700A96)

Video tape recorder (700A103)

b. INVERTER NO. 2 (700A20).

CTFM sonar (700A18)

Low voltage detector (700A26)

2. 115 Volt, 400 Hz.

a. INVERTER NO. 3 (700A12).

Computer control panel (700A11)

Gyro repeater and indicator (700A07)

b. INVERTER NO. 4 (700A41).

Directional Gyro (700A07)

Propulsion control panel (700A10)

3-52. 24-VDC ESSENTIAL BATTERY POWER SYSTEM. The 24-VDC essential battery power system (Figure 3-3) is supplied by the essential battery (Unit 700A67). The battery consists of (16) 200 ampere-hour silver-zinc cells (LR-200) located inside the sphere in Bay 4. Power is supplied by the battery through

an automatic load transfer relay or an emergency relay bypass switch in the master power panel (Unit 700A33). The 24-volt battery power is also used for control of the 24-volt and 120-volt circuit breakers (Units 803 and 809, respectively).

3-53. The essential battery supplies power to the essential battery automatic transfer switch contacts, which close upon loss or interruption of power from the main sphere power bus in the master power panel. These contacts activate a motor-driven switch and the essential battery alarm, which are both powered by the essential battery. Contacts driven by the motor-powered switch interrupt the sphere power and close the essential battery supply to the essential bus. The contacts also illuminate an amber light on the master power panel, signalling that the essential battery is supplying power to the essential load bus. In an emergency, the motor-powered switch may be bypassed with the essential battery relay bypass switch.

3-54. COMPUTER POWER SUPPLY. The navigation computer (700A30) power supply provides a constant, filtered source of 24-VDC power. The port power panel (700A34) supplies the computer power supply (700A31) with 24 VDC. The computer power supply is a DC-DC converter, which serves to eliminate voltage variations due to battery voltage changes. The converter also eliminates any AC signals which are imposed on the DC power distribution system by the inverters.

3-55. CTFM SONAR POWER SUPPLY. The continuous-transmission frequency-modulated (CTFM) sonar system is provided with two power inputs, 28-VDC and 115-V, 60-Hz. The CTFM sonar analyzer panel (700A18) receives the 115-V, 60-Hz power from the AC power panel (700A69). The 28-VDC power is obtained from the CTFM sonar power supply (700A19). The CTFM sonar power supply is a DC-DC converter which receives 24 VDC from the starboard power panel (700A27) and delivers constant, filtered 28-VDC power to the CTFM sonar analyzer panel.

3-56. INTERNAL 12-VDC POWER SYSTEM. The internal 12-VDC power system consists of seven internal batteries that power the emergency release magnets and shot valves. Five batteries are connected to the release magnets and two to the shot valves. Provisions have been made for installation of two more batteries in the event that the bow device and/or centerline device release magnets are installed for mission use. Each battery contains eight 100 ampere-hour silver cells which supply power to the holding magnets through the ballast control panel. The emergency release magnets (tripping levers) are discussed in chapter 6, paragraph 6-37.

3-57. BATTERY MONITORING SYSTEM. The battery monitoring system consists of three major components, the scanner, the high-rate detector and the low-voltage detector. The scanner is a motor-driven selector-switch installed within the 120-VDC battery box (Unit 808) and serves both the 24- and 120-volt batteries (Units 802 and 808). The selector-switch sequentially scans all 96 cells in less than 5 minutes. The high-rate detector is normally carried aboard the support ship. During a battery charge, the high-rate detector provides power to the scanner, identifies each cell as it displays its voltage and provides both a visual and audio alarm if an individual cell voltage varies from preset limits. The low-voltage detector mounted within the

sphere, actuates an alarm when any cell reaches the low-voltage cutoff and identifies the battery containing the low voltage cell. The monitored voltage measurements are made at the intercell connectors.

3-58. The scanner switch consists of a mechanically driven, 96-position selector switch and 96-position voltage divider. The scanner sequentially selects individual cells of the battery and feeds their monitored voltages into either the high- or low-voltage detector. The voltage divider function of the switch is excited with a reference voltage, which produces an output voltage numerically equal to the position number of the cell being scanned at any given time. This numerical output voltage, along with the monitored voltage level, are fed to digital readout displays.

3-59. The high-rate detector, in conjunction with the scanner switch assembly in the 120-VDC battery box, monitors individual cell voltages of both vehicle battery systems during charging operations. The scanner sequentially selects individual cells and feeds the monitored voltage into the high-rate detector, where it is compared against a preset reference voltage. When the reference voltage is exceeded by any monitored cell voltage, an alarm light and external alarm are activated and the system will cease to scan until manually reset. In addition, the cell voltage and cell number (position) are continuously displayed on digital readout meters.

3-60. The low-voltage detector (700A26) monitors the individual cell voltages during a mission. The scanner switch sequentially selects an individual cell and feeds the monitored voltage into the low-voltage detector, where it is then compared against a preset reference voltage. When the cell voltage falls below the reference voltage, an alarm light and external alarm are activated and the system ceases to scan until manually reset. (See Figure 4-23.)

3-61. PROPULSION SYSTEM.

3-62. GENERAL: The propulsion system (Figure 3-10) consists of four thruster motors (bow, centerline, port and starboard) their associated motor controllers and the propulsion control panel. The motors and controllers are all external to the sphere and the propulsion control panel is located in Bay 2 within the sphere. The propulsion system provides the vehicle with adequate maneuverability for search and recovery operations. Chapter 6, paragraph 6-52 provides additional information on the function and steering capabilities of each of the four thruster motors.

3-63. THRUSTER MOTORS (Units 823, 825, 827, 829). The four thruster motors are located as follows: the centerline thruster (Unit 825) on the centerline in the after part of vehicle; the port thruster (Unit 827) and starboard thruster (Unit 829) on the wings, in the after part of the vehicle; and the bow thruster (Unit 823) is topside and starboard on the forward part of the vehicle. The port, starboard and centerline thrusters provide thrust ahead and astern, while the bow thruster provides port and starboard thrust.

3-64. All thruster motors are rated at 6.5 horsepower, a 1750 rpm and powered by 120 VDC. The 120 VDC is supplied from the 120-volt distribution panel (Unit 810) through the motor controllers to the armature and field windings of the motors. The port, starboard, and bow thrusters are integral motor-gear units that are identical and interchangeable. They attain a shaft speed of 194 rpm @ 120 VDC. The centerline thruster is an integral motor-gear unit that attains a shaft speed of 110 rpm @ 120 VDC. The motors are compensated for deep submergence operation with a mixture of 95-percent silicon oil and 5-percent dioctyltetrachlorophthalate.

3-65. MOTOR CONTROLLERS (Units 824, 826, 828, 830). The motor controllers are located externally, topside of the vehicle, beneath the superstructure as follows: the centerline motor controller (Unit 826), port outboard between frames 14 and 15; the bow motor controller (Unit 824), port outboard between frames 17 and 18; the port motor controller (Unit 828), port outboard, frame 20; and the starboard motor controller (Unit 830), starboard, outboard, frame 20.

3-66. The motor controllers for all four thrusters are identical and are contained in a silicon oil compensated enclosure. Each controller receives 24-VDC power from the master power panel (Unit 700A33), and 24-VDC control power from the propulsion control panel (Unit 700A10) from within the sphere, and 120-VDC power from 120-VDC distribution panel (Unit 810) external to the sphere. Each motor controller circuitry includes three contactors and three resistors for sequencing the motor up to speed in three steps. The circuit also includes two contactors for reversing the armature circuit to provide forward/reverse motor operation and a magnetic overload for detecting high armature currents. A selenium rectifier and a rheostat are also provided in each controller circuit to dissipate stored energy in the field windings when power to the field is interrupted, and for adjusting the shaft speed of the motor, respectively.

3-67. PROPULSION CONTROL PANEL (Unit 700A10).

3-68. GENERAL. The propulsion control panel (Figure 3-11) consists of two sections. The main section or fixed propulsion control panel, is mounted in Bay 2 inside the sphere. The other section or portable propulsion control panel, is connected by a retractable cable, and nests inside the fixed propulsion control panel.

3-69. Power Distribution. The propulsion control panel receives 24-VDC control power for mode selection and indicating lights from the propulsion panel circuit breaker on the master power panel (Unit 700A33); 24-VDC control power for propulsion control and status indication of the port, starboard, bow, and centerline thruster motors from the port, starboard, bow and centerline circuit breakers, respectively, on the master power panel; 24 VDC for computer interfacing from the computer sequence circuit breaker on the master power panel; and 115V, 400 Hz for syncros and reference from the propulsion control panel circuit breaker on the AC power panel (Unit 700A69). The return for each thruster motor control circuit is routed

through a set of overload contacts in the thruster's motor controller, so that in the event of an overload, the control and indication circuitry of the thruster motor will be disconnected and reset to the OFF position.

3-70. Propulsion Control Panel (Fixed) Controls and Indicators. Controls and indicators on the fixed section of the propulsion control panel (Figure 3-11) consists of:

1. A meter for readout of current to the propulsion thruster motors, which is sensed from a shunt in the 120-volt distribution panel.
2. A digital display readout for indication of the gyro heading received from the gyro repeater indicator (Unit 700A07).
3. An OFF-LOW-HI switch for control of synchro indicator and propulsion current meter illumination.
4. A set of VERTICAL TRAIN controls (for future use, when trainable thruster motors are installed on the vehicle).
5. A set of mode switch-indicators for selection of the MANUAL, HAND CONTROLLER, AUTO, or EMERGENCY STOP modes. The EXECUTE and AUTO STOP switch-indicators are used in conjunction with the AUTO mode.
6. A set of STATUS switch-indicators for controlling and indicating the operation of all four thruster motors.

3-71. Propulsion Control Panel (Portable Section) Controls and Indicators. Controls and indicators on the portable section of the propulsion control panel (Figure 3-11) consists of:

1. An EMERGENCY STOP switch and indicator for selection of the emergency stop mode of operation.
2. A two-axis switch for control of the bow and centerline thruster motors.
3. Two eight-position thruster training motor controls (for future use when trainable thruster motors are installed on the vehicle).
4. Two variable speed switches for selecting the NORM (forward) or REVERSE direction of the port and starboard thruster motors. The variable speed portion of the controllers is for future use when variable speed thruster motor controllers are installed on the vehicle.
5. Two synchro indicators (for future use to indicate the position of the trainable thruster motors).

3-72. Propulsion Control Panel Operations. Operation in the manual mode is achieved by depressing the appropriate status switch-indicator for the

desired thruster motor operation. In the auto mode, the bow and centerline motors are under control of the navigation computer.

3-73. Hand-Control Mode (Portable Section). Operation in the hand-control mode is achieved by selecting the desired thruster motor operation, using the two-axis switch (FWD, STBD, REV, PORT) and the two variable speed switches (NORM, OFF, REV) on the portable section of the propulsion control panel. A sensing circuit is used to prevent operation of the bow and centerline or port and starboard thrusters, should the two-axis switch or one of the variable speed switches be in an energized position on entering the hand control mode. The portable section allows the operator to remove the panel at near-bottom conditions to provide precise maneuvering of the vehicle under visual control.

3-74. Auto Mode (Fixed Section). The auto mode section of the fixed panel is used when the bow and centerline thruster motors are under control of the navigation computer (Unit 700A30), and the port and starboard thruster motors are to be controlled by their status switch indicators. The EXECUTE switch indicator is for use in executing a program in the computer. The AUTOSTOP switch-indicator is for stopping an operation executed by the computer.

3-75. Emergency Stop Mode. The emergency stop mode is used to place the centerline thruster motor in the reverse direction, the bow thruster motor OFF, and the port and starboard thruster motors operational from the fixed section of the panel. The emergency stop mode is entered by depressing either of the emergency stop switch (fixed or portable sections). The same switch must be depressed to leave the emergency stop mode.

3-76. Time delay. A time delay is built into the propulsion control panel and is used to sequentially set up a change of direction. This time delay (approximately 5 seconds) provides the time necessary for a motor controller to set up the starting sequence, to change the direction of a thruster motor. The status indicators show this time delay by illuminating half the indicator upon selecting the operation, and illuminating the other half after completion of the time delay, when the thruster motor is energized.

3-77. LIGHTING SYSTEM.

3-78. GENERAL. The lighting system provides exterior illumination for optical viewing through the viewports, television and 70mm camera operation, orientation and location of the vehicle on the surface, and operation of the vehicle, and interior illumination within the sphere. The lighting system is divided into groups of lights according to their particular function. These groupings consist of the TV lights, searchlights, floodlights, silo lights, recognition lights, navigation lights, and the internal lights. Table 3-1 lists the lights external to the sphere and indicates their type, location, source of power, and the controlling multiplex bottle. In order to prevent loss of lighting from a particular pan and tilt unit, should a multiplex bottle fail, the lights are each energized by different multiplex bottle. The same arrangement is also used for control of the floodlights and the silo lights.

3-79. LIGHTING CONTROL PANEL (Unit 700A15). Figure 3-12 shows the interconnection from the lighting control panel through the multiplex system, inverters, ballasts, contactors and pre-regulators to the TV, search, flood and silo lights. ON-OFF control for the TV, search, flood and silo lights originates at a switch on the lighting control panel (Unit 700A15, Figure 3-13) which closes to complete the circuit from a data bit input of the internal multiplex unit to the multiplex common circuit. This switch closure changes the condition of the data bit, and this change is sensed and transmitted to the appropriate external multiplex bottle. At the external multiplex bottle, the change is decoded, a relay is energized, and a control signal is sent to energize the appropriate power source, thus energizing the light. If the switch is placed in the OFF position, then the data bit input-multiplex common circuit is opened and the data bit condition is restored to its original position. This change is decoded in the external multiplex bottle, de-energizing the relay, turning off the control power and the light is extinguished.

NOTE

In the event of loss of data transmission between the internal and external multiplex units all lights energized will remain in that condition so long as the external-multiplex units remain energized. Lights can be de-energized by opening the control circuit of the external multiplex unit until data transmission is restored between the internal and external units.

3-80. Power Sources. The navigation lights are powered by a removable battery pack and activated by a switch on the battery pack. The recognition lights contain their own battery power and are activated by a pressure switch. The sphere internal lights are powered from the sphere 24-VDC power, by a switch on the master power panel (Unit 700A33). HIGH or LOW intensity control for the sphere lighting is provided by a switch on the lighting control panel (Unit 700A15).

3-81. The 24-VDC power for the lighting control panel is supplied via the EXTERNAL LIGHTS circuit breaker switch on the 24-VDC starboard power distribution panel (Unit 700A27), providing power for the 70mm indicator circuitry and internal multiplexer (Unit 700A211) through the multiplex channel circuit breakers. The 24-VDC power for the external lights, light contactors, invertors No. 7 and 8 and the external multiplex bottles is derived from the 24-VDC power distribution panel (Unit 804).

3-82. TV LIGHTS (Units 926, 927, 929, 933, 934, 936). The six TV lights have gas discharge type elements, three have thallium iodide elements (Units 926, 927, 929) and three have multi-vapor elements (Units 933, 934, 936). The units are all 400-watt lights and have a conical beam pattern of approximately 60 degrees. The TV lights are located with one light of each type element on each of the port, starboard and aft TV pan and tilt (P/T) mechanisms (Units 728, 727, and 729 respectively).

3-83. Circuits for control of the TV lights originate from switches on the lighting control panel (Unit 700A15), through the multiplex system to one of the 2kW inverters No. 7 or No. 8 (Units 924 and 931). In the inverter, a contactor is energized to provide 115 VAC, 60 Hz to one side of one of the multivapor ballast (Units 925, 928, 932 or 935) which then energizes the light. Table 3-1 shows the respective inverter and ballast unit for each light.

3-84. SEARCHLIGHTS (Units 705A1, 705A2, 930, 937). All four of the searchlights are mounted on the forward TV P/T mechanism (Unit 709). These lights are used primarily for lighting areas ahead or below the vehicle for viewing by TV camera and for visual observations by operators in the sphere. Searchlights No. 1 and No. 2 (Units 705A1 and 705A2) are 120-VDC, 500-watt incandescent light, with conical beam patterns of approximately 22 degrees. Control of these lights is provided from a single switch on the lighting control panel (Unit 700A15), through the multiplex system, to a contactor in the search pre-regulator No. 1 (Unit 704). When the contactor closes, regulated 120 VDC is applied to energize both lights.

3-85. Searchlights No. 3 and No. 4 (Units 930 and 937) are 400-watt thallium iodide gas discharge lights with a conical beam pattern of approximately 22 degrees. Control of each light is from a switch on the lighting control panel (Unit 700A15), through the multiplex system, to contactors in Inverter 7 or 8 (Units 924 and 931). When the contactor closes, 115 VAC, 60 Hz is provided to one side of a multivapor ballast, which energizes the light. Table 3-1 shows the respective inverter and ballast unit for each light.

3-86. SILO LIGHTS (Units 774, 775, 776, 777). There are four silo lights. Each is located on the underside of the vehicle near a shot valve magnet. The lights are mounted so that they direct their beam downward into the line of dropping shot, so that the dropping of shot can be viewed by the TV cameras and monitored by the operators in the sphere.

3-87. The silo lights are 24-VDC, 300-watt incandescent lamps, with a conical beam pattern of approximately 50 degrees. Control of the silo lights is provided from switches on the lighting control panel (Unit 700A15), through the multiplex system to contactors in lighting contactor bottles No. 1 and No. 2 (Units 713 and 714). Closing the contactor for a particular light provides 24 VDC through lighting junction blocks (Units 938 through 941) to the particular light. Table 3-1 shows the particular lighting contactor bottle and lighting junction block (JBL) associated with each light.

3-88. FLOODLIGHTS (Units 737 through 740). There are four floodlights mounted on the underside of the vehicle forward of the sphere. They are for illuminating the area directly ahead of the viewport, for direct viewing through the optical system. The manipulator arm is also located in this area, and the floodlights provide illumination for its operation. The floodlights are 24-VDC, 300-watts incandescent lights with conical beam pattern approximately 50 degrees. Control of these lights is identical to that for the silo lights (paragraph 3-86).

3-89. RECOGNITION LIGHTS. The vehicle is provided with two recognition lights. They are Model 2000-watt (Benthos) units and are mounted in the forward part of the sail. The lights are self-contained units consisting of a high-intensity xenon flasher, battery power supply, and pressure sensitive switch. The pressure sensitive switch is normally closed, opening with a pressure of 38 psi on descent, and closing with a pressure of 21 psi on ascent. These lights are used for detecting the vehicle upon its surface ascent, particularly at night. A shorting dummy plug is required in order for the light to operate.

3-90. NAVIGATION LIGHTS. The navigation lights are required in order to meet the standard international navigation requirements for identifying the course of travel or position at anchor for small vehicles. This is particularly important for identification at night or during bad weather.

3-91. The system consists of four removable lights, a removable battery pack, and associated cabling. The lights are mounted on fixed foundations - red light, port side of the sail; green light, starboard side of the sail; white light on the stern; and white anchor light on the sail mast. These lights are connected by cabling to the battery pack in the sail. The battery pack has a switch for energizing the lights and contains eight Yardney LR100DC silver-cells connected in series for 12-VDC, 100-Ah operation. This lighting system is not designed for submergence and must be removed before a dive, and re-installed after a dive.

3-92. INTERIOR LIGHTS (SPHERE). The interior lights are contained in fixtures at the top of Bays 1 through 8. The lights use 24 VDC and are controlled by a two-position switch on the lighting control panel (Unit 700A15). The HI position energizes all four lights in each fixture, and the LO position energizes two lights in each fixture.

3-93. LIGHTING CONTROL PANEL (Unit 700A15). The lighting control panel, (Figure 3-13) is located in Bay 1 and contains controls for internal and external lighting, 70mm camera operation, and control power for the multiplex system. Operation of the lighting control panel for 70mm camera operation and multiplex power is provided in their individual system descriptions.

3-94. External Lighting Control. The external lighting controls on the lighting control panel are switches, which when closed, complete a circuit from a particular data bit input of the internal multiplex (Unit 700A11) to a respective multiplex common circuit. This changes the status of a particular multiplex data bit and this change is transmitted to the respective external multiplex unit. This unit detects the data bit change and energizes a relay providing control power to the power source energizing the light. Opening the switch changes the data bit status back, the external multiplex unit detects the change, de-energizes the relay, and the light is extinguished.

3-95. Internal Lighting Control. The control switch for the sphere internal lighting, selects either two or four lights per fixture. The selected combination is energized by 24 VDC from the sphere lights breaker on the master power panel (Unit 700A33).

3-96. MULTIVAPOR BALLASTS (Units 925, 928, 932, 934). Four multivapor ballast units are located on the horizontal stabilizer structure in the aft part of the vehicle. Each ballast unit is capable of providing the starting voltage and changing impedance required for current stabilization. The ballast units output powers two multivapor or thallium iodide gas discharge lights.

3-97. The ballast units are oil filled and are equipped with a bladder on one end which is open to the sea pressure to provide self-compensation. The internal components consist of one transformer and one capacitor in each circuit to provide the starting voltage and constant current to illuminate the light. The ballast units also provide constant current after initial illumination for constant light output. The 115-VAC, 60-Hz power input to the ballasts is supplied from inverter No. 7 (Unit 924), for ballasts No. 1 and No. 2 (Units 925 and 928) and from inverter No. 8 (Unit 931), for ballasts No. 3 and No. 4 (Units 932 and 934). Table 3-1 shows the ballast used to energize a particular light.

3-98. SEARCH PRE-REGULATOR (Unit 704). The search pre-regulator is mounted on the starboard side, bottom, center of the vehicle. The lighting pre-regulator receives 120 VDC from the 120-volt distribution panel (Unit 810) and then provides constant 120 VDC output to the two incandescent searchlights (Units 705A1 and 705A2). A contactor in the pre-regulator, controlled from the forward multiplex bottle closes to provide the 120 VDC to the electronic switching network. The switching network provides the regulated 120 VDC to energize the lights. The voltage regulation prolongs the life of the lights. Output power is provided to both searchlights at the same time.

3-99. LIGHTING CONTACTOR BOTTLE NO. 1 (Unit 713). Lighting contactor bottle No. 1, located on the portside, bottom, center of vehicle, receives 24 VDC from the 24-volt distribution panel (Unit 804), and feeds five contactors in the pressure proof bottle. Control signals from the port external multiplex bottle are used to energize the contactors. This provides 24 VDC through lighting junction box (JBL-1A) to the forward starboard floodlight, and power to the port 70mm camera, and strobe; and lighting junction box (JBL-1B) to the after port floodlight, the after port silo light, and forward starboard silo light.

3-100. LIGHTING CONTACTOR BOTTLE NO. 2 (Unit 714). Lighting contactor bottle No. 2, located on the starboard side, bottom, center of the vehicle, receives 24 VDC from the 24-volt distribution panel (Unit 804) and feeds five contactors in the pressure proof bottle. Control signals from the forward external multiplex bottle are used to energize the contactors. The 24-volt outputs of the contactors go through lighting control junction box (JBL-2A) to the forward port floodlight and both the after and starboard 70mm cameras and strobes, and through lighting control junction box (JBL-2B), to the after starboard silo light, after starboard floodlight and forward port silo light.

3-101. OPTICAL SYSTEMS. The vehicle is provided with two optical viewing systems, the after pephole optics, and the main or forward viewport optics.

3-102. After Peephole Optical System. The aft peephole optical system is primarily used for viewing the shot falling from the after shot tubs. The system consists of a telescope type (approximately 1 power) device with an adjustable focus. The optics are held in a fixed position in Bay 9, for viewing through the after peephole.

3-103. Main (Forward) Optical System. The main or forward viewport optical system consists of an optical viewer (Kollmorgen) which is used for viewing the work area directly ahead of and below the sphere. The optical viewer is located between Bays 1 and 2 in the sphere and is mounted on a swivel mechanism which allows for viewing at different angles through the viewport. The viewer is provided with two independent eyepieces, which may be brought together for stereoscopic viewing by one person, or separated for monocular vision by two people. Each eyepiece has an adjustable forehead rest and adjustable focus. The viewer has provision for two different magnifications, selected by adjustment of a lever on the leftside of the viewer. The high power gives a field of 72 degrees and a magnification of 1 power and the low power gives a field of 120 degrees and a magnification of .45 power. The viewer is internally pressurized with dry nitrogen to avoid moisture fogging the inside lenses.

Table 3-1. Lighting System Components and Locations

LIGHTING COMPONENTS

UNIT	LIGHT	TYPE	WATTAGE	SOURCE OF POWER	CONTROLLING MULTIPLEX BOTTLE	LOCATION
926	Port TV #1	TI	400	115VAC Inv #7, Ballast #1	Stbd	Port P&T
934	Port TV #2	MV	400	115VAC Inv #8, Ballast #3	Aft	Port P&T
927	Aft TV #1	TI	400	115VAC Inv #7, Ballast #1	Stbd	Aft P&T
936	Aft TV #2	MV	400	115VAC Inv #8, Ballast #3	Aft	Aft P&T
929	Stbd TV #1	TI	400	115VAC Inv #7, Ballast #2	Stbd	Stbd P&T
933	Stbd TV #2	MV	400	115VAC Inv #8, Ballast #4	Aft	Stbd P&T
705A1	Fwd Search #1	INC	500	120 VDC Pre-Regulator	Fwd	Fwd P&T
705A2	Fwd Search #2	INC	500	120 VDC Pre-Regulator	Fwd	Fwd P&T
930	Fwd Search #3	TI	400	115VAC Inv #7, Ballast #2	Stbd	Fwd P&T
937	Fwd Search #4	TI	400	115VAC Inv #8, Ballast #4	Aft	Fwd P&T
777	Aft Stbd Silo	INC	300	24VDC Ltg Contactor #2 JBL-2B	Fwd	Stbd of Aft Silo
776	Aft Port Silo	INC	300	24VDC Ltg Contactor #1 JBL-1B	Port	Port of Aft Silo
775	Fwd Stbd Silo	INC	300	24VDC Ltg Contactor #1 JBL-1B	Port	Arranged near re- spective shot silo
774	Fwd Port Silo	INC	300	24 VDC Ltg Contactor #2 JBL-2B	Fwd	

Table 3-1. Lighting System Components and Locations (Continued)

UNIT	LIGHT	TYPE	WATTAGE	SOURCE OF POWER	CONTROLLING MULTIPLEX BOTTLE	LOCATION
737	Fwd Stbd Flood	INC	300	24VDC Ltg Contactor #1 JBL-1A	Port	Arranged near Manip Area Fwd of Sphere
738	Fwd Port Flood	INC	300	24VDC Ltg Contactor #2 JBL-2A	Fwd	
739	Aft Stbd Flood	INC	300	24VDC Ltg Contactor #2 JBL-2B	Fwd	
740	Aft Port Flood	INC	300	24VDC Ltg Contactor #1 JBL-1B	Port	
	Recognition Light #1	XENON STROBE	2000	Internal Batteries Pressure Switch	N/A	Sail
	Recogniton Light #2	XENON STROBE	2000	Internal Batteries Pressure Switch	N/A	Sail
	Navigation Light #1	INC WHITE		Removable Battery Pack in Sail	N/A	Sail Post (Anchor)
	Navigation Light #2	INC RED		Removable Battery Pack in Sail	N/A	Port Sail
	Navigation Light #3	INC GRN		Removable Battery Pack in Sail	N/A	Stbd Sail
	Navigation Light #4	INC WHITE		Removable Battery Pack in Sail	N/A	Stern

Table 3-1. Lighting System Components and Locations (Continued)

POWER COMPONENTS

ITEM	UNIT
Inverter No. 7	924
Inverter No. 8	931
Multivapor Ballast No. 1	925
Multivapor Ballast No. 2	928
Multivapor Ballast No. 3	932
Multivapor Ballast No. 4	935
Lighting Contactor No. 1	713
Lighting Contactor No. 2	714
JBL-1A	938
JBL-1B	939
JBL-2A	940
JBL-2B	941
Pre-Regulator	704

3-104. SAFETY SYSTEMS.

3-105. GENERAL. The safety systems provided for the vehicle include the emergency breathing system, emergency release mechanisms, emergency pinger, master alarm system and the antechamber blow system. The emergency breathing system provides emergency oxygen (3 persons, 23 hours) and a means for emergency communication if the air in the sphere becomes contaminated. The system is discussed in detail in Chapter 5 (5-31). The emergency release mechanisms are systems which jettison non-essential external equipment to provide more buoyancy. These are discussed in detail in Chapter 6 (6-37). The emergency pinger transmits a distress signal when activated by an operator from within the sphere. This is a secondary (backup) method of communication and is discussed in Chapter 4.

3-106. MASTER ALARM SYSTEM. The master alarm system (Figure 3-14) monitors the systems listed in Table 3-2 and provides audible (horn) and visual (illuminated panel indicators) alarms in the event of failure or unsatisfactory

operating conditions. The horn may be reset, but the indicator light remains on until the alarm condition is repaired.

3-107. Master Alarm Panel (Unit 700A02). The master alarm panel (Figure 3-15) is located at the top of Bay 2 and is powered from the essential bus in the master power panel (Unit 700A33) (Chapter 3). The panel has 11 indicator lights, a PERCENT OXYGEN meter, CALIBRATE switch and sensor (a REMOTE SENSOR jack is also provided), a HORN RESET/ON/OFF switch and a LAMP TEST button on the front face. All of the indicator lamps on the panel can be tested simultaneously by depressing the LAMP TEST button. The HORN RESET/ON/OFF switch (a center return, spring-loaded toggle) is spring loaded from the RESET to ON positions and snap actuated from OFF to ON. The switch is used to silence the alarm horn by placing it in either the RESET or OFF position, and then back to the ON position. The PERCENT OXYGEN meter is a self-contained unit and monitors the percent of oxygen in the sphere atmosphere and displays the reading on the meter.

NOTE

The PERCENT OXYGEN meter serves as the back-up O₂ sensor and is not connected to the O₂/CO₂ BALANCE alarm.

Table 3-2. Systems Monitored by Master Alarm System

SYSTEM	ALARM CONDITION
Essential power	Switch over from 24V main battery to essential battery
24V-Battery low charge	24V Battery 75% discharged
120V-Battery low charge	120V Battery 75% discharged
24VDC-Low voltage	Low 24V cell voltage
120VDC-Low voltage	Low 120V cell voltage
Scrubber flow	No air flow through CO ₂ Scrubber
O ₂ /CO ₂ Balance	High percentage of CO ₂ , Low percentage of O ₂
Thermoelectric Unit	T/E Unit automatic shutdown due to self-contained emergency procedures
UQC temperature	High temperature of UQC transmit unit
Computer air flow	Computer fan not working
60 Hz-Inverter air flow	Inverter fan not working

3-108. ANTECHAMBER BLOW SYSTEM.

3-109. GENERAL. The antechamber blow system (Figure 3-16) is used to blow water out of the access trunk at the completion of the dive. The antechamber blow panel (Unit 700A23) is located in Bay 9 and powered from the essential bus of the master power panel (Unit 700A33).

3-110. The panel is used to control the system blow valve (AHP-1) motor through a cam-actuated microswitch. These components are located in a pressure-compensated unit, inside the aft, upper port side of the sail. The discharge for the blow valve is located at the top port side, inside the access trunk. In addition to opening and shutting the valve by providing for control of the motor, the panel also indicates the OPEN/CLOSE position of the blow valve.

3-111. Operation. Normal operating procedure for the blow system calls for flooding the access trunk prior to diving and blowing the trunk free of water with high pressure air upon surfacing. The flood valve is shut prior to diving and cannot be operated from inside the sphere.

3-112. BUOYANCY CONTROL SYSTEM.

3-113. GENERAL. The buoyancy control system (Figure 3-17) provides for precise control of the vehicle's buoyancy during all phases of operation. This control is accomplished by either dropping shot or venting aviation gasoline (AVGAS) in order to maintain vertical control of the vehicle. The buoyancy control system consists of the following units:

1. Ballast control panel - (Unit 700A22)
2. Trail ball winch assembly - (Unit 765)
3. Trail ball winch control assembly - (Unit 766)
4. Forward starboard shot silo valve - (Unit 831)
5. Forward port shot silo valve - (Unit 832)
6. Aft starboard shot silo valve - (Unit 833)
7. Aft port shot silo valve - (Unit 834)
8. Maneuvering gas valve No. 1 - (Unit 835)
9. Maneuvering gas valve No. 2 - (Unit 836)
10. Maneuvering gas valve No. 3 - (Unit 837)
11. Bow device release mechanism - (Unit 838)
12. Manipulator arm release mechanism - (Unit 839)

13. Port shot silo release mechanism - (Unit 840)
14. Starboard shot silo release mechanism - (Unit 841)
15. Aft shot silo release mechanism - (Unit 843)
16. Trail ball winch release mechanism - (Unit 844)
17. Centerline device release mechanism - (Unit 845)

3-114. BALLAST CONTROL PANEL (Unit 700A22). The ballast control panel (Figure 3-18) is located inside the sphere in Bay 4 and provides the means for maintaining precise vertical control of the vehicle. The panel contains the controls and indicators for the following functions:

1. Adjusting Buoyancy - accomplished by dropping shot ballast and venting aviation gasoline.
2. Altitude Control Near Bottom - desired altitude is maintained by winching in or out the length of extended cable to a trail ball that is dragged along the bottom.
3. Jettisoning - the shot tubs and various equipment may be jettisoned by interrupting current to the holding magnets that retain their support mechanisms.
4. Additional Functions - the panel also contains a time clock, a voltmeter, a voltmeter selection switch, an illumination switch and test points for checking resistance to ground of vital circuits. The ascent/descent rate of the vehicle is also displayed on the panel from data provided by the navigation computer (Unit 700A30).

3-115. Shot Ballast Operation. Dropping of shot ballast from as many as four valves is accomplished by interrupting the current to the shot valve coils that maintain a shot restraining magnetic field in the silo exit orifice. Momentary pushbutton (DROP) switches on the panel are used to interrupt the coil circuit. The four shot valves provide for a total shot dropping rate of approximately 60 pounds per second (14 to 17 pounds per second per valve). Additional controls are provided to reverse the direction of current flow to demagnetize the valves. This is done if residual magnetism prevents dropping of the shot when the current is interrupted. CURRENT HI-LOW switches are also provided on the panel to by-pass current limiting resistors in the control circuit to increase the magnetic field in the valve coils. These switches are used if the normal field is not sufficient to stop the dribbling of shot. Meters are provided on the panel to permit monitoring of individual valve circuit currents.

3-116. AVGAS Venting Operation. The release of AVGAS is accomplished by push-button (VENT) switches which are used to energize solenoid valves. Timers associated with the VENT switches are also provided and may be preset to maintain the valves open for a desired interval following switch actuation. The

amount of current required to open the valves is greater than that required to maintain them opened. Therefore, the pushbuttons apply nearly full voltage across the solenoids, while the time-controlled contacts maintain the valves opened through series current-limiting resistors.

3-117. Blinking lamps on the panel warn the operator whenever the vent valve control circuits are in a state that maintains the AVGAS valve open. Meters are provided to permit monitoring of the current to the valve solenoids while the valves are open. These meters are momentarily bypassed when high opening currents are flowing in the circuit following initial actuation of the push-buttons.

3-118. The shot and AVGAS valve control circuits provide direct and simple control of the vehicle's buoyancy. Built-in safety measures incorporated in the panel include the associated displays and convenience controls: 1) time totaling numerical counters that indicate the cumulative period that each shot valve and each AVGAS tank valve has been opened; 2) gasoline valve timers and; 3) AVGAS "valve open" lamps, which operate from power sources separate from those used to directly control ballast. In the event the momentary (DROP) switch fails, the shot valves may be controlled by the shot CURRENT HI-LOW switch and the protected circuit breaker/switch associated with each valve.

3-119. The jettisoning of the mechanical arm, trail ball winch assembly, bow and centerline devices, and the shot tubs is accomplished by tripping separate circuit breakers on the panel which are protected by dual covers. A spare circuit breaker is provided for jettisoning an additional mission-oriented appendage.

3-120. Panel Clock. A Bulova Accutron clock is provided on the panel and is powered by a self-contained battery which is replaced approximately once a year. The time clock incorporates a pair of contacts that close and open once per second. These contacts are used as a time reference input to the electronic circuits that drive the shot and AVGAS time totaling numerical counters and gasoline venting lamps. A motor actuated back-up timer is also provided on the panel to control the timing mechanisms if the main clock fails.

3-121. TRAIL BALL WINCH AND CABLE TENSION SENSOR SYSTEM. The trail ball winch and cable tension sensor system (Figure 3-19) provides a means for establishing the height, up to 65 feet, that the vehicle maintains above the ocean bottom during periods of observation, either hovering or moving. The TRAIL ROPE WINCH section of the ballast control panel provides control of the winch and information on the length of rope payed out and the tension on the rope.

3-122. EMERGENCY RELEASE MECHANISMS. Emergency buoyancy control for the vehicle is provided by releasing (dropping) external, non-essential equipment (see Figure 3-20). This includes the shot silos, bow device, centerline device, manipulator arm, and trail ball winch. Each piece of equipment is installed with a release mechanism operated from the ballast control panel. All cabling to this equipment is provided with a "Weak Link" section and/or a guillotining device for severing the cable when the equipment is dropped. The emergency release system is discussed in detail in chapter 6.

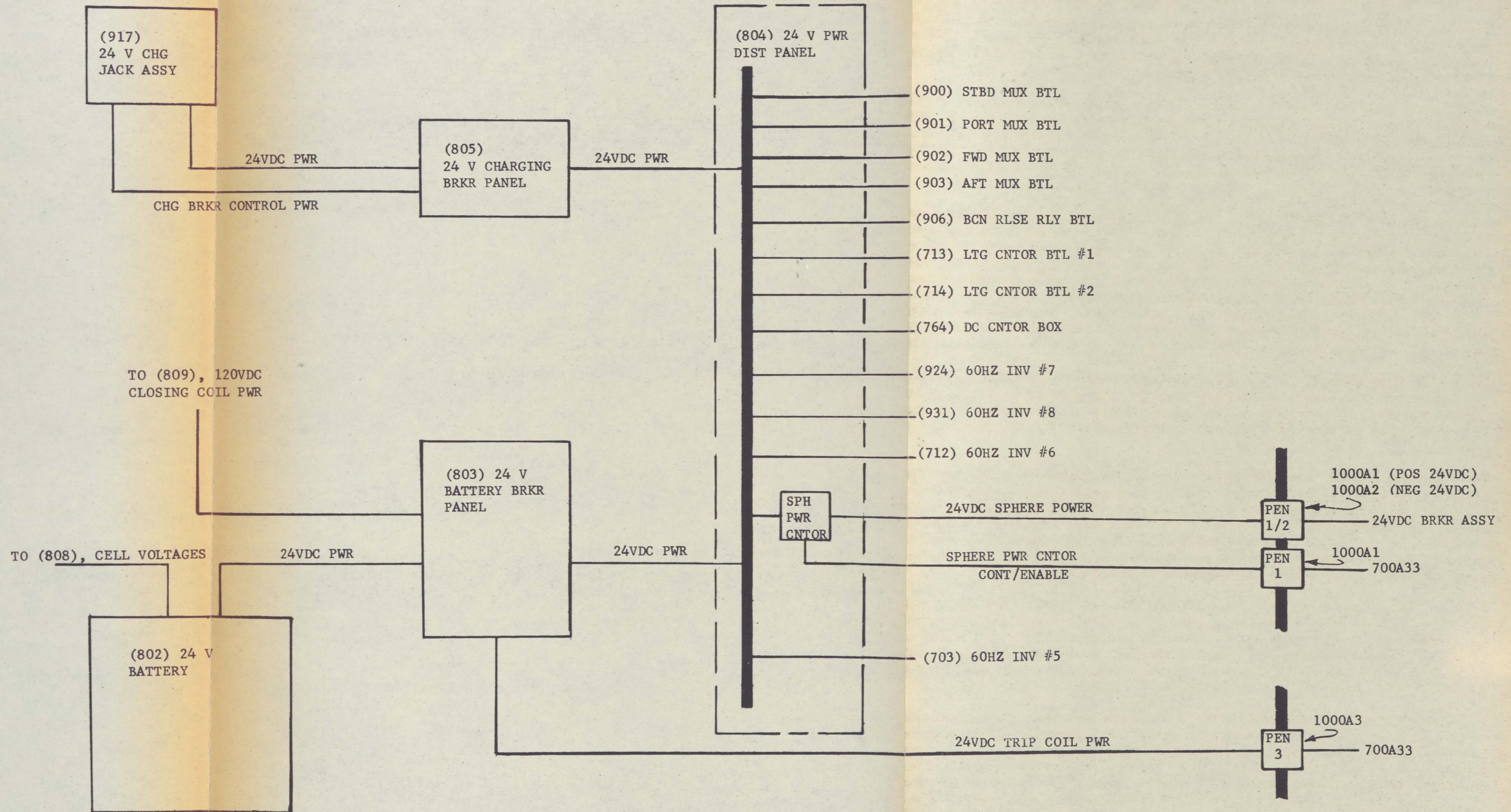

FIGURE 3-1. 24VDC EXTERNAL POWER DISTRIBUTION SYSTEM

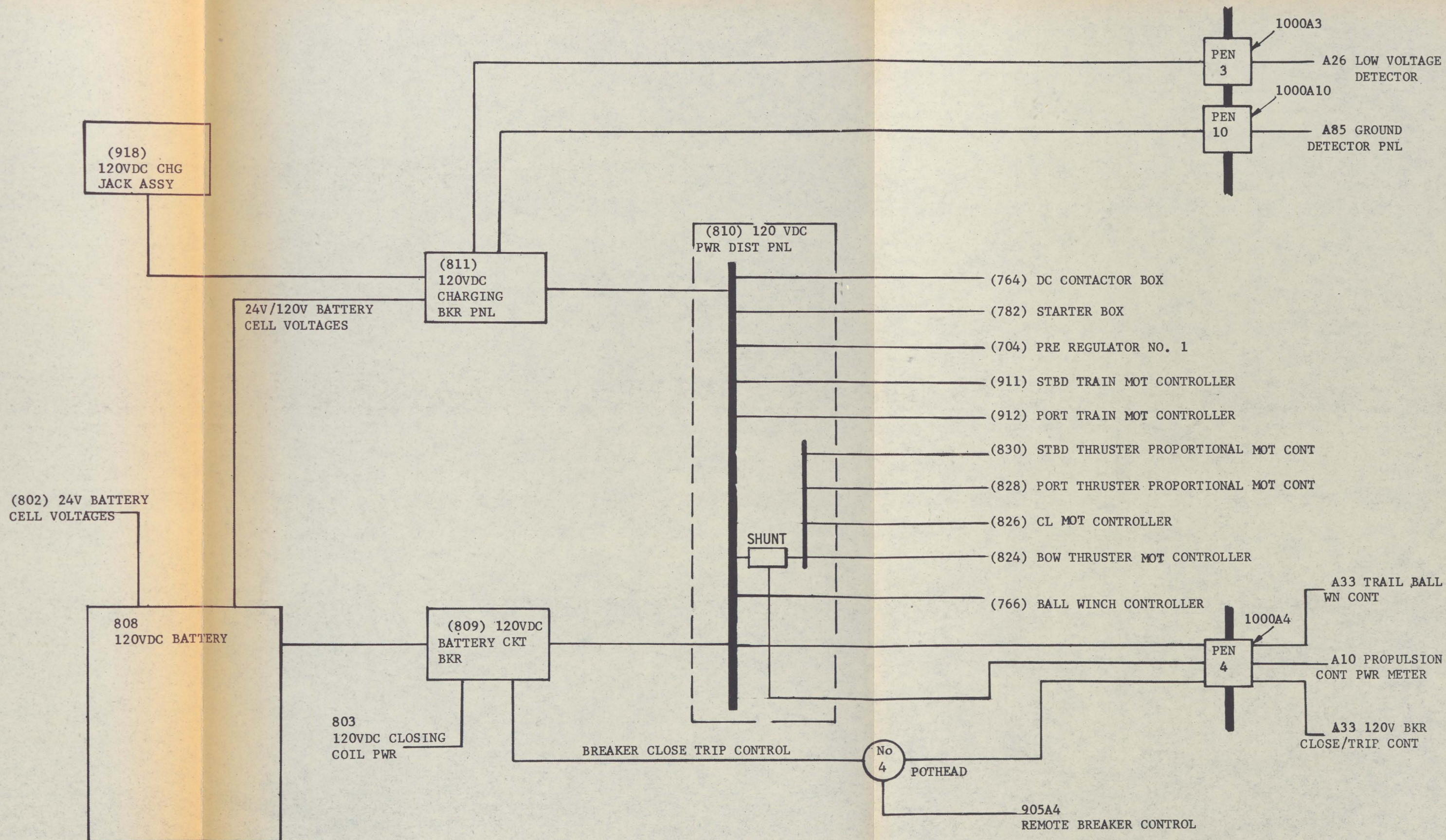

FIGURE 3-2. 120 VDC POWER DISTRIBUTION SYSTEM

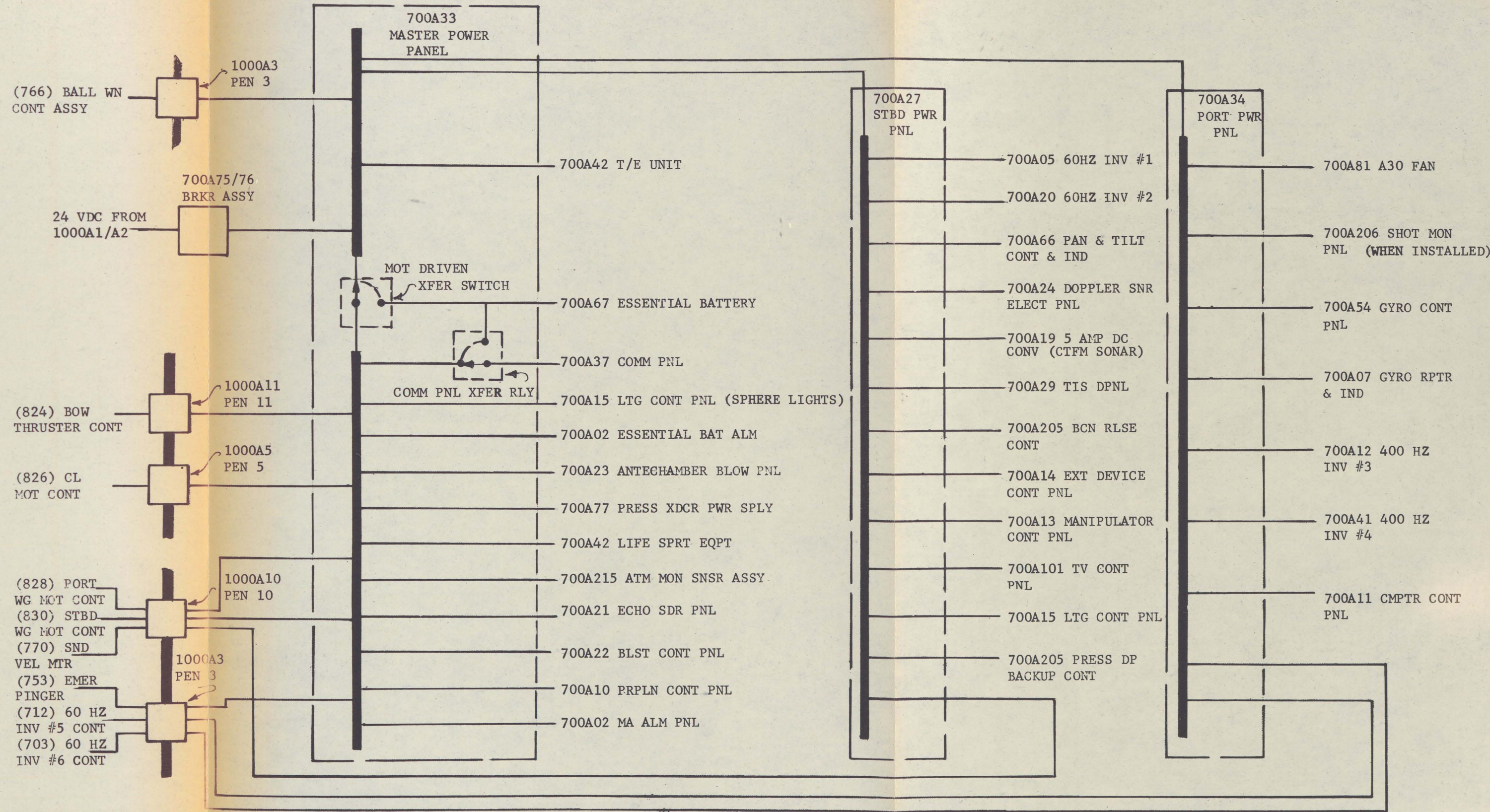

FIGURE 3-3. 24VDC SPHERE POWER DISTRIBUTION SYSTEM

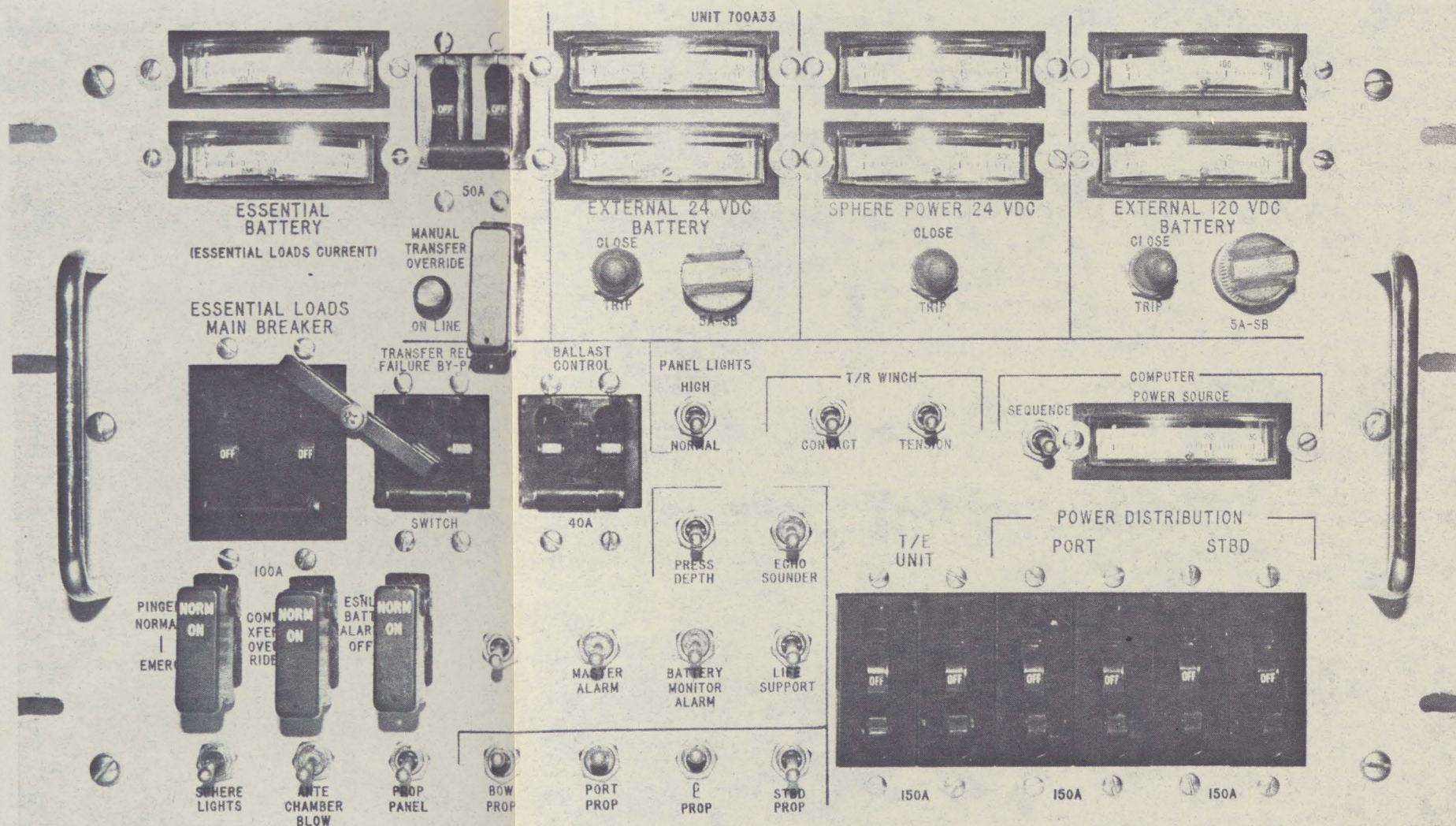

FIGURE 3-4. MASTER POWER PANEL

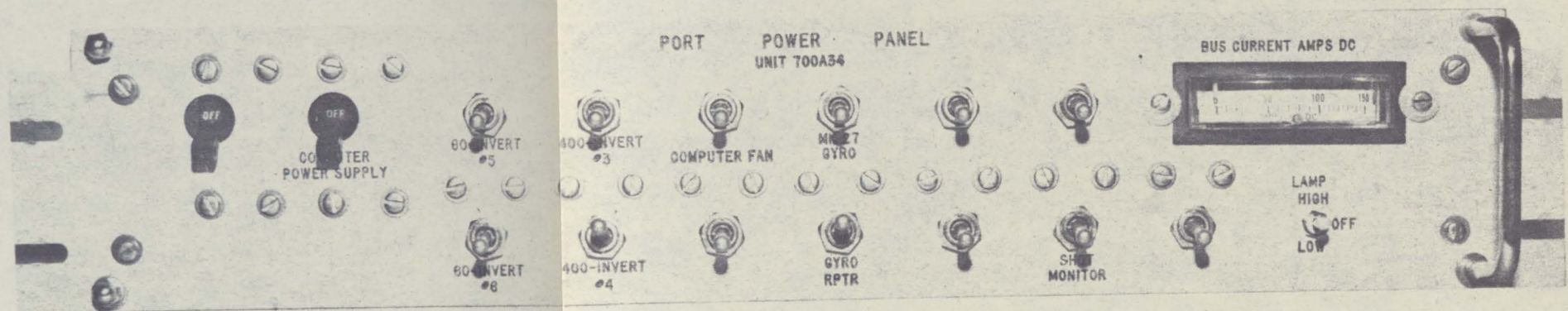

FIGURE 3-5. PORT POWER PANEL

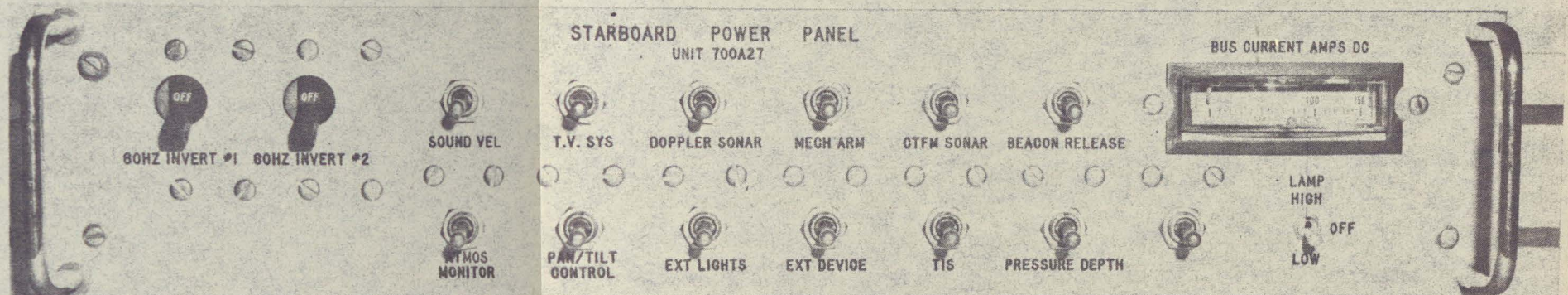

FIGURE 3-6. STARBOARD POWER PANEL

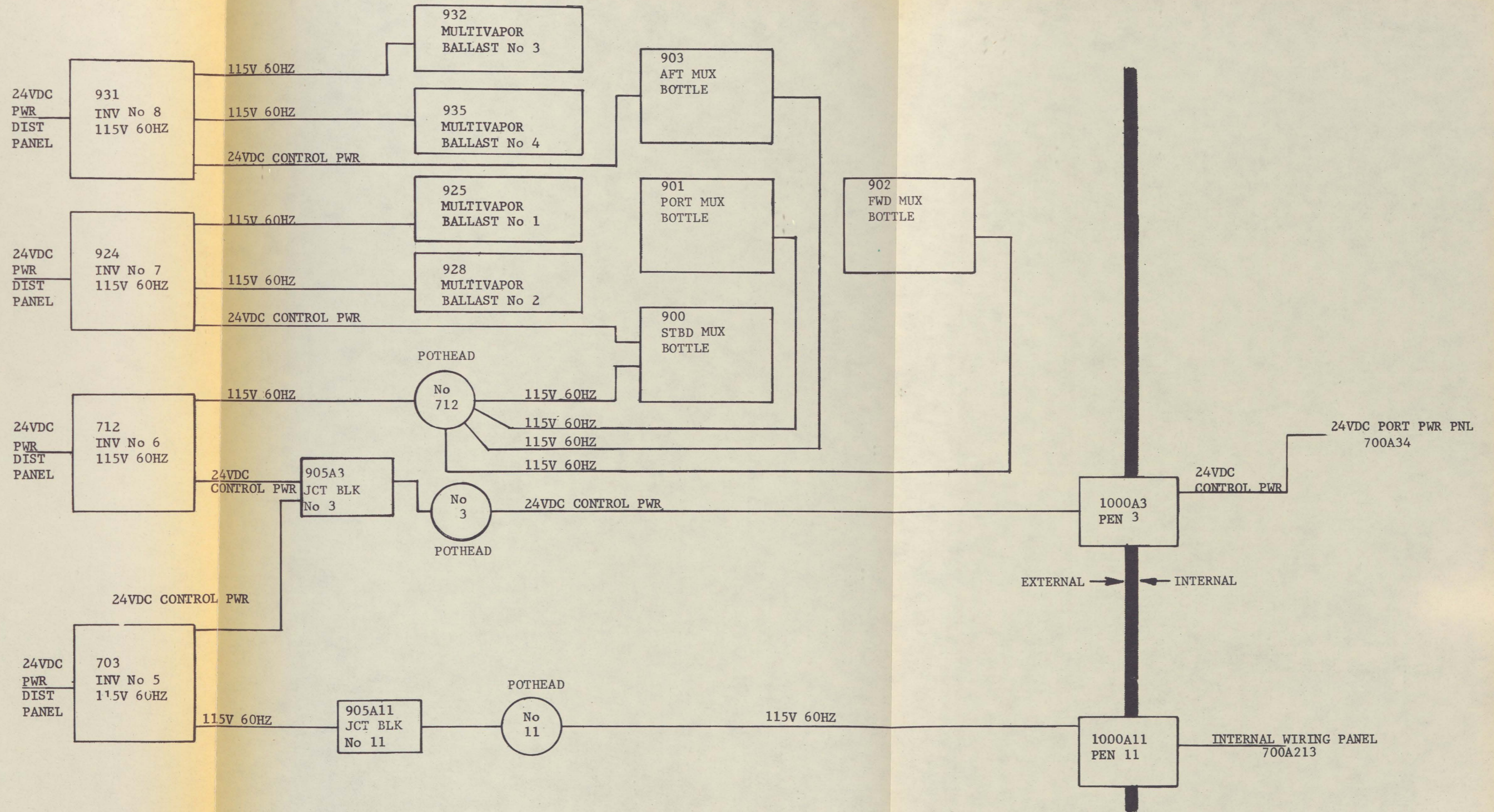

FIGURE 3-7. EXTERNAL AC POWER DISTRIBUTION SYSTEM

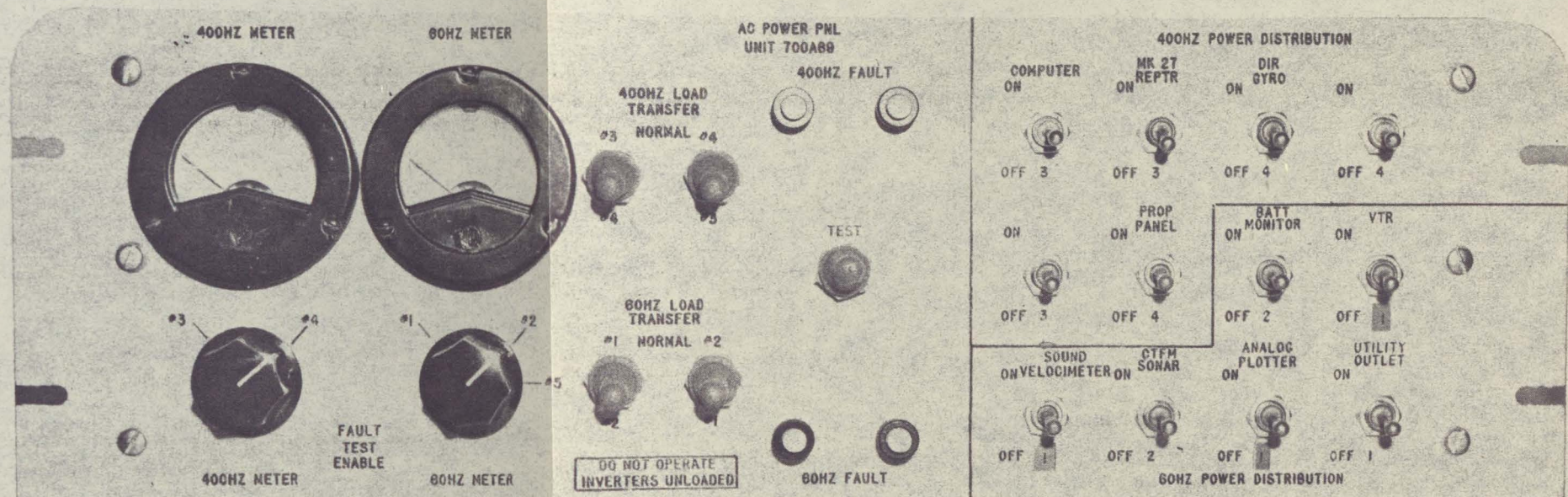

FIGURE 3-8. AC POWER PANEL

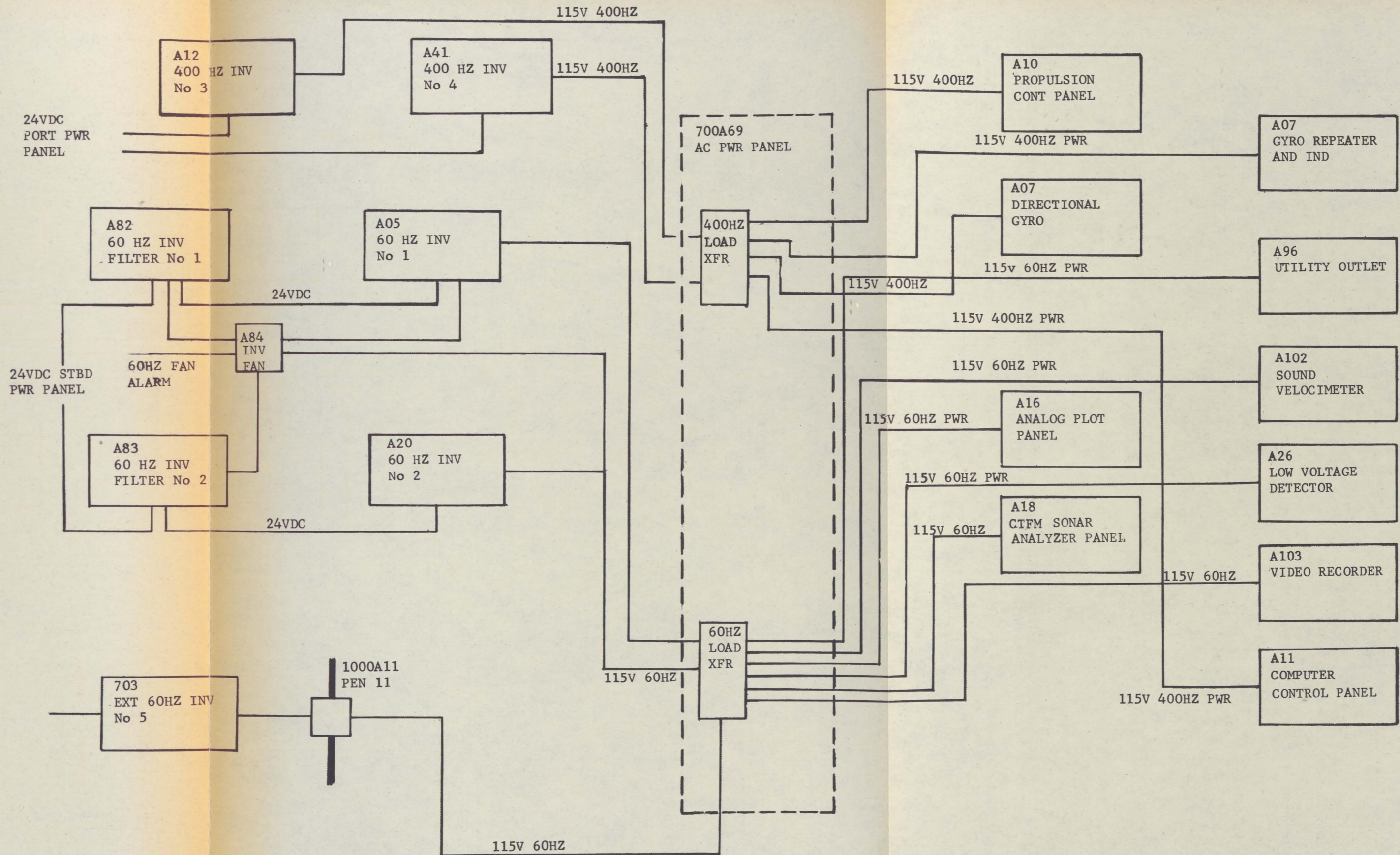

FIGURE 3-9. INTERNAL AC POWER DISTRIBUTION

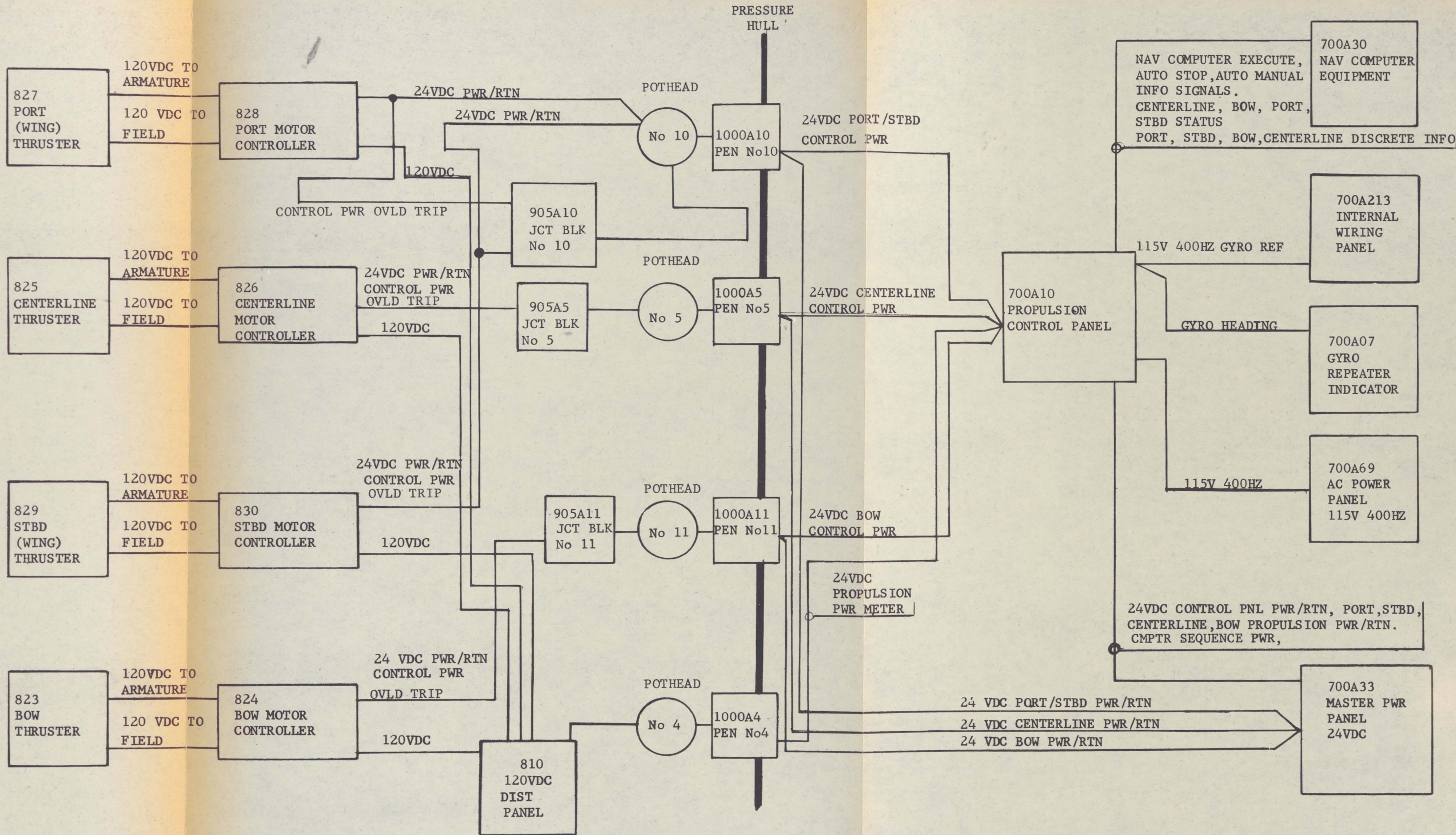

FIGURE 3-10. PROPULSION SYSTEM POWER AND CONTROL DIAGRAM

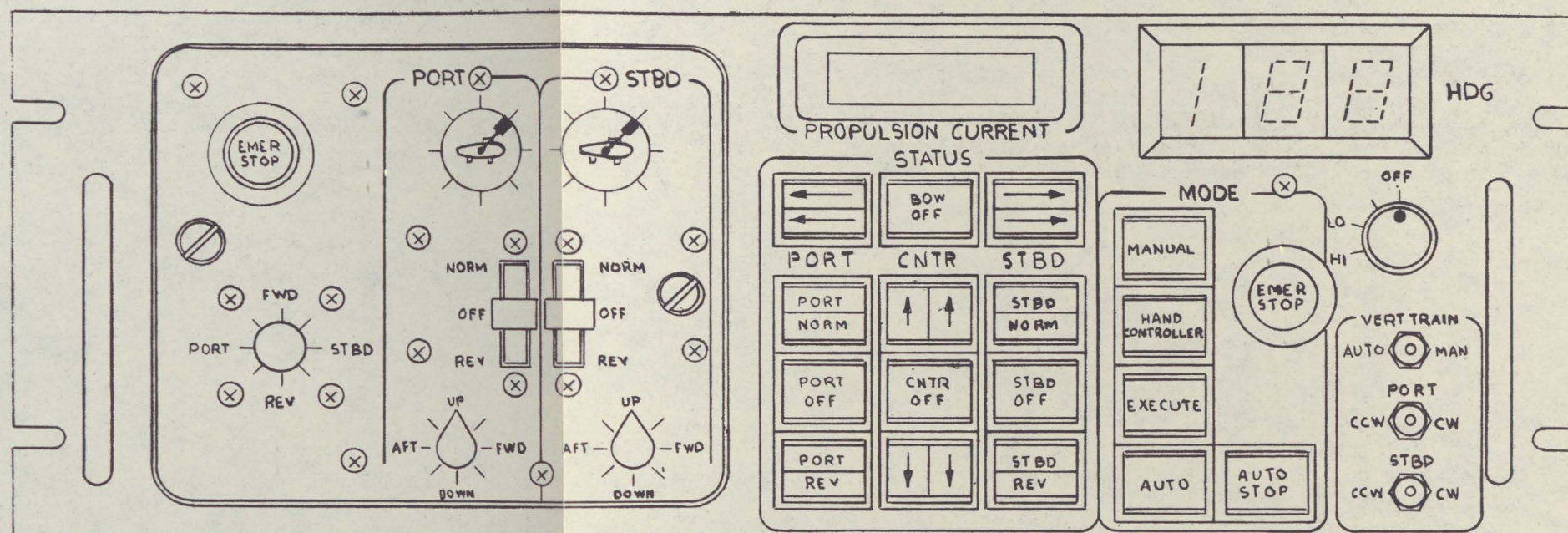
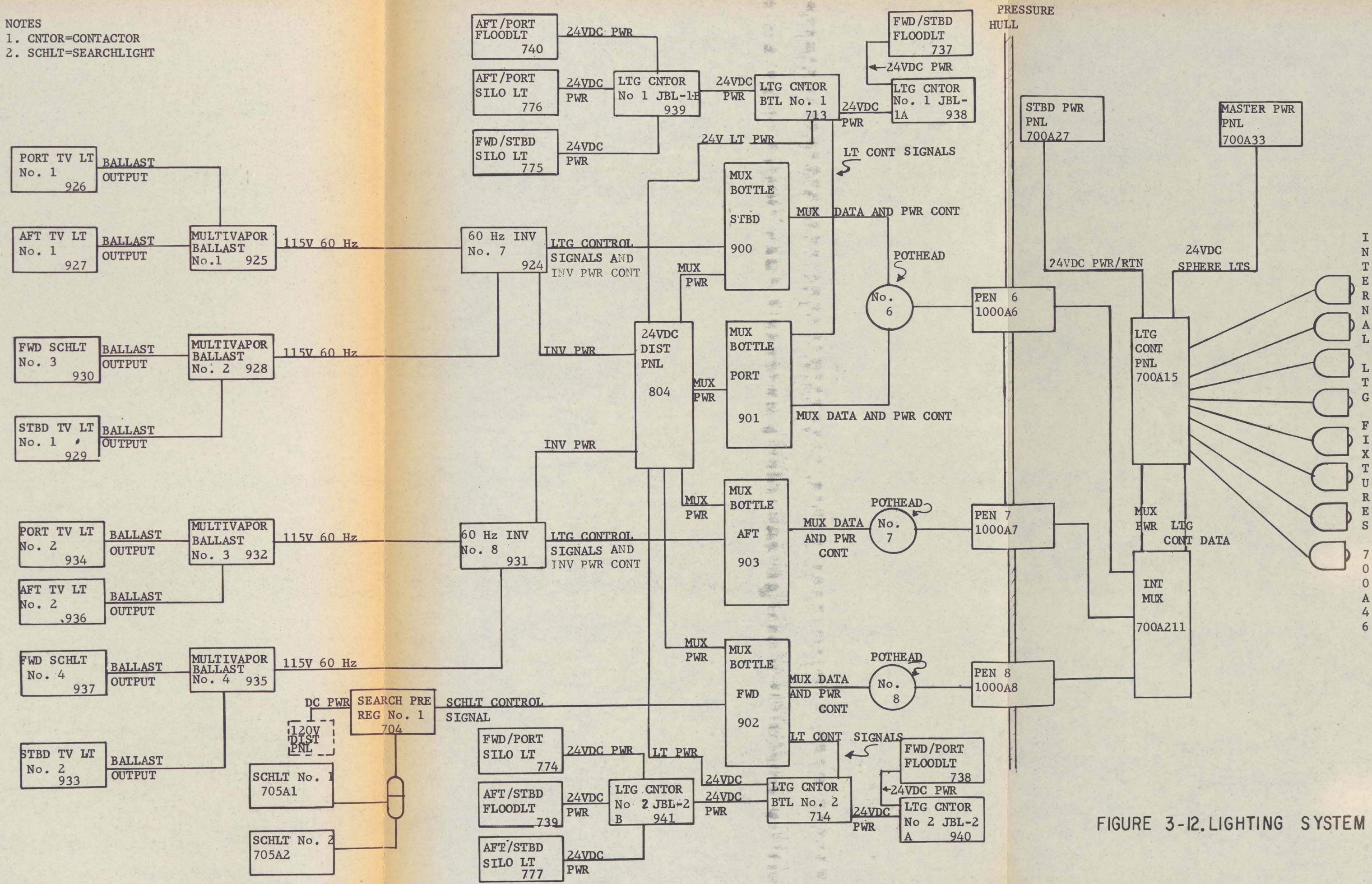

FIGURE 3-II. PROPULSION CONTROL PANEL

NOTES
 1. CNTOR=CONTACTOR
 2. SCHLT=SEARCHLIGHT



INTERNAL LIGHT FIXTURES 700A46

FIGURE 3-12. LIGHTING SYSTEM BLOCK DIAGRAM

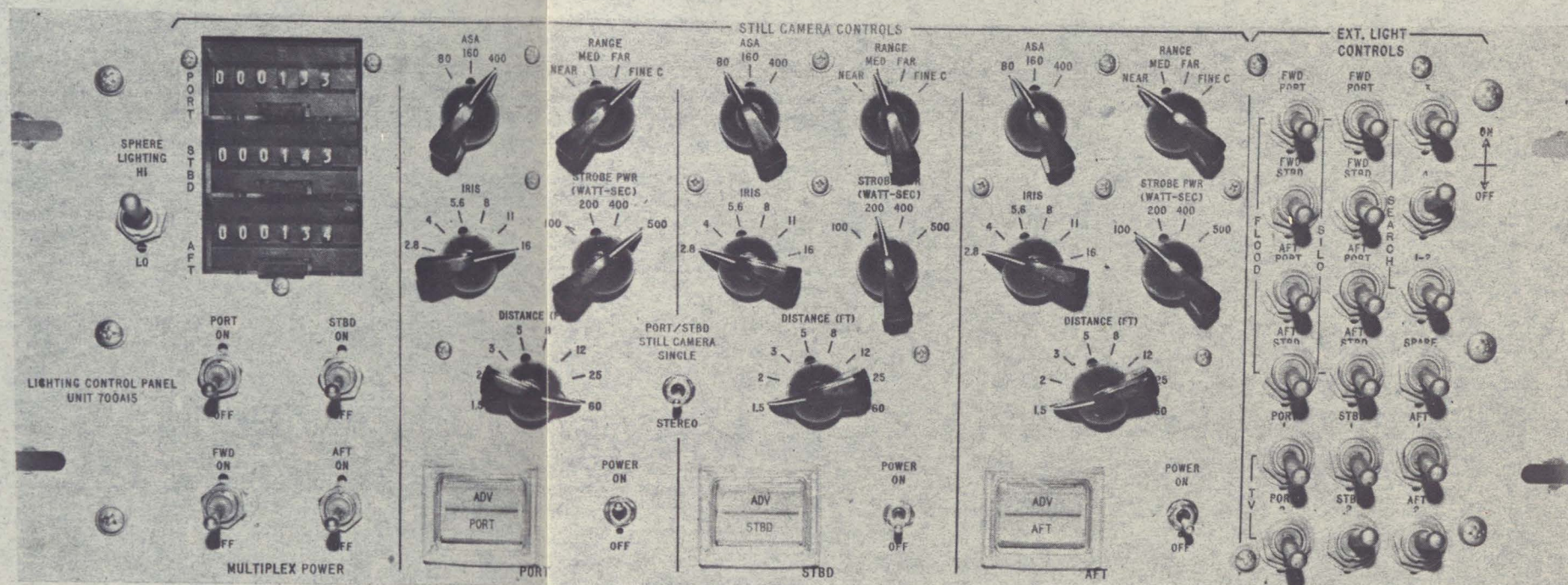

FIGURE 3-13. LIGHTING CONTROL PANEL

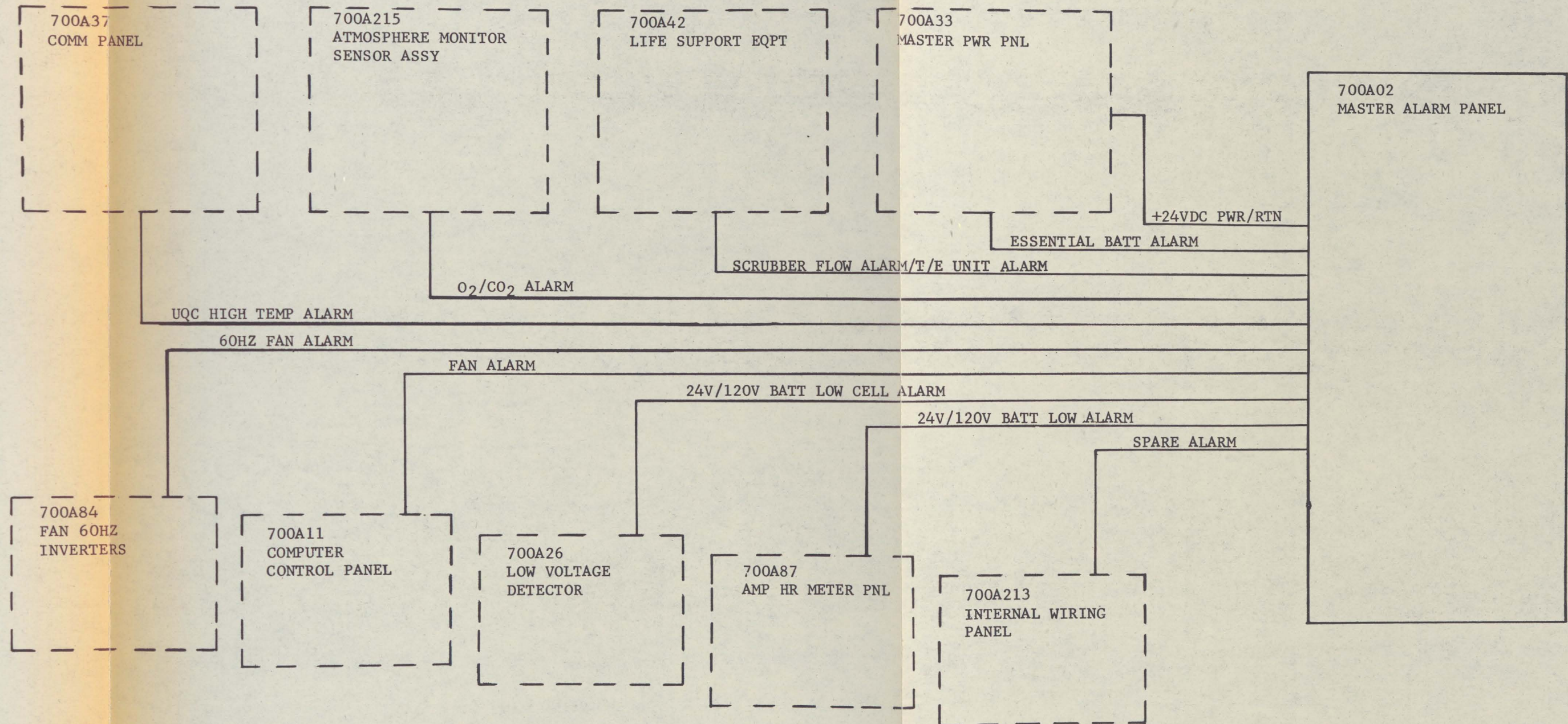

FIGURE 3-14. MASTER ALARM SYSTEM

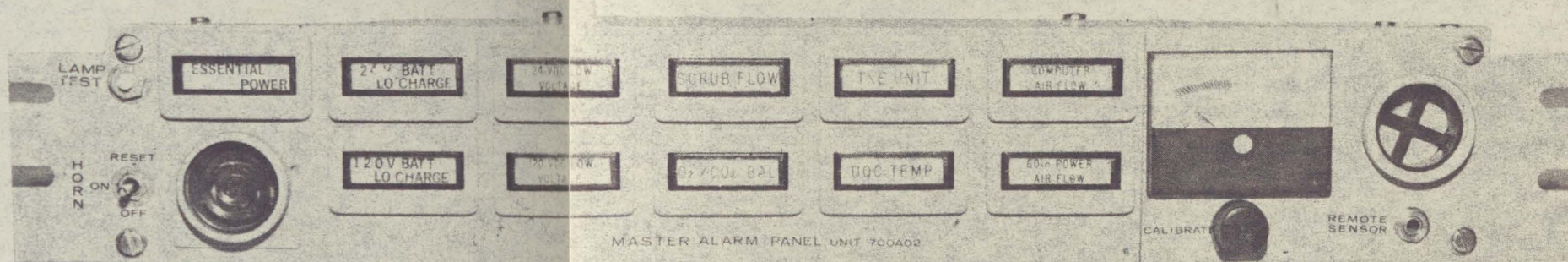

FIGURE 3-15. MASTER ALARM PANEL

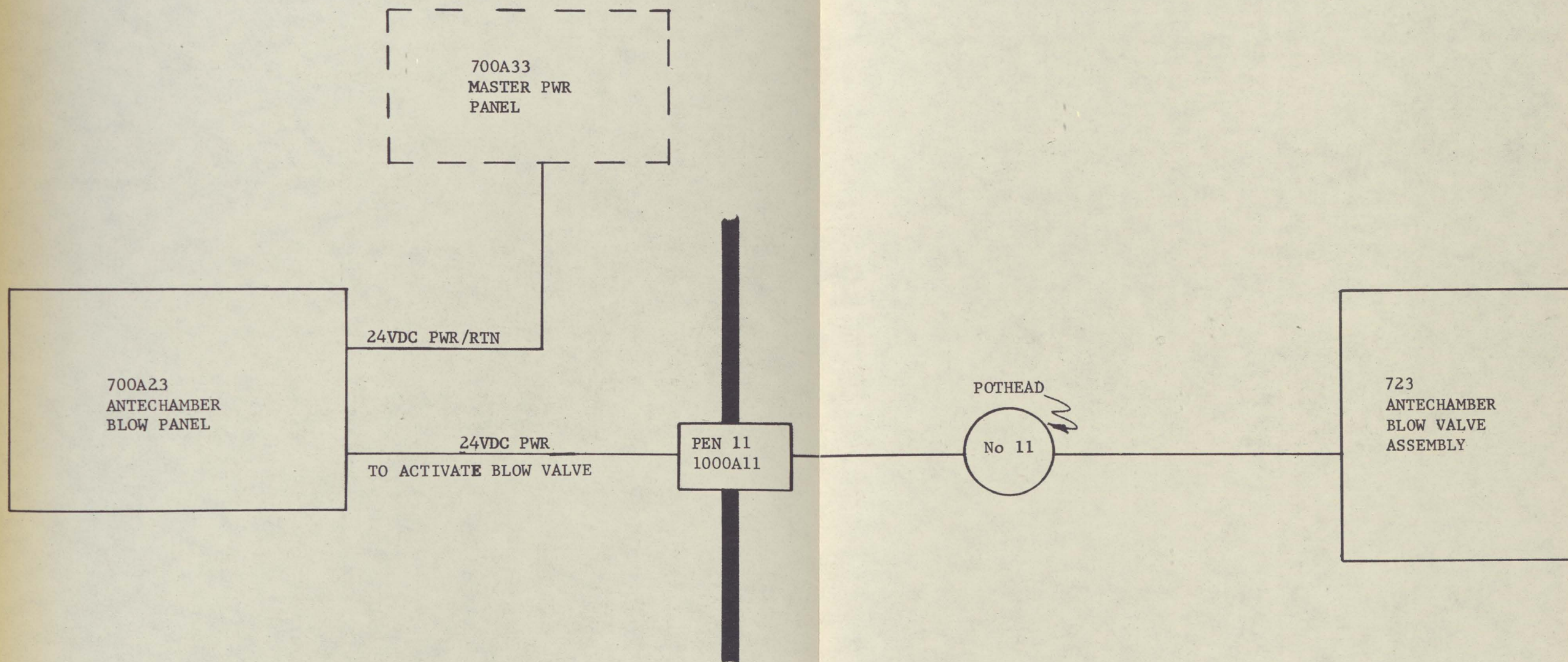

FIGURE 3-16. ANTECHAMBER BLOW SYSTEM

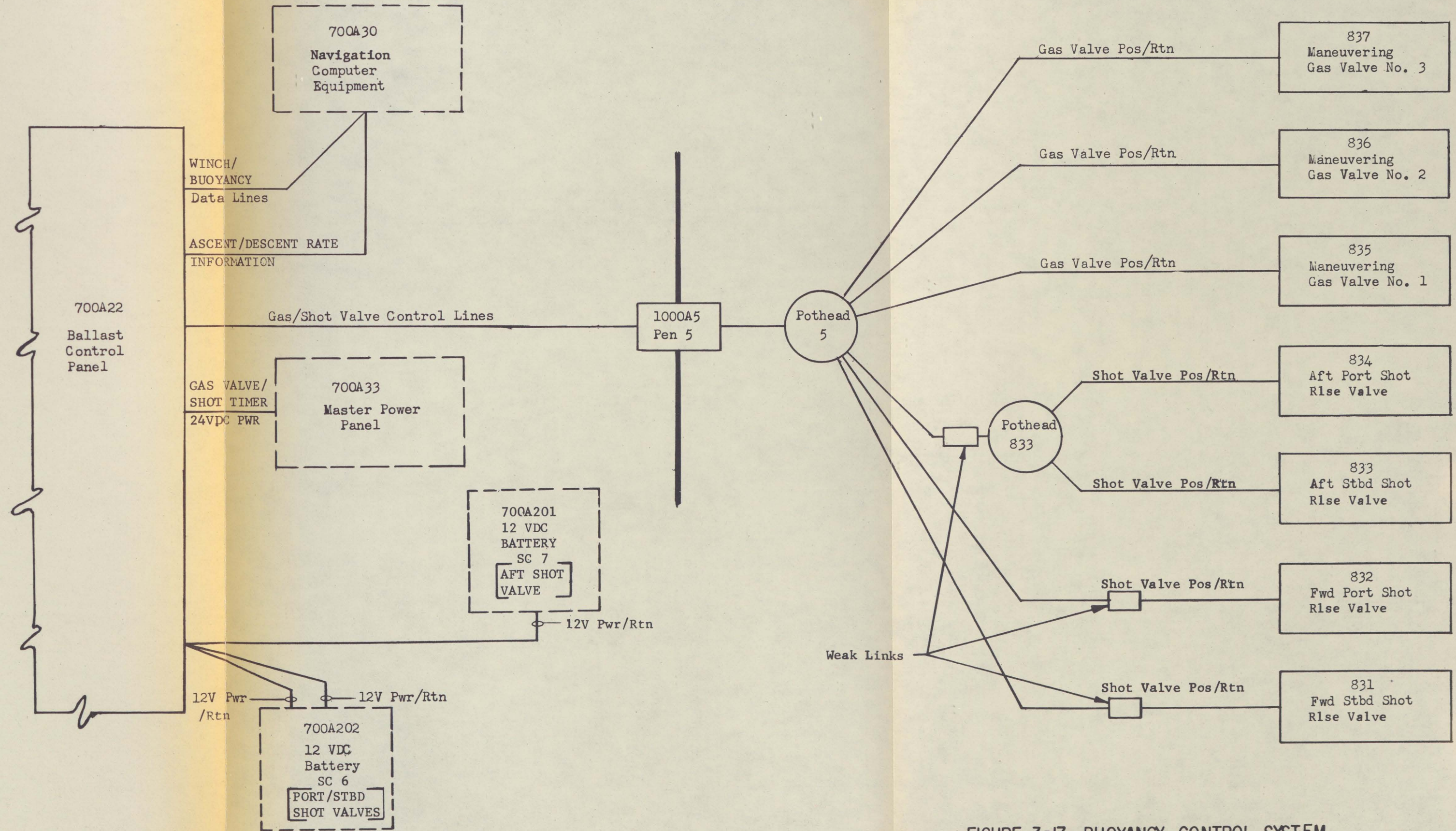

FIGURE 3-17. BUOYANCY CONTROL SYSTEM

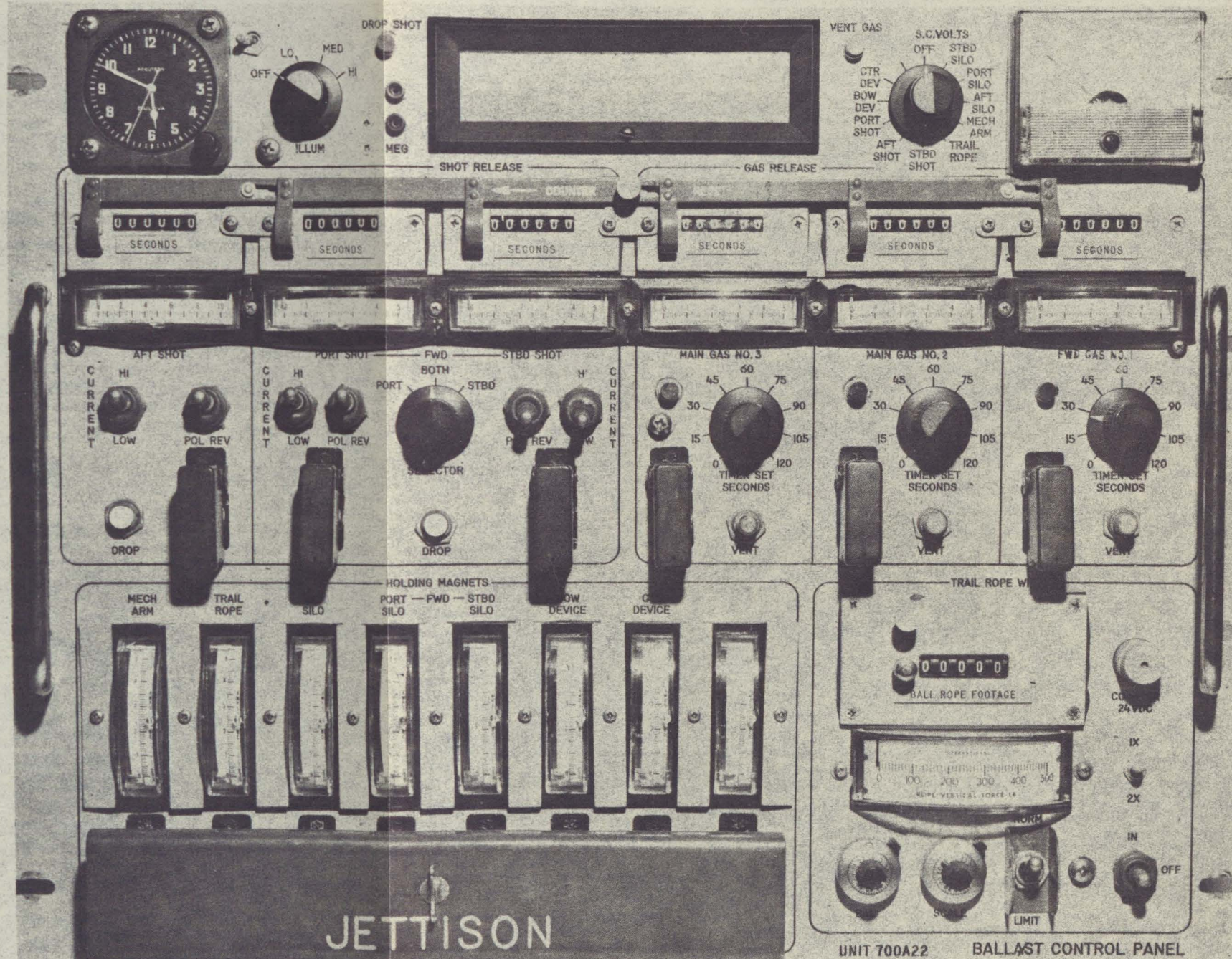

FIGURE 3-18. BALLAST CONTROL PANEL

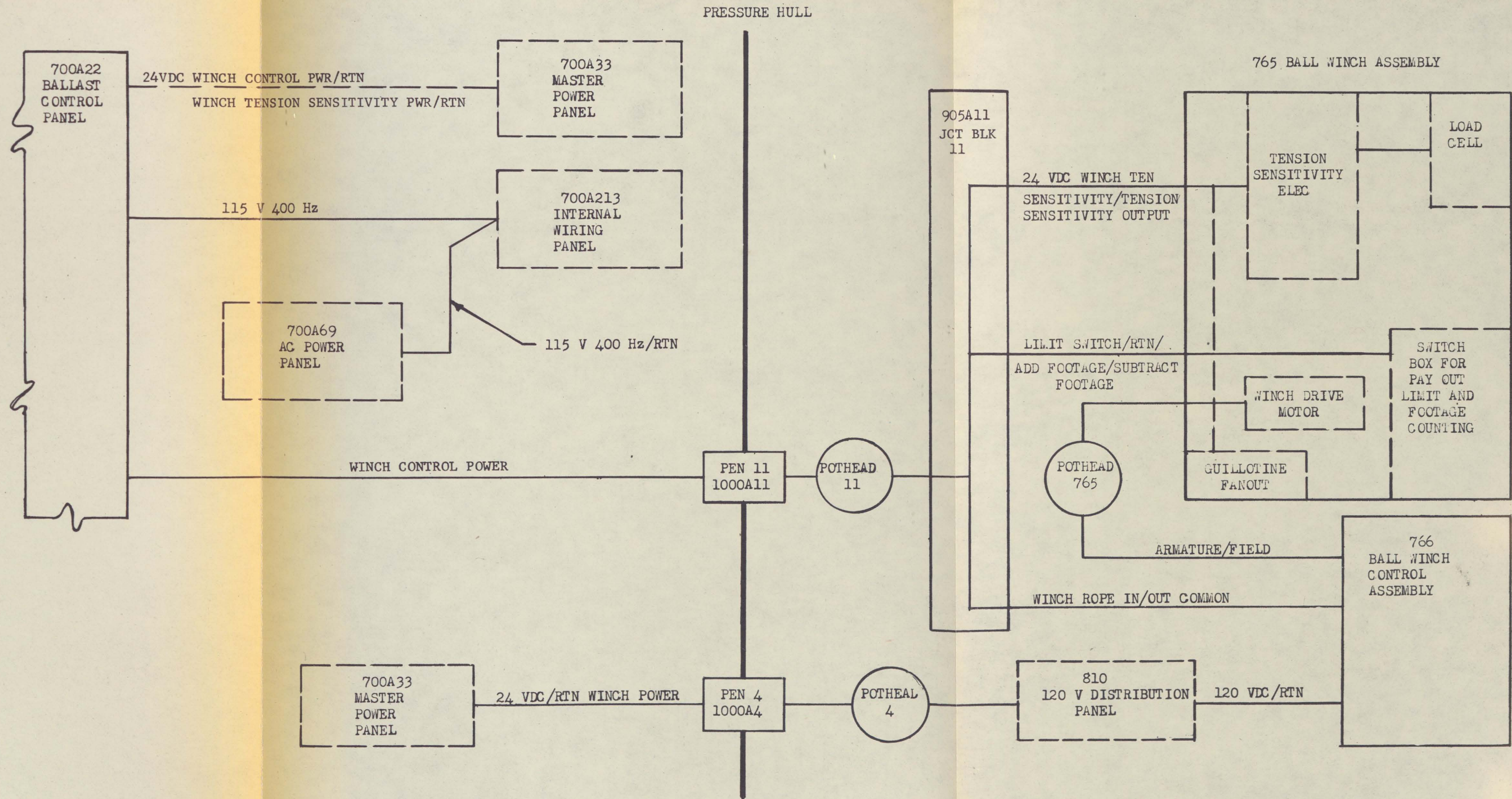

FIGURE 3-19. TRAIL BALL WINCH AND CABLE TENSION SYSTEM

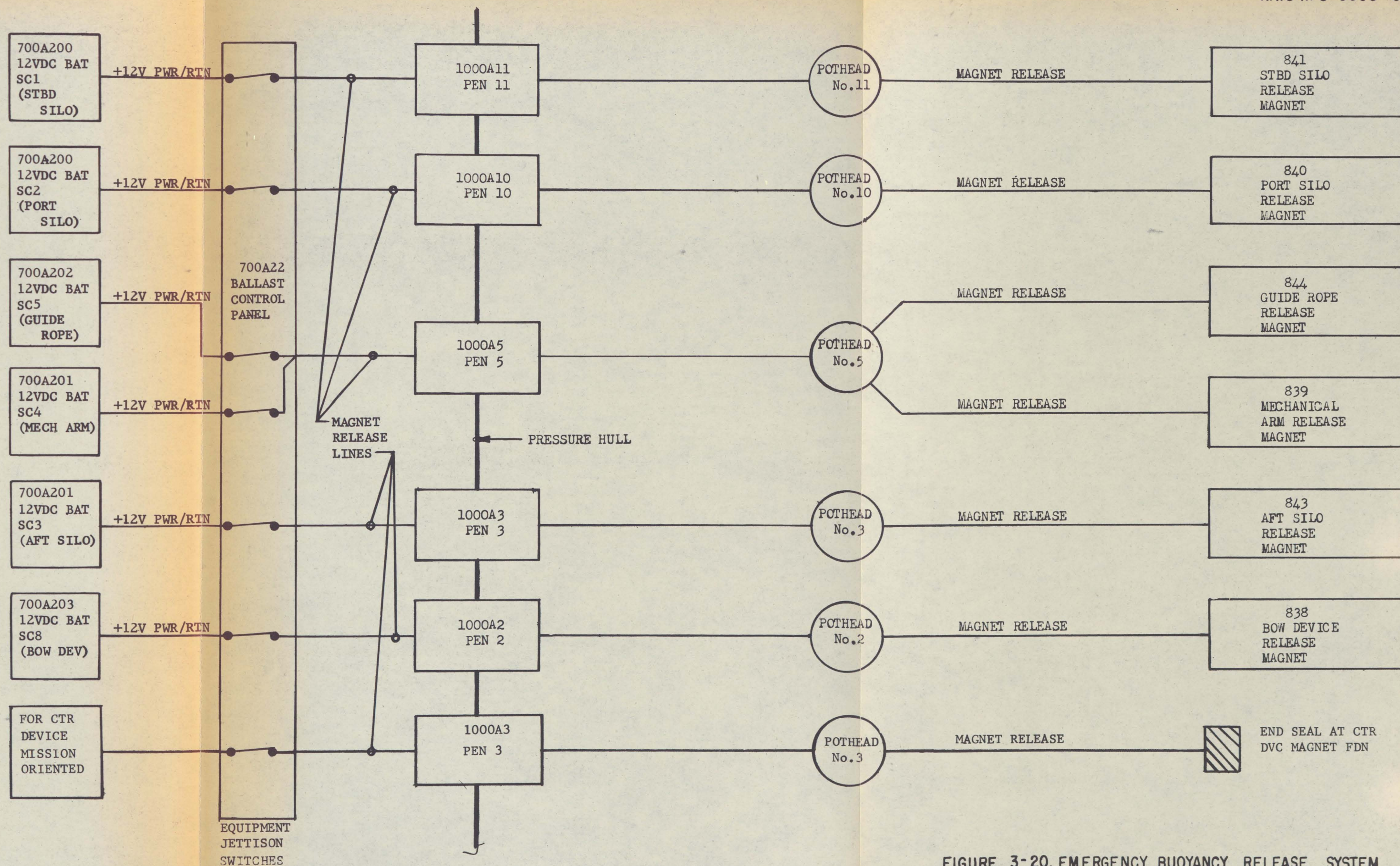

FIGURE 3-20. EMERGENCY BUOYANCY RELEASE SYSTEM



CHAPTER 4

ELECTRONICS SYSTEM

Number		Page
4-1.	Introduction	4-1
4-3.	General Description	4-1
4-9.	Navigation Computer System	4-2
4-23.	Computer Depth Transducer System	4-4
4-26.	Doppler Sonar System	4-5
4-31.	Transponder Interrogator Sonar System	4-6
4-44.	Gyrocompass and Heading Display	4-8
4-58.	Sonar System	4-11
4-70.	Fathometer	4-14
4-74.	Depth Indicator System	4-14
4-77.	Beacon Release System	4-15
4-88.	Sound Velocimeter System	4-17
4-99.	Communication System	4-18
4-111.	Camera Systems	4-20
4-130.	Pan & Tilt Control Panel (Unit 700A66)	4-23
4-135.	TV Monitors (Units 700A04, 700A09)	4-24
4-138.	Video Tape Recorder (Unit 700A103)	4-24
4-141.	70mm System	4-24
4-145.	Electronic Strobes (Units 735, 736, 750)	4-25
4-149.	Lighting Control Panel (Unit 700A15)	4-25
4-156.	Multiplex System	4-28

CHAPTER 4

ELECTRONICS SYSTEM

4-1. INTRODUCTION.

4-2. This chapter provides a detailed functional description for each of the four major subsystems comprising the Trieste II Electronic systems. The subsystems and equipment described in this chapter provide the means of locating, with respect to a set of coordinates or sonar (transponder) direction, the support ship (or other surface vehicle) and submerged objects detected by vehicle sensor systems. The vehicle's navigation subsystem is also capable of determining ship position in three axes from an initial reference point through use of the doppler sonar system, the navigation computer and the AN/SRN-9A Satellite Navigation System on the support ship. A list of drawings and publications related to this chapter is included as an appendix to this SIB, and is offered as a source of additional reference material.

4-3. GENERAL DESCRIPTION.

4-4. The electronic systems provide for continuous monitoring and indication of the vehicle's position (course and position keeping task); communications with the support ship and/or tracking boat, and remote viewing of vehicle sightings, with capabilities for permanent recording of these sightings. The electronic systems are divided into four major functional groups:

1. Navigation - the navigation computer, interfacing equipment, the navigation sonars, associated equipment and depth indicators.
2. Communication - surface radio, underwater telephone, voice recorder, tracking and emergency sonars.
3. Camera - television and 70mm still cameras, electronic strobes, and Pan and Tilt mechanisms.
4. Multiplex - internal multiplex unit and external multiplex units.

4-5. Navigation System. The navigation system provides range, bearing and velocity information on the position of the vehicle with respect to objects on the surface, submerged in, or on the bottom of the ocean. The object may be a support ship, deep ocean transponder, bottom surface, another submersible, or a fixed coordinate system.

4-6. Communication System. The communication system allows for voice communication between the vehicle and support ship when the vehicle is surfaced or submerged and provides a sonar "pinger" in the event that voice communication fails.

4-7. Camera System. The camera system provides the capability for remote viewing of the area around the vehicle. This system allows the operators to view a potential work site, to view an object on the ocean bottom in finer detail, or to observe and evaluate an operation to be undertaken. The camera system is provided with the capability to permanently record the observations.

4-8. Multiplex System. The multiplex system permits the two-way transmission of control and information signals for lighting, television camera, 70mm still camera, electronic strobe, and pan and tilt control. This line-sharing capability allows for maximum transmission of data using a minimum number of penetrator pins.

4-9. NAVIGATION COMPUTER SYSTEM.

4-10. SYSTEM DESCRIPTION. The navigation computer system (Figure 4-1) performs three specific functions: provides continuous position, heading and velocity data to the operator; can control and move the vehicle horizontally and maintain heading during any phase of the dive operation. Four information (sensor) subsystems automatically provide digital or analog data to the navigation computer and are part of the navigation computer system. The doppler sonar system provides a pulsed signal whose pulse rate is proportional to the velocity of the vehicle relative to the bottom; the transponder interrogator system provides a parallel transfer of digital data, indicating range and identification of surrounding transponders in the navigational grid; the computer depth transducer system provides a voltage signal proportional to the depth; and the gyrocompass system provides digital directional data. Figure 4-1 shows the interconnections of these units.

4-11. Three other sensor systems on the vehicle provide information for manual input to the computer: the CTFM sonar system, the Furuno depth sounder, the sound velocimeter, and the depth indicator. The computer-processed navigation is displayed, and the course is automatically plotted on the analog plotter (Unit 700A16). The vehicle sensor system providing input (automatic and manual) to the navigation computer are described later in this chapter. Additional information concerning computer-directed propulsion is provided in Chapter 3.

4-12. Coordinate Systems. The navigation computer system utilizes two coordinate systems to perform the navigation task. The first system is the local dead reckoning coordinate system which may be rotated or shifted to suit the specific needs of a dive. The dead reckoned position is a continuous extrapolation (automatically performed by the navigation computer) of vehicle position based on heading and distance traveled. The position is updated every 0.84 seconds using heading inputs from the Mark 27 gyrocompass and ground speed inputs from the doppler sonar. A second update every 3.5 minutes limits the accumulated roundoff error. Periodic resets of the dead reckoning position are necessary due to buildup of small heading and velocity inaccuracies from the gyrocompass and doppler sonar systems.

4-13. The second coordinate system is the reference coordinate system which is fixed and defined in terms of an origin, and an angle with true North. Initially, the location of the origin relative to the bottom is arbitrary but becomes defined when the navigator selects a point as the origin and an angle with true North, and then defines the locations of bottom fixed objects (such as transponders). The locations of these objects are stored in the computer memory. Once defined, the orientation of the reference coordinate system and the locations of fixed objects in the coordinate system cannot be changed during the mission without voiding all position information. The dead reckoning is referenced to the reference coordinate system by an angle with North and an origin point in the reference system. All navigation computations are displayed in the dead reckoning system coordinates.

4-14. COMPUTER.

4-15. Computer, Memory and Analog Plotter. The computer system processes information from the automatic and manual navigation sensors, outputs continuously updated navigational data, and controls the vehicle's horizontal movements when requested. The center of the system is the Mark XV computer, a general purpose micrologic digital computer. The computer system consists of the following six units:

1. Computer memory unit - (Unit 700A30A3)
2. Computer processor unit - (Unit 700A30A1)
3. Computer converter unit - (Unit 700A30A2)
4. Analog plotter panel - (Unit 700A16)
5. Computer control panel - (Unit 700A11)
6. Memory protect panel - (Unit 700A99)

4-16. The memory, processor and converter units are components of the navigation computer (Unit 700A30) located in Bay 8 of the sphere, the plotter in Bay 5, the computer control panel in Bay 7, and the memory protect panel between Bays 8 and 9.

4-17. Computer Memory Unit (Unit 700A30A3). The computer memory unit (CMU) consists of a matrix of magnetic core elements that are grouped to provide a maximum capacity of 5632 binary words, 21 bits long. This memory capacity is used for control instructions and constants used in performing navigational computations. The instructions and accompanying numerical data are inserted into the permanent memory portion of the CMU via punched tape input. The stored-program (core resident) feature of the navigation computer offers desirable system flexibility, since future changes or additions can be implemented with programming changes rather than hard-wire modifications.

4-18. Computer Processor Unit (Unit 700A30A1). The computer processor unit (CPU) is the data processing unit of the computer. It contains an arithmetic unit for the basic calculating operations, and the registers, decoding matrices

and logic elements that process instructions, maintain the proper program sequence and control the other units of the navigation computer.

4-19. Computer Converter Unit (Unit 700A30A2). The converter unit of the computer contains the analog-to-digital and digital-to-analog converters required for the various input-output interfaces of the computer. This unit also houses the main power supply for the CMU.

4-20. Computer Control Panel (Unit 700A11). The navigation computer is operated through the computer control panel (Figure 4-2). This panel provides all operating displays and controls for the computer. Displays include digital and analog presentations of quantities available in the computer, computer and operational alarms, and mode indicators which display the operation which the computer is performing. Computer controls provide for all mode switching, inputting of data, and means for instructing the computer to use data input.

4-21. Analog Plotter Panel (Unit 700A16). The analog plotter (Figure 4-3) is a device for recording information from two variables on 8 1/2-by 11-inch graph paper. The plotting pen travels along X and Y axes independently, with position and movement determined by DC analog signals from the output converters of the navigation computer. The plotter is used to display progress along the desired course. During bottom search, it is used to display search pattern progress; during inspection, it is used to display maneuvering pattern progress.

4-22. Memory Protect Panel (Unit 700A99). The memory protect panel provides a delaying factor in the event of a navigation computer power loss or significant drop in line voltage. Proper shutdown of the computer is not instantaneous and to insure that the proper shutdown sequence occurs without loss of memory-stored data, an alternate supply of power is needed for a brief period. The memory protect panel provides this power source.

4-23. COMPUTER DEPTH TRANSDUCER SYSTEM.

4-24. GENERAL. The computer depth transducer system (Figure 4-4) provides pressure depth data for display and also provides voltage input data for use by the navigation computer. This system consists of four units:

1. External pressure XDCR - (Unit 789)
2. External pressure XDCR - (Unit 792)
3. Pressure XDCR panel - (Unit 700A25)
4. Pressure XDCR power supply - (Unit 700A77)

The above pressure transducers are located in the starboard (forward) and port (aft) areas of the sail. The pressure XDCR panel (Unit 700A25) and power supply (Unit 700A77) are mounted in Bay 2 of the sphere.

4-25. SYSTEM OPERATION. The pressure transducers, XDCR No. 1 or XDCR No. 2, as selected by the XDCR SELECT switch on the pressure transducer panel (Figure 4-5), provide a scaled voltage directly proportional to the pressure depth. The voltage output of the transducer is measured and biased for the specific depth by the panel electronics. The signal is then amplified so that it is compatible with the full range of the analog converter input to the computer. The panel provides eleven depth ranges of 2500 feet each (with a 500 foot overlap) which may be selected by a rotary PRESSURE DEPTH RANGE-FEET switch on the panel. The maximum depth range selection is 20,000 feet. The pressure transducer power supply provides 28-VDC power, independently, to each of the pressure transducers.

4-26. DOPPLER SONAR SYSTEM.

4-27. GENERAL. The doppler sonar system (Figure 4-6) provides low-altitude, high-accuracy measurements of the vehicle's velocity for display and as an input to the navigation computer. The doppler sonar determines the three components of the vehicle's velocity (fore-aft, port-starboard, and up-down) and supplies them as independent pulse trains to the navigation computer (Unit 700A30) and to the doppler sonar display panel (Figure 4-7) where they are displayed. A footage counter (DISTANCE-FEET) on the display panel shows the total horizontal distance traveled, forward or aft. The doppler system consists of a main electronics panel (Unit 700A24) and a display panel (Unit 700A08) both mounted within the sphere, and a transducer unit assembly (Unit 785), mounted externally.

4-28. TRANSDUCER UNIT ASSEMBLY (Unit 785). The transducer unit assembly consists of several subassemblies including a transmitter electronics unit, an array of four transmitting and four receiving transducers, connecting cables, and an acoustical shield which are mounted on an open free-flooding frame structure. The complete transducer unit assembly, is mounted on the forward bottom of the vehicle. The transducer unit assembly provides a 600-kHz frequency through the four transmitting transducers and receives four doppler return frequencies. The transducer array is constructed so that maximum coverage is provided from port, starboard, forward, and aft signals. The return signals are fed to the electronics panel for processing.

4-29. ELECTRONICS PANEL (Unit 700A24). The electronics panel is mounted in Bay 3 of the sphere. This unit receives the four signals from the transducer array and derives doppler audio difference frequencies. The difference frequency between the forward and aft return signals is proportional to the vehicle ground velocity along the forward-aft axis. Similarly, the difference frequency between the starboard and port return signals is proportional to the vehicle ground velocity along the vehicle port-starboard axis. Vehicle deck-vertical velocity is proportional to the difference between the port-starboard sum frequency and twice the transmitted frequency. The polarity of each velocity component is determined by sensing the phase of the respective difference frequencies. From these doppler frequencies, three individual-axis pulse trains are derived, whose pulse rate is proportional to the three velocity components. The three sets of pulse trains are then sent to the computer as input for dead-reckoning navigation. The pulse train data is also used within the electronics panel for producing the voltages necessary to drive the velocity meters and the DISTANCE-FEET counter on the display panel.

4-30. DISPLAY PANEL (Unit 700A08). The display panel (Figure 4-7) is mounted in Bay 2 of the sphere. The panel receives the frequencies processed by the electronics panel and displays them as the three components of the vehicle's velocity. The footage counter on the display panel also indicates total distance traveled, forward or aft.

4-31. TRANSPONDER INTERROGATOR SONAR SYSTEM.

4-32. GENERAL. The navigational transponder interrogator sonar system (TIS) (Figure 4-8) provides the navigation computer with transponder identification and range information relative to a navigation grid. A surface ship or submersible vehicle is used to deploy a series of transponders in a grid pattern within the search area. When the transponders are deployed and the navigation grid is established, the vehicle is capable of highly accurate navigation within the grid.

4-33. The transponders transmit a pulsed signal on assigned frequencies when activated by an interrogation signal from the omnidirectional sonar unit on the vehicle. The returns are received by the sonar unit and sent to the transponder interrogator processor (Unit 700A32) and display panel (Unit 700A29). These units (Figure 4-9) count elapsed time to establish the range to the closest transponder and identify the transponder. Range and transponder ID information is sent to the navigation computer and the vehicle's position is automatically plotted on the X-Y Plotter. In the manual mode, the information may be read out on a visual display. The visual display information can be used by the operator to hand plot the location of the vehicle within the transponder grid. The TIS system consists of the transponder interrogator processor (Unit 700A32), the display panel (Unit 700A29), two omnidirectional transducers (Unit 767A1-top and Unit 767A2-bottom) and the TIS electronics bottle assembly (Unit 768).

4-34. TRANSDUCERS. Each of the two transducers provides dual transmit and receive function through a 360 degree horizontal arc. Switch selection on the display panel permits the proper transducer to be switched into the transmit/receive signal path. The topside transducer (Unit 767A1) is located at the top of the extendable mast at the aft end of the sail. The bottom transducer (Unit 767A2) is located between the aft shot tub and the trail ball winch, slightly port of the centerline. The ceramic-ring transducer element is contained in a self-compensated cylindrical housing.

4-35. TIS ELECTRONICS BOTTLE (Unit 768). The electronics bottle is a pressure-tight enclosure located in the forward port area of the sail. The bottle contains the sonar transmitter and receiver. A transponder start-command from the transponder interrogator processor causes the transmitter to emit a 4 millisecond pulse. The $7 \text{ kHz} \pm 25 \text{ Hz}$ interrogate pulse is transmitted at a maximum power output of 5 watts and activates transponders within a useable range of 29,000 feet. The receiver accepts the first three return signals through the transducer - representing the three nearest transponders - amplifies the return signals and passes them on to the transponder interrogator processor for processing. A maximum of ten transponders can be used in the net; each activated transponder replies on one of ten assigned frequencies ranging from 12.5 kHz to 17 kHz in increments of 500 Hz.

4-36. TIS PROCESSOR (Unit 700A32). The transponder interrogator processor is contained in an aluminum cabinet 10-inches high, 19-inches wide and 12 1/2-inches deep and is located in Bay 8 of the sphere. The processor consists of the electronics necessary to extract channel identification from the frequency of the transponder return signals, and to determine range information from the measurement of the interrogation return signal interval. This information is then provided to the display panel and to the navigation computer.

4-37. TIS DISPLAY PANEL. The display panel is located in Bay 7 of the sphere. It contains the controls and displays necessary to provide a manual navigation mode. The display panel provides transponder channel/range selection switches that allow the operator to select the transponder return signals to be processed, and to vary the range from which return signals will be accepted. The display panel also provides controls connecting it to the navigation computer, which put the TIS largely under computer control. The panel also provides voltage conversion circuits which convert the battery source voltage to required equipment power supply levels.

4-38. TIS OPERATING MODES. The transponder interrogator sonar system functions automatically or manually in any of four operating modes. A fifth mode is provided for test purposes. The operating modes are described below and the display panel is illustrated in Figure 4-9.

4-39. Computer Automatic Mode. After a start-pulse is initiated automatically by the computer, the TIS system provides transponder-return signal information to the navigational computer. The sonar transmits an interrogating signal, receives return signals from the three closest transponders, and sends the data to the computer. As the information from each of these interrogation cycles is received by the computer, a data acknowledge signal from the computer initiates the next cycle.

4-40. Computer Single Mode. This mode is similar to the computer automatic mode except that each succeeding interrogation cycle must be initiated with a start-pulse by manually depressing the START switch on the panel.

4-41. Semiautomatic Mode. In this mode of operation, communication with the computer is inhibited and the transponder information is presented on the display panel. Each interrogation cycle is internally initiated at an operator-selectable rate of either one per minute or two per minute. All three return signals are displayed at one time on the TIS DISPLAY.

4-42. Manual Single Mode. In this mode, as in the semiautomatic mode, communication with the computer is inhibited and the transponder information is presented on the display panel. Each interrogation cycle is initiated by a start-pulse. The operator must press the START button to sequence the equipment and initiate a new interrogation cycle.

4-43. Test Mode. The computer and transmit signals are isolated from the processor in this mode, and a simulated transponder return signal of 20,000 feet is used to test the processor and display panel. In this test mode, the processor will still receive return signals from the electronics bottle.

4-44. GYROCOMPASS AND HEADING DISPLAY.

4-45. GENERAL. The gyrocompass and heading display system (Figure 4-10) generates precise heading information which allows the vehicle to accurately navigate along the ocean floor. The information generated is converted into synchro data for visual display, and into digital form suitable for computer input. The gyrocompass (Gyro) and heading display system consists of the gyrocompass control panel (Unit 700A54) and the gyrocompass repeater and indicator panel (Unit 700A07).

4-46. GYROCOMPASS CONTROL PANEL. The gyrocompass control panel (Unit 700A54) (Figure 4-11) consists of two major subassemblies, the gyrocompass master unit and the electronic control assembly. The control panel is located in Bay 4.

4-47. Gyrocompass Master Unit. The gyrocompass master unit contains the compass element of the system. The two basic parts of the master unit are the binnacle and base. The binnacle is fluid filled, and shock mounted in the base of the unit. The shock mounts are positioned to act through the center of gravity of the binnacle. The base is a casting which is fixed to the deck by four bolts, with plus or minus 5 degrees of freedom in azimuth, to permit accurate alignment with the vehicle. For protection of the unit during docking, the compass element can be caged by depressing a button on the top of the unit.

4-48. The main component of the compass element is the gyrosphere, which continuously seeks and aligns itself with the meridian, pointing to true North. The properties of the gyroscope in combination with the rotation of the Earth and the effect of gravity produce this result.

4-49. The master unit is mounted alongside the electronic control assembly in Bay 4. The master unit and the electronic control assembly are interconnected by a single electronic cable. The gyro control panel is provided with a panel cutout for viewing the compass card display on the master unit. The master unit receives 115-volt, 400-Hz and 24-VDC operating voltages from the electronic control assembly.

4-50. Electronic Control Assembly. The electronic control assembly is a watertight, deck-mounted unit which houses the control panel, follow-up servo amplifier, alarm circuitry, power supply, latitude control circuitry, and the gyrocompass control functions. The servo amplifier printed-circuit board and the power supply section (except the power transistors) are removable for maintenance. All other internal components are easily accessible by removal of the chassis and panel combination from the front. Plug-in connectors on the rear of the panel interconnect cabling to vehicle power, the gyrocompass master unit, data transmission and failure-alarm circuits. The data transmission is sent to the gyrocompass repeater and indicator panel in synchro form for visual display, for synchro transmission to the propulsion control (Unit 700A10), and for synchro-to-digital conversion as input to the navigation computer (Unit 700A30).

4-51. The servo amplifier is an integral part of the follow-up system used for the gyrocompass system. It provides stabilization and quick response to the overall follow-up system. It uses other signal sources to aid in leveling the gyrocompass, or to slew it in azimuth during starting. The power supply section of the electronic control assembly converts the 24-VDC vehicle power to 115-volt, 400-Hz power.

4-52. The latitude corrector circuit is used to correct for latitude error, a result of the effect of the vertical torque generated by the gyro damping weight and the tilt of the gyro axle. The magnitude of the error increases with increasing latitude and it is compensated for by a voltage, controlled by a panel mounted latitude potentiometer.

4-53. The alarm circuitry monitors the follow-up system and the supply power to the servo amplifier. In the event of a follow-up system failure or the loss of power to the servo amplifier, the alarm circuitry provides a visual indication on the gyrocompass control panel. The control panel is mounted on the gyrocompass control panel (Unit 700A54) in Bay 4. The panel controls and their functions are listed in Table 4-1. The electronic control assembly receives its supply voltage from the 24-VDC port power panel (Unit 700A34), and 400-Hz synchro reference voltage from the AC power panel (Unit 700A69).

Table 4-1. Gyrocompass Control Panel - Controls and Indicators

CONTROL/INDICATOR	FUNCTION
RPTR Switch	Controls the internally generated power for operating external repeater equipment.
N-S Switch	Used in conjunction with the LATITUDE CORRECTOR to select for North or South latitude correction.
CAGED UNCAGED Switch	Cages the compass element for protection during docking.
CAGED Indicator	Illuminates only when the gyro is caged and the equipment is on.
LEVEL Meter	Provides an indication of the tilt of the gyro spin axis. Used primarily during starting of the compass to assure the gyro is started level. Its sensitivity is approximately 2 minutes per division.
FOLLOW-UP ALARM Indicator	Illuminates if there is any failure in the follow-up system or in the power to the servo amplifier.

Table 4-1. Gyrocompass Control Panel - Controls and Indicators (Continued)

CONTROL/INDICATOR	FUNCTION
POWER Indicator	Illuminates when external power is applied and the internal power supply is supplying power to the compass and control circuits.
DIMMER Control	Rheostat, controlling the brightness of the compass card illumination.
TILT/AZIMUTH Switch	Provides two functions. When slewing the compass, it controls the direction of rotation of the compass element. It also provides a signal to level or to increase the tilt of the gyro spin axis.
LATITUDE Corrector Control	Provides a latitude correction signal.
MODE SELECTOR Switch	<p>Selects the various circuits used to control operation of the compass.</p> <p><u>SLEW position</u> - all compass circuits are energized except the gyro wheel and repeater excitation. The compass is slewed to vehicle's heading prior to starting the gyro using the TILT/AZIMUTH switch.</p> <p><u>START position</u> - all circuits are energized and the gyro wheel is brought up to speed. Repeater circuits remain de-energized until an internal relay is automatically actuated after the gyro comes up to speed.</p> <p><u>RUN position</u> - the TILT/AZIMUTH switch is disconnected so the gyro cannot be accidentally tilted during normal operation.</p> <p><u>MANUAL LEVEL</u> - tilting or leveling of the gyro is done using the TILT/AZIMUTH switch.</p> <p><u>AUTO LEVEL</u> - gyro is automatically brought to an almost level position and held there. This mode used only if gyro has dumped or level meter indicates full scale.</p>
1 AMP RPTR fuse	Protects internal power supply when used with external repeaters.
1 AMP AC fuse	Protects basic 120-VAC internally generated power.
8 AMP DC fuse	Protects internal power supply of the electronic control assembly.

4-54. GYROCOMPASS REPEATER AND INDICATOR PANEL. The gyrocompass repeater and indicator panel (Unit 700A07) (Figure 4-12) consists of three subsystems, the gyro repeater, directional gyro, and the altimeter. The gyro repeater and indicator panel is located in Bay 2. The indicator panel receives 115-volt, 400-Hz and 24-VDC supply voltages from the AC power panel (Unit 700A69) and the port power panel (Unit 700A34) respectively.

4-55. Gyro Repeater. The gyro repeater is a synchro repeater which receives vehicle heading information in the form of synchro data and displays this information on the vehicle's heading card located on the repeater panel. The repeater panel also consists of a repeating synchro for re-transmission of heading data to the propulsion control panel, a gray-code brush-type code-wheel synchro-to-digital converter for transmission to the navigation computer, a POWER ON/off switch, power ON indicators (AC and DC), fuses for the AC and DC power inputs and spare fuses for the AC and DC power inputs.

4-56. Directional Gyro. In addition to the gyrocompass system, a directional gyro has been added as a backup heading indicator. The backup unit consists of a free gyroscope with a leveling system to control precession about the horizontal axis, and force the gyro spin axis to remain level inside the case. The sole output of the unit is a visual display of vehicle heading. Since this type of gyroscope drifts, the directional gyro must be periodically slewed to agree with the gyrocompass system or to an external reference when on the surface. The directional gyro is a self-contained unit mounted on the left-hand side of the indicator panel.

4-57. Altimeter. The altimeter is mounted in the center of the indicator panel and is used to monitor the internal pressure within the sphere. Observation of the internal pressure and percent O₂ and CO₂ on the monitor panel (Unit 700A215) provides information which enables the operator to control the environmental conditions in the sphere. The altimeter is set at zero at the start of the dive and is checked periodically during the dive to monitor the pressure inside the sphere.

4-58. SONAR SYSTEM.

4-59. GENERAL. The sonar system consists of the continuous transmission frequency modulated (CTFM) scanning and navigation sonar system and the Furuno fathometer. These systems are used primarily to sense bottom conditions and to locate objects during the search phase of the dive.

4-60. CTFM SONAR SYSTEM. The CTFM sonar system (Figure 4-13) provides a means of sensing obstructions and determining range and bearing to markers or objects of interest. The system consists of:

1. CTFM Display - (Unit 700A17)
2. CTFM Analyzer - (Unit 700A18)
3. 5 Amp converter - (Unit 700A19)

4. CTFM Transducer and training assembly (top) - (Unit 741)
5. CTFM Transducer and training assembly (bottom) - (Unit 742)
6. CTFM Switch Bottle - (Unit 743)
7. CTFM Test transducer No. 1 - (Unit 786)
8. CTFM Test transducer No. 2 - (Unit 787)

4-61. The CTFM system installed on the vehicle is a AMETEK Straza Model 500, which has been modified to use a top and a bottom transducer assembly. The modification consisted of adding an external CTFM switch bottle and a new transducer and training mechanism. The receiver section has a pre-amp in the outboard hydrophone rather than within the inboard electronics. The scan limits were increased to ± 225 degrees and an external switch was added to the analyzer unit to activate the external switch bottle. Wiring modifications were made in the analyzer unit to provide for using the test transducers through internal wiring rather than making connections to the front of the unit.

4-62. The CTFM system has a range from 10 to 1500 yards and can operate in a sonar, transponder interrogate, transponder receive, and marker receive modes. In the sonar mode of operation, a linearly decreasing frequency from 87 kHz to 72 kHz is transmitted and received. The transponder mode of operation uses the sonar signal to interrogate the transponder; while the transponder response is received in the 55 kHz to 40 kHz band. Marker signals are received at 37 kHz when the marker mode is used. The system provides audio and visual displays. The individual units comprising the system are described below.

4-63. CTFM Display Unit (Unit 700A17). The CTFM display (Figure 4-14) is a rack-mounted unit located in the center of Bay 3. The display consists of two major pieces of equipment, the display unit and the sonar unit. The display unit is located on the left half of the rack and the sonar unit on the right.

1. DISPLAY UNIT. The display unit contains a cathode ray tube (CRT) which provides a visual bearing and range display of analyzed target return signals. The display unit also contains the servo subunit and the deflection subunit.

- a. Servo Subunit. The servo subunit converts the angular position information received from the training mechanism into deflection signals for proper orientation of the trace on the CRT.

- b. Deflection Subunit. The deflection subunit generates the CRT display sweep and provides deflection and position of the display trace. The subunit also provides video amplification for signals received from the analyzer unit.

2. SONAR UNIT. The sonar unit contains the frequency modulated oscillator (FMO), the power amplifier and the receiver.

- a. Frequency Modulated Oscillator. The FMO generates the FM signal which is then amplified for transmission. The FM signal is also used for comparison with the received signal to determine the range.

b. Power Amplifier. The power amplifier amplifies the FMO output signal to the level required to drive the projector.

c. Receiver. The receiver compares the frequency of the FMO output signal and the frequency of the target and transponder or marker signal received by the hydrophone to provide a difference frequency. The difference frequency is amplified to a sufficient level for aural listening and driving the analyzer.

4-64. CTFM Analyzer Unit. The CTFM Analyzer Unit (Figure 4-15) is located in the middle of Bay 3. The unit consists of the filter bank, the timing generator, and the test instrumentation.

1. FILTER BANK. The filter bank converts the difference frequency from the receiver into discrete range increments synchronized with the display trace on the CRT.

2. TIMING GENERATOR. The timing generator establishes the sampling period for the analyzer, generates the range marks of the display trace and pre-amplifies the video signal.

3. TEST INSTRUMENTATION. The test instrumentation provides a means for the operator to evaluate system performance.

4-65. CTFM 5-Ampere DC-DC Converter. The 5-ampere converter provides DC power to the analyzer unit. The analyzer unit operates on 28 VDC and 115 volts, 60 Hz and the converter transforms the 24-VDC sphere power to 28-VDC constant voltage. The converter is located in the back of Bay 3.

4-66. CTFM Switch Bottle. The CTFM switch bottle allows the sonar system to use one of two transducer and training assembly mechanisms. The switch bottle is operated by a switch on the analyzer unit which energizes relays in the bottle. The relays transfer the signals to either the top or the bottom transducer assembly.

4-67. CTFM Transducer and Training Assembly (Top). The top transducer and training assembly mechanism is located on the top, forward part of the sail.

1. TRAINING MECHANISM. The training mechanism provides the drive for rotation of the transducer assembly. Display trace positioning signals are generated by a synchro control transmitter located in this unit.

2. TRANSDUCER ASSEMBLY. The transducer assembly contains the projector and hydrophone. The projector converts the electrical drive signal from the power amplifier into ultrasonic waves, which are transmitted into the water. The hydrophone converts the ultrasonic waves received from sonar targets into electrical signals for the receiver.

4-68. CTFM Transducer and Training Assembly (Bottom). The bottom transducer and training assembly is identical to the top assembly except that it is located on the bottom, forward of the sphere.

4-69. CTFM Test Transducers No. 1 and No. 2. The test transducers are dual purpose projector/hydrophone units used in conjunction with the test instrumentation for calibration and testing of the sonar system. Transducer No. 1 is located on the top of the sail on the port side. Transducer No. 2 is located on the bottom, forward and inboard of the port skeg.

4-70. FATHOMETER.

4-71. GENERAL. The vehicle is equipped with a Furuno, Model FM-22E fathometer. This depth sounder system (Figure 4-16) consists of an internal electronics and display unit and an external transducer and is used to measure the altitude of the vehicle when within 2400 feet of the bottom.

4-72. Internal Electronics and Display Unit (Unit 700A21). The internal electronics and display (Figure 4-17) is located at the top of Bay 3. This unit consists of a chart recorder and the electronics necessary to operate the transducer. The chart recorder has eight depth ranges to provide increased accuracy as the vehicle approaches the bottom. The recorder also has a varying chart speed which permits easier reading of vehicle altitude, approaching the bottom. The electronics converts 24 VDC from the master power panel (Unit 700A33) into electrical pulses which are transmitted to the transducer (Unit 755), converted into acoustic pulses and transmitted into the water. The echos reflected from the bottom are received by the transducer, converted into electrical pulses and transmitted back to the electronics of the display unit. The time interval between transmission of the sound pulses and the reception of its echo is measured, and by calibrating the chart to an average speed of sound in seawater, the resulting altitude of the vehicle is displayed on the chart recorder.

4-73. External Transducer (Unit 755). The external transducer is located just aft of the sphere on the port side. The transducer is an Edo Western, Model 311 high-pressure transducer. This is a barium titanate transducer with a resonant frequency of 50 kHz. The function of the transducer is to convert electrical signals into acoustic signals and acoustic signals into electrical signals.

4-74. DEPTH INDICATOR SYSTEM.

4-75. GENERAL. The depth indicator system (Figure 4-18) generates a signal which is displayed on the depth indicator panel. The display consists of a depth gage showing the depth information sensed from an external pressure transducer.

4-76. DEPTH INDICATOR PANEL. The depth indicator panel (Figure 4-19) consists of a Hydro Products, Model 402 depth deck module. The Model 402 consists of a depth gage capable of indication to 20,000 feet maximum. The depth module receives the signal from the depth indicator transducer and displays the signal on the depth gage. The depth indicator monitor is located in the General Panel (Unit 700A205), Bay 5. The Model 402 is externally powered by a 24-VDC supply voltage from the starboard power panel (Unit 700A27) located in Bay 1. The external pressure transducer installed is a Hydro Products Company Model 404 depth sensor (Unit 788). The depth information is

obtained through the use of a Bourdon tube as a pressure element. The Bourdon tube is coupled to a wiper moving linearly across a precision wire-wound potentiometer. The electrical signal is sent to the depth deck module. The depth sensor housing is constructed of stainless steel, and is mounted in the sail, and port of the access trunk. The depth sensor is powered externally from a 5-VDC power source in the depth deck module.

4-77. BEACON RELEASE SYSTEM.

4-78. GENERAL. The beacon release system (homing transponder set) (Figure 4-20) allows the vehicle to set up its own navigational grid by releasing from 1 to 4 deep ocean transponders to use with the TIS system. The beacon release system consists of the following subunits:

1. General panel (beacon release panel) - (Unit 700A205)
2. Starboard power panel - 24-VDC - (Unit 700A27)
3. 24-VDC Distribution panel - (Unit 804)
4. Junction block No. 3 - (Unit 905A3)
5. Beacon release relay bottle - (Unit 906)
6. Transponder release assembly No. 1 - (Unit 907)
7. Transponder release assembly No. 2 - (Unit 908)
8. Transponder release assembly No. 3 - (Unit 909)
9. Transponder release assembly No. 4 - (Unit 910)

4-79. BEACON CONTROL PANEL. The beacon control panel (Figure 4-21) is a sub-assembly of the general panel (Unit 700A205) in Bay 1. The beacon control panel is used for selection and release of any one of four transponders installed on the vehicle.

4-80. The beacon control panel consists of two switches, a BEACON SELECT, and a beacon RELEASE switch. The BEACON SELECT switch is a five position switch with an OFF position and four positions for the selection of one of four transponders. The beacon RELEASE switch is a momentary action toggle switch used to release the selected transponder. The beacon control panel receives its 24-VDC supply voltage from the starboard power panel (Unit 700A27).

4-81. JUNCTION BLOCK NO. 3. The transponder control and release signals are sent from the beacon control panel to junction block No. 3 (Unit 905A3) for outboard distribution to the beacon release relay bottle. Junction block No. 2 is a polyurethane-encapsulated terminal strip which is located outboard in the sail and portside of the access trunk.

4-82. BEACON RELEASE RELAY BOTTLE. The beacon release relay bottle (Unit 906) is a hard shell pressure proof enclosure, which contains four electrical relays. The relays are used as electromechanical switches to control power to the release mechanisms of the beacon release assemblies. These relays are required to control the large currents needed to operate the release mechanisms of the transponder release assemblies. The beacon release bottle is powered from the 24-VDC distribution panel (Unit 804).

4-83. TRANSPONDER RELEASE ASSEMBLY. There are four transponder release assemblies installed on the vehicle (Units 907, 908, 909, 910). The assemblies are located outboard, topside, near frame four and are mounted in pairs on the port and starboard sides. Each transponder release assembly contains: a transponder launching canister, a release mechanism, a launching canister foundation assembly and a homing transponder assembly (when loaded).

4-84. Transponder Launching Canister. The launching canister is an aluminum alloy tubular structure, which is open at one end. The enclosed end of the canister is used for mounting the electrical connector and the release mechanism. The transponder assembly is retained inside the launching canister by the release mechanism until the preselected deployment sight is reached. Upon reaching the selected location, the transponder assemblies are gravity launched from the canisters by activating the beacon release switch on the inboard beacon control panel.

4-85. Release Mechanism. The release mechanism consists of a solenoid-controlled hook or latch which is mounted to a base plate and housed in a protective covering. The release mechanism is mounted inside the launching canister at the enclosed end.

4-86. In operation, the release mechanism is normally de-energized. In this position the homing transponder assembly is securely held in the launching canister. When the homing transponder is launched by the beacon release switch, the solenoid is energized and the release mechanism releases the homing transponder from the launching canister.

4-87. Homing Transponder Assembly. The transponder assembly is an electronic homing device used for navigational purposes and consists of three major sub-assemblies. Two of these subassemblies, the float and transducer assembly, and the electronic assembly are interconnected by the third, the electrical cable assembly. Deployment and operation of the homing transponder is described below:

1. DEPLOYMENT. The homing transponder is gravity launched from the canister. Once clear of the canister, the transponder rotates vertically 180 degrees, due to the weight difference between the two ends of the unit. The two floats of the transponder assembly are then extended upward to a fixed-arm position and the electronic unit slowly descends to the ocean floor and serves as an anchor for the entire assembly. An arming switch inside the electronic assembly of the device initiates application of operating voltage to transponder circuitry. Simultaneous with the arming switch activation, a 10-minute timing period commences, which when completed, causes the float and transducer assembly to be released from the electronic assembly and ascend.

An electrical cable assembly, connected between the two separate assemblies, provides an optimum operational distance of approximately 8 feet between the two units.

2. TRANSPONDER OPERATION. With the homing transponder deployed on the ocean floor, the vehicle transmits a 7-kHz interrogator signal. The interrogate signal is received by the transducer and is relayed to the electronic assembly to trigger a reply signal of preselected frequency. The reply signal is then transmitted back through the seawater by the transducer and received by the vehicle. With the three homing transponders set to different reply frequencies, the vehicle is able to determine its precise location on the ocean floor in reference to the locations of the three transponders.

3. TRANSPONDER POWER. The homing transponder assemblies are internally powered by a 24-VDC power source. The transponder assembly has a reliable operating life expectancy of either 720 hours or 100,000 interrogations.

4-88. SOUND VELOCIMETER SYSTEM.

4-89. GENERAL. The sound velocimeter system (Figure 4-22) consists of a deep sea velocimeter (Unit 770) Nus, Model 1030-005, AC and DC power panels, and an electronic counter display unit. This system is used to determine the precise speed of sound in water. In normal operation the speed of sound in sea water is dependent upon the environmental conditions encountered, i.e., temperature, pressure, and salinity. A precise knowledge of the propagation velocity is required for accurate navigational computations.

4-90. SOUND VELOCIMETER.

4-91. Description. The velocimeter is capable of measuring the speed of sound to an accuracy of one part in ten thousand. Silicon semiconductor components are used to ensure stable operation and storage over a wide range of temperatures. Lead zirconate/lead titanate piezoelectric ceramic is used in the transducer, resulting in further improvement in the temperature stability of the instrument and at the same time minimizing the transducers' susceptibility to repeated pressure cycling.

4-92. Installation. The velocimeter is mounted outboard, portside, inside the sail, underneath the step, and is housed in a stainless steel, pressure-proof housing that is operable to maximum ocean depths. The exposed metallic components are fabricated from type 316 stainless steel. The steel is passivated to further enhance its corrosion resistant properties in seawater.

4-93. Operation. The velocimeter provides a continuous measurement of the sound velocity in a form suitable for digital analysis. The data handling problem is further simplified since the frequency output of the unit is a linear function of sound velocity, within one part in ten thousand, over a wide range of environmental conditions. During operation, a pulse of acoustic energy is transmitted through the water, received, amplified and used to generate another pulse of

energy. The repetition or sing-around frequency of this regenerative action is dependent upon the transmit time of the signal pulse in seawater and is therefore a measure of the propagation velocity.

4-94. Power. The sound velocimeter requires an external 24-VDC power source. The 24-VDC power is supplied from the starboard power panel (Unit 700A27), which is located in Bay 1.

4-95. SOUND VELOCIMETER DISPLAY.

4-96. Description. The sound velocimeter display panel (Unit 700A102), Figure 4-23, is a self-contained electronic counter package. The unit is used to receive and display the signal sent from the sound velocimeter. The electronic counter, a Hewlett Packard, Model 5321B, is a subassembly of the monitor panel, which is located in Bay 7 of the sphere.

4-97. Operation. The velocimeter transmits a square-wave signal which changes linearly and in proportion to the propagation velocity (sing-around frequency) of sound in water. The signal is received by the counter and is digitally displayed as a direct indication of the propagation velocity.

4-98. Power. The display receives its supply voltage from the 115-VAC power panel (Unit 700A60) which is located in Bay 7 of the sphere.

4-99. COMMUNICATION SYSTEM.

4-100. GENERAL. The communications system (Figure 4-25) consists of several modes of communication between the vehicle and the support ship. A communications panel in the sphere contains equipment and control for underwater telephone, sound-powered (hard-wire) telephone, vhf radio and a tape recorder. The communication system also includes the emergency/tracking pinger and the vehicle transponder.

4-101. COMMUNICATIONS PANEL (Unit 700A37). The Westinghouse, Model 400AXT communications panel (Figure 4-25) provides complete control of vehicle communications from a single panel in the sphere. Individual or simultaneous transmission and reception over acoustic, radio, and wire paths may be selected. The front panel provides all controls necessary for vehicle-to-support ship communications in the three modes.

4-102. UNDERWATER TELEPHONE. The underwater telephone is the vehicle's primary mode of communication while submerged. It uses single-sideband suppressed carrier type modulation (8.0875 - 11.088 kHz) which is crystal controlled at a frequency of 8.0875 kHz. Low-pass and band-pass filters are used with a balanced modulator to pass the upper sideband, while rejecting all other signals.

4-103. Transducers. Two transducers (Units 720 and 721) are available for underwater radiation of the modulated signal. One is mounted on the bottomside (Unit 721) and the other topside (Unit 720). The bottomside transducer is omnidirectional and is used at or near the surface to establish communications with the support ship. The topside transducer is directional and oriented vertically, toward the surface for deep submergence use.

4-104. Operation. Voice communication is achieved by use of a low-impedance hand-held microphone and panel-mounted speaker. A phone jack is provided on the panel so that earphones may be substituted for the speaker. A momentary push-button switch (U/W TEL-CW KEY) is mounted on the front panel for code transmission. An 800-Hz oscillator is used to replace the amplified voice signal for telegraphic code operation.

4-105. During a dive, underwater telephone transmission is required every 30 minutes. Upon descent and ascent from the bottom, the pilot usually transmits depth readings at 1000-foot intervals, using the underwater telephone.

4-106. SOUND-POWERED TELEPHONES. The hard-wire phone is a standard U.S. Navy sound-powered set which is used for communication between the sphere and sail of the vehicle. Prior to diving, the topside coordinator uses a handset plugged into a jack in the sail as a direct link to the sphere pilot, to check the underwater telephone and radio communication modes. Upon surfacing, the hard-wire phone is used by the boarding party to establish direct communications with the sphere crew.

4-107. VHF RADIO. The radio mode of communication can be used only on the surface. The FM radio, a Motorola HT 220 Handie-Talkie, Converta-Com, frequency modulates the voice signal on a crystal-controlled carrier frequency of 143.7 MHz. This communication mode is used when the vehicle is on the surface. It is also possible to use the radio as a modulated beacon. An 800-Hz oscillator is used to tone modulate the carrier frequency.

4-108. TAPE RECORDER. The tape recorder, a two-track monophonic Sony, Model No. TC-55, is used as a log to record dive information. It is connected to the communications panel (secured in special recess) for 5-VDC power provided by a DC-to-DC converter. The unit is not designed for direct recording through the communication system. During a dive, it is used separately with its hand-held microphone. The unit has a 2-hour total recording capacity, using standard cassette tape.

4-109. EMERGENCY/TRACKING PINGER (Unit 753). The vehicle communications system also includes the emergency/tracking pinger. This unit combines the functions of a tracking sonar and an emergency pinger. Ordinarily, tracking pings of 32 kHz at one-second intervals are emitted while the ship is submerged. 24-VDC power is supplied from the essential bus of the master power panel (Unit 700A33) for tracking operation and trickle-charging the self-contained emergency battery. In event of the loss of external 24-VDC power, the pinger shifts to the self-contained battery, initiating the emergency pinger function. In this mode, a different signal is emitted, with pings of 37 kHz, one per second for eight seconds, followed by 24 seconds of silence, and then repeated. An audible and visual alarm within the tracking receiver in the support ship is provided to sense the switch-over to emergency pinger.

4-110. VEHICLE TRANSPONDER (Unit 754). The final element of the communications system is the vehicle transponder, Bendix Model No. AT052 (modified). The unit automatically receives 24-VDC power through a fuse in the communications panel when the panel is energized. The transponder is mounted in the sail on the vehicle and is used to determine the distance to the ship. It receives its

interrogation pulse at a frequency of 7 kHz, and responds on a selected frequency between 12 kHz and 13.5 kHz in 500 Hz increments.

4-111. CAMERA SYSTEMS.

4-112. GENERAL. Two major camera systems are provided on the vehicle, the closed-circuit TV camera system and the 70mm still camera system. Both systems are used to permit viewing at operating depths with the use of the external lighting. The TV system incorporates a video tape recorder (VTR), for permanently recording observations for immediate playback and delayed viewing on the support ship. The 70mm cameras are used to provide a permanent "hard copy" record of observations. Camera mobility is provided by remote control of pan and tilt (P/T) mounting mechanisms located in the port, starboard and aft areas of the vehicle. A forward P/T mechanism, mounted above the manipulator arm, is used with lighting equipment to provide operator visibility. The lighting system is discussed in Chapter 3.

4-113. TV SYSTEM.

4-114. General. The closed-circuit TV system (Figure 4-26) includes the following external components: four TV cameras, a sync generator bottle, four pan and tilt mechanisms, four multiplex bottles, 24-VDC and 115-VAC power sources. All external operations are controlled through the multiplex system from the TV control and P/T control panels located in the sphere. Internal components include the TV control panel, lighting control panel, pan and tilt control and indicator panel, internal multiplex unit, single TV monitor, dual TV monitor, video tape recorder and 24-VDC power source.

4-115. The TV system provides the vehicle operators with the capabilities of viewing and recording observations of underwater objects, bottom areas of interest and working areas. The system also facilitates the observation/operation of bottomside-mounted equipment.

4-116. The three TV cameras (Units 724 - 726) of the system are interchangeable and may be mounted on either the aft, starboard, or port pan and tilt units. Provision is also made for operating a fourth TV camera (Unit 899) on the bow device from the forward multiplex bottle. Power for operation of the individual TV cameras comes from the particular multiplex bottle associated with the location and installation of the camera. Control of the TV camera focus, iris, and zoom is exercised from the TV control panel through the multiplex system to the camera.

4-117. TV Cameras (Units 724 - 726). The vehicle is equipped with three Hydro Products, TC-125-T2 television cameras. The TC-125-T2 unit is a black and white (B&W) underwater television camera, which is contained in a pressure-proof cylindrical housing. This housing is constructed of titanium and designed for use at depths to 20,000 feet. The housing contains an optical system (lens and focus control), a vidicon television camera tube, and associated electronic circuitry. An input has been provided for an external sync, however the unit is equipped with internal circuitry to generate sync signals in the event of low external sync signal level or loss of sync. An input has also been provided for controlling the focus of the camera lens.

CAUTION

The television TV camera vidicon tube will be damaged if the sensitive photoconductive target surface in the front of the tube is exposed to any high-intensity light source. When the unit is out of the water, a lens cover should be installed to avoid inadvertant exposure to the sun, reflections or any bright light.

4-118. TV Camera (Unit 899). The fourth TV camera provided on the vehicle is a Hydro Products, Model TC-150-Mil-ST-Z-T. This B&W camera incorporates a silicon target sensor, zoomar lens, and solid state circuitry, all contained in a titanium housing for operation at depths to 20,000 feet. The silicon target sensor tube used in this camera is more sensitive than the vidicon tubes used in Units 724 - 726, and thus provides a sharper and faster responding picture. While this TV tube is more sensitive than the vidicon tube, it is not susceptible to damage when exposed to sources of high-light levels, such as direct exposure to the sun.

4-119. The Unit 899 TV camera has inputs for remote control of the focus, iris, and motors operating the zoomar lens. An input has also been provided for an external sync signal, however the camera is equipped with internal circuitry to generate sync signals. The internal sync generator is used in the event of low signal level or loss of external sync signal.

4-120. Pan and Tilt Mechanisms (Units 727 - 729, 709). There are four pan and tilt (P/T) units (Hydro Products, Model RP-31) mounted on the vehicle. The aft P/T unit (729) is mounted on the horizontal stabilizer; the port and starboard P/T units (728 and 727) are located forward of the sphere on the underside of the vehicle. Unit 709 is located forward on the centerline, above the manipulator on the vehicle's bottom. All of the units are remote-controlled and provide two-axis control of movement, for the direction of television and photographic cameras as well as lighting. Movement in the horizontal direction or "panning", varies from 0 to 340 degrees about the vertical axis. Movement in the vertical axis or "tilting" varies from 0 to 190 degrees about the horizontal axis. Remote indication of the pan and tilt position is accomplished through the multiplex system by potentiometers in the P/T units. The P/T housings are oil-filled and pressure equalized for depths to 20,000 feet.

4-121. Operator control of the pan and tilt units is provided through the multiplex system from momentary contact switches on the pan and tilt control panel (Unit 700A66). These switches complete circuits from data bit inputs of the internal multiplex unit (700A211) to the multiplex channel common. When the inputs are sent through the multiplex system, outputs are activated in the external multiplex bottle to close a relay, which provides 115 VAC from inverter No. 6 (Unit 712) to the P/T unit for the particular control function desired i.e., right, left, up or down. Position indication data is then routed back through the multiplex system to the pan and tilt control panel indicator circuitry for readout. Since only two P/T units may be operated at the same time from the panel, the control position information is selected by relays in the aft and port external multiplex bottles.

4-122. External TV Sync Generator (Unit 898). The external TV sync generator bottle is located midship, bottom on the port side. This unit provides a common signal which is used to synchronize all TV camera scanning rates. The 24-VDC power to the sync bottle is provided by either the port, aft or starboard external multiplex bottles, with operator control being exercised from the SYNC GEN POWER switch on the TV control panel unit (700A101) in Bay 1. The external TV sync signal is fed to all four multiplex bottles, and then fed through to each of the TV cameras.

4-123. The external TV sync generator consists of a power board, four sync driver boards (one for each TV camera), and the sync generator board, all housed in a titanium pressure-proof bottle. The power board contains power supplies, as well as a redundant lockout relay system where power from any one of the port, aft and starboard multiplex bottles will energize the sync generator.

4-124. The four sync driver boards provide amplification of the generated sync signal which is fed into transformers for isolation of the sync channels. The output of the isolation transformers is then fed to the external multiplex bottles, and in turn to the TV cameras. The sync generator board consists of a crystal-controlled oscillator, an integrated circuit which generates a commercial broadcast, B&W TV sync signal. The commercial type sync signal is then processed through NAND and inverter digital integrated circuits and transistor circuitry to produce a closed-circuit TV type sync signal, which is amplified by the drivers for output to the cameras.

4-125. The Hydro Products TC-150 and TC-125-72 TV cameras are equipped to use the external sync signal. They are both provided with internal synchronizing electronics and will switch to the internal sync mode in the event of low external sync signal level or loss of sync signal. This autoswitching mode permits cameras to sync without input from the external sync generator, however the TV cameras may not all be scanning at the same rate.

4-126. TV CONTROL PANEL (Unit 700A101). The TV control panel (Figure 4-27) which is located in Bay 1 provides switching of the port, starboard, aft or forward video signal to any of the three TV monitors or through an amplifier circuit to the video tape recorder (VTR). The panel also provides control of the zoom, iris, and focus for the TV camera switched to the respective monitor or the VTR.

4-127. Panel Controls. The controls on the panel consist of momentary contact switches, which complete a circuit between a multiplex data bit input and the respective multiplex common. The closing of this circuit is sensed by the internal multiplex and transmitted to the external multiplex bottle and a relay is closed, providing plus or minus 12 VDC to the camera to energize the focus, zoom, or iris motors. Panel switches for the focus are labeled FAR or NEAR, for the zoom In or Out and for the iris OPEN or CLOSE. As a TV camera signal is switched from one monitor to another, the associated zoom, focus and iris controls are also switched to the switches controlling the particular monitor being observed.

4-128. Panel Power. Power is applied to the cameras through switches on the TV control panel. The applied power is sensed by the multiplex system, to actuate a relay in the external multiplex bottle connected to the camera in order to provide a constant current source to the camera. The SYNC GEN POWER switch on the control panel is provided for energizing the external TV sync generator through sensing of the power switch closure to three multiplex channels.

4-129. Plus 24-VDC power is fed through the TV control panel to the TV monitors. The +24-VDC power to the TV control panel is derived from the starboard power panel (Unit 700A27) and is used for energizing an input amplifier for the video tape recorder (VTR). The signal to the VTR goes through the input amplifier to boost the gain. A separate switch, VTR PREAMP ON-OFF, is provided for energizing the power supply, and in turn, the op-amp when using the video tape recorder.

4-130. PAN & TILT CONTROL PANEL (Unit 700A66).

4-131. GENERAL. The pan and tilt control panel (Figure 4-28) which is located in Bay 1, provides for indication and control of the pan and tilt (P/T) units. This is accomplished by switches and relays completing circuits from multiplex data bit inputs to multiplex common. When the data bit inputs are sensed by the multiplex system, relays are activated in the external multiplex bottles to provide 115 VAC from inverter No. 6 to operate the P/T units. Position indication for the P/T unit is provided to the pan and tilt control panel by cabling through the sphere penetrators from the external multiplex bottles.

4-132. SELECTION AND CONTROL. The pan and tilt control panel provides indication and control for a maximum of two P/T units at any one time, i.e., FWD or AFT, and PORT or STBD. Front panel switches are provided for selecting FWD or AFT and PORT or STBD. These selector switches provide the control information through the multiplex system to provide power for operation of the selected pan and tilt unit, as well as selecting the return of the proper pan and tilt indication.

4-133. PAN AND TILT POSITION INDICATION. Indication of pan and tilt positions is accomplished by zero-center meters with adjustable stops, connected to a sensing circuit which changes output with the changing of the input resistance of the potentiometer in the P/T unit. The adjustable stops on the meter are provided for de-energizing the pan and tilt unit to stop the operation at the selected limit by the activation of limit relays. A limit override switch is provided on the panel for bypassing the limit relay contacts to continue the operation beyond its limit.

4-134. Power. Power to the pan and tilt control panel is 24 VDC derived from the starboard power panel (Unit 700A27) to the power ON-OFF circuit breaker on the pan and tilt control panel.

4-135. TV MONITORS (Units 700A04, 700A09).

4-136. The vehicle is equipped with three television monitors, the single monitor (Unit 700A09) Figure 4-29, located in Bay 2 and the double (port and starboard) monitor (Unit 700A04) Figure 4-30 located in Bay 1. The TV monitors receive 24-VDC input power from the TV control panel (Unit 700A101). The TV monitors also receive input video from the TV control panel, which is selected from the PORT, STBD, FWD, and AFT TV cameras, or the VTR play-back.

4-137. The TV monitors are standard Conrac I, KNB9 monitors which display the picture from a composite video signal. Controls for the monitors include brightness, contrast, vertical hold, vertical size and horizontal hold.

4-138. VIDEO TAPE RECORDER (Unit 700A103).

4-139. The video tape recorder (VTR) located in Bay 1, is a Sony, Model AV-3400 VIDEORECORDER. The VTR receives 115 VAC, 60 Hz from the AC power panel. The video signal input and output of the VTR are controlled by the TV control panel. Video signals from any of the four TV cameras may be input to the VTR, and the VTR output may be displayed on any of the three monitors.

4-140. The VTR is a portable unit and may be removed from the sphere. The VTR is equipped for recording and playback of both video and audio signals. Video tape recording is accomplished by a rotary two-head helical scan, full field, composite video system.

4-141. 70mm SYSTEM.

4-142. GENERAL. The 70mm camera system (Figure 4-31) provides the capability to take still camera pictures at depths to 20,000 feet. There is provision for mounting three 70mm cameras on the vehicle, one on each of the aft, port and starboard pan and tilt (P/T) units. Facilities for electronic strobes are also provided on each of the P/T Units. In addition, circuitry is provided for stereo photograph operation using the port and starboard 70mm cameras simultaneously. Control of the cameras and strobes is exercised from the lighting control panel (Unit 700A15).

4-143. 70mm CAMERA (Units 733, 734, 715). The vehicle is equipped with two Hydro Products, PC-785 70mm still cameras. These cameras are designed for high-resolution pictures at depths up to 20,000 feet. The cameras offer standard preset, as well as remote setting of focus, shutter speed, aperture and remote actuation of the shutter. The cameras accept cartridges of color, or black and white film, up to 150 feet, which will accommodate 400 single-frame pictures. Power for the cameras is provided via the external 24-VDC distribution panel (Unit 804) through lighting contactor bottles and lighting junction boxes via potheads and then to the cameras.

4-144. Control signals for the camera iris, focus, and shutter speed are transmitted through the multiplex system from the lighting control panel inside the sphere. The camera actuate signal is originated from the lighting control

panel, fed through the penetrators to the aft, port or starboard multiplex bottle via a pothead to the selected cameras and strobes. The cameras advance the film automatically, after actuation, with a maximum cycle time of 8 seconds. Adjustments of the camera lens are accomplished through electronic circuitry which converts input voltages into movements of servo motors controlling adjustment of the lens. The camera lens, electronics and film pack are assembled in an aluminum pressure-proof housing.

4-145. ELECTRONIC STROBES (Units 735, 736, 750).

4-146. GENERAL. The vehicle is equipped with two Hydro Products, PF-735 electronic strobes, which provide a high-intensity light source for still photographs. The strobe is incased in an aluminum pressure proof bottle and consists of an acrylic lens, zenon flash tube, and electronic circuitry to charge a capacitor which provides the high-voltage for the flash tube. An input is provided on the strobe for selecting an output light intensity between 100 and 500 watt-seconds.

4-147. POWER AND CONTROL. Power to the strobe is provided via the 24-VDC distribution panel (Unit 804) through a lighting contactor bottle and lighting junction box to a pothead and then to the strobe. Control of the light intensity output is exercised from the controls for the 70mm camera on the lighting control panel (Unit 700A15). Control of the actuation of the strobe is provided from the 70mm actuate switches on the lighting control panel. The 70mm camera and strobes actuate simultaneously. The strobes require 6 to 9 seconds charging (cycling time) before they may be reactivated.

4-148. Since the 24-VDC power to the strobes is derived directly from the lighting contactor bottles, the forward multiplex bottle (Unit 902) must be energized to control lighting contactor bottle No. 2 (Unit 714) to provide power to the aft and starboard 70mm cameras and strobes. The port multiplex bottle (Unit 901) controls lighting contactor bottle No. 1 (Unit 713) which provides power to the port 70mm camera and strobe.

4-149. LIGHTING CONTROL PANEL (Unit 700A15).

4-150. GENERAL. The lighting control panel (Figure 4-32) contains the controls for the 70mm cameras and electronic strobes. The lighting control panel also contains the controls for the multiplex power and the external lights. The operation of the panel for the multiplex power and external lights is described in their respective sections.

4-151. CONTROL FUNCTIONS. The lighting control panel contains controls for three 70mm still cameras and associated strobe lights. Control of the camera settings and strobe power may be accomplished in two ways. A "coarse" selection of iris, distance and strobe power is effected by placing the range switch in the NEAR, MED or FAR position, and the ASA switch in the 80, 160 or 400 position depending on the speed of the film. A particular iris, distance and strobe power setting combination is selected by placing the RANGE switch in the FINE C position. This method permits a more varied setting of the camera

than the coarse selection. Table 4-2 shows the relationship between particular setting (fine control) of the iris, distance and strobe power switches, and the coarse settings of the range and ASA switches.

4-152. CONTROL CIRCUITRY. The camera-lighting control switches complete circuits between data bit inputs of the internal multiplex (Unit 700A211) and multiplex common for transmission of the particular setting to the external multiplex bottles. The data is decoded in the multiplex bottle into signal voltages consistent with the particular iris or focus setting for the 70mm camera or for controlling strobe power. To minimize the number of data bits used to code the particular position of a switch, two bits are used for the four "strobe power" positions, three bits for the six "iris" position and three bits for the eight "distance" positions. The RANGE and ASA switches define particular iris, distance and strobe power settings as shown in Table 4-2 and require no additional bit coding. The coding of a particular switch setting into a particular set of two or three bits is accomplished by the wiring of the switches on the lighting control panel, and the decoding is performed by relays, outboard in the external multiplex bottles to produce a particular signal for input to the 70mm camera or strobe.

4-153. CONTROLS AND INDICATORS. Switch indicators are provided for camera actuation and for indicating the operation of the camera. When power is applied to the panel and a camera, the switch indicator will illuminate green. Depressing and releasing the switch applies a momentary ground to the camera actuate line and activates the camera and strobe. On the panel, the counter for the camera is advanced and the color of the switch indicator changes from green to amber, indicating the film is advancing. Upon completion of the film advance, the circuitry behind the panel switches the light back to green and another picture may be taken.

4-154. A PORT/STBD STILL CAMERA SINGLE STEREO switch is provided on the panel to accommodate single or stereo operation of the port and starboard 70mm cameras. If stereo operation is selected, the PORT and STBD switch indicators will illuminate blue rather than green, and depressing one of the actuate switches will actuate both cameras and strobes and advance both counters.

4-155. POWER. The 24-VDC power for the lighting control panel is provided from the external lights circuit breaker on the starboard power panel (Unit 700A27). Power ON-OFF switches are provided on the lighting control panel for control of power to the 70mm camera and strobe by the lighting contactor bottles via the multiplex system. The ON-OFF switches also actuate frame counting circuitry within the panel.

Table 4-2. 70mm Camera Control Functions

CONTROL	FINE SWITCH * POSITION	COARSE SWITCH POSITION
IRIS f/2.8	IRIS - 2.8	None
f/4	IRIS - 4	None
f/5.6	IRIS - 5.6	None
f/8	IRIS - 8	ASA - 80, RANGE - FAR
f/11	IRIS - 11	ASA - 160, RANGE - FAR
f/16	IRIS - 16	ASA - 400, RANGE - FAR ASA - 80, 160, 400 RANGE-MED ASA - 80, 160, 400 RANGE-NEAR
DISTANCE 1.5 Feet	DISTANCE - 1.5	None
2 Feet	DISTANCE - 2	None
3 Feet	DISTANCE - 3	None
5 Feet	DISTANCE - 5	ASA - 80, 160, 400 RANGE-NEAR
8 Feet	DISTANCE - 8	None
12 Feet	DISTANCE - 12	ASA - 80, 160, 400 RANGE-MED
25 Feet	DISTANCE - 25	ASA - 80, 160, 400 RANGE-FAR
60 Feet	DISTANCE - 60	None
STROBE POWER 100 Watt Sec 100 Watt Sec	STROBE PWR - 100	ASA - 80, 160, 400 RANGE-NEAR ASA - 400, RANGE - MED
200 Watt Sec	STROBE PWR - 200	ASA - 160, RANGE - MED
400 Watt Sec	STROBE PWR - 400	ASA - 400, RANGE - FAR
500 Watt Sec	STROBE PWR - 500	ASA - 80, RANGE - MED ASA - 80, 160, RANGE - FAR

* RANGE Switch in FINE C position.

4-156. MULTIPLEX SYSTEM.

4-157. GENERAL. The multiplex system for the vehicle, consists of an internal multiplex unit (700A211), Figure 4-33, which sends data to four external multiplex units (900-903) Figure 4-34. The data sent contains control information for the lighting, 70mm still camera, strobe, TV camera and pan and tilt systems. The multiplex system is an integral part of these sensor systems.

4-158. CIRCUIT COMPONENTS. The heart of the multiplex system are Larse Corporation, Data Communicator Sen, Sen Expander, Rede, and Rede Expander Modules. The Sen and Sen Expander modules are located in the internal multiplex unit and encode the data for transmission. The Rede and Rede Expander Modules in the external multiplex unit accept the data, decode it and provide a signal for the function desired.

4-159. CIRCUIT DESCRIPTION. The basic theory of the multiplex system is that a switch or relay contact closure completes a circuit between a data bit input of a SEN or SEN Expander Module and the multiplex common (power supply return) which turns a transistor inside the module to an "ON" state. The SEN module provides for 16 data bit inputs and the SEN Expander also provides for 16 Data bit inputs, thus comprising the sensing of 32 contact closures. The 32 transistors of the 32 data bit inputs are sensed sequentially and encoded with clock and sync pulses, to form a 67-bit serial code as shown in Figure 4-36. In this serial code, a high data bit indicates a transistor is in an "ON" state due to a contact closure, and a low data bit denotes a transistor in an "OFF" state due to an open set of contacts.

4-160. The Sen Module transmits this 67-bit serial code through the penetrators, to an external multiplex Rede Module. The Rede Module decodes the first 16 bits with associated clock and sync bits from the serial code and transfers the remaining 16 data bits with associated clock and sync bits to the Rede Expander Module for decoding. The decoding takes place in two ways; first the serial code is checked for proper location of the clock and sync bits, and second, a set of the 32 previous data bits is stored and the newest set compared with the stored set to verify that each data bit is in the same position (high, or low). The output transistors in the Rede and Rede Expander Modules are then turned ON or OFF depending on the high or low position of the data bit. Once an output transistor is turned ON, it will stay ON until the data bit position is changed to low or the Rede or Rede Expander Module is powered down. The output transistors control the current flow to operate relays inside the external multiplex unit to provide the desired output control signal.

NOTE

If transmission between the internal and an external multiplex unit is broken while the external unit is still energized, all control signals of the external multiplex energized at the time of transmission failure, will remain energized until the data transmission is restored and the controlling contact closure opened, or the external multiplex unit is de-energized.

4-161. INTERNAL MULTIPLEX (Unit 700A211). The internal multiplex unit (Figure 4-33) is located behind Bay 1 inside the sphere. This unit provides the coding of 128 data bits, using 4 channels of 32 bits each. Each channel uses one Sen, one Sen Expander and 15-VDC power supply. The Sen, Sen Expander and power supply in each channel are identical and interchangeable.

4-162. Power. The 24-VDC power for the power supplies which energize the Sen and Sen Expander, comes from the Exterior Lights circuit breaker on the starboard Power Panel (Unit 700A27), via the respective multiplex channel circuit breaker on the lower left corner of the lighting control panel (Unit 700A15) (Figure 4-34). This 24 VDC is also sent outboard as power control for powering up the respective external multiplex unit.

4-163. Table 4-2 provides a breakdown of the functions associated with respective data bits. Contact closures for the control of the zoom, iris, focus, and turning on the constant current supply for the TV camera and power control for the external TV sync generator are from the TV control panel (Unit 700A101). Contact closures for the control of lights, the 70mm still camera, iris and focus and the strobe power are from the lighting control panel (Unit 700A15). The contact closures for pan and tilt (P/T) selection and control of panning and tilting are provided from the pan and tilt control panel (Unit 700A66).

4-164. EXTERNAL MULTIPLEX (Units 900-903). There are four external multiplex units (Figure 4-34) one each for the port, starboard, aft, and forward multiplex channels. The aft external multiplex unit (903) is located on the port skeg above the horizontal stabilizer on the aft end of the vehicle. The port (Unit 901), starboard (Unit 900) and forward (Unit 902) external multiplex units are located on the underside, forward portion of the vehicle. Each of the units is identical, and they are interchangeable.

4-165. The external multiplex units receive the data sent from the Sen Modules in the internal multiplex unit and decode the data to provide signals for controlling lights, TV cameras, pan and tilt units, 70mm still cameras and strobes and the external TV sync generator. Refer to the respective system diagram for the equipment controlled by a particular external multiplex unit.

4-166. Figure 4-34 shows the breakdown of a typical external multiplex unit, in this case, the port external multiplex bottle (Unit 901). Power to energize multiplex bottle comes from the 24-VDC distribution panel (Unit 804) and is controlled by relay K3 in the multiplex unit. Relay K3 is controlled by 24-VDC as a power control signal coming from the lighting control panel, fed through the internal multiplex unit and then outboard to the external multiplex unit. When K3 closes, the 15-VDC power supply is energized providing 15 volts for the Rede Module, Rede Expander Module, and relays. Closing K3 also provides 24-VDC for control signals to be switched to the outputs by relays.

Table 4-3. Multiplex Data Bit Functions

DATA BIT	FWD MULTIPLEX	PORT MULTIPLEX	STBD MULTIPLEX	AFT MULTIPLEX
0	CONSTANT CURRENT FOR TV CAMERA →			
1	PAN RIGHT →			
2	PAN LEFT →			
3	TILT UP →			
4	TILT DOWN →			
5		PAN & TILT DATA		PAN & TILT DATA
6	ZOOM OUT →			
7	ZOOM IN →			
8	FOCUS FAR →			
9	FOCUS NEAR →			
10	IRIS CLOSE →			
11	IRIS OPEN →			
12 # 9				
13 # 8				
14 #10				
15 # 7				
16		SYNC GEN POWER →		
17 # 3	AFT STBD SILO LIGHT	AFT PORT FLOOD #4	STBD TV #1	STBD TV #2
18		STILL CAMERA FOCUS 1 →		
19		STILL CAMERA FOCUS 2 →		
20		STILL CAMERA FOCUS 3 →		
21 # 1	FWD FLOOD #2	FWD STBD FLOOD #1	PORT TV #1	AFT TV #2
22 # 2	STBD STROBE AFT STROBE	PORT STROBE	AFT TV #1	PORT TV #2
23 #11				
24		STILL CAMERA IRIS 1 →		
25		STILL CAMERA IRIS 2 →		
26		STILL CAMERA IRIS 3 →		

Table 4-3. Multiplex Data Bit Functions (Continued)

DATA BIT	FWD MULTIPLEX	PORT MULTIPLEX	STBD MULTIPLEX	AFT MULTIPLEX
27		STROBE PWR 1		
28		STROBE PWR 2		
29 # 4	AFT STBD FLOOD #3	AFT PORT SILO LIGHT	SEARCH #3	SEARCH #4
30 # 5	FWD PORT SILO LIGHT	FWD STBD SILO LIGHT		
31 # 6	SEARCH #1 & 2			

4-167. The Rede and Rede Expander Modules energize relays on relay boards No. 1 and No. 2, and transistors on the resistor board which energize relays K1, K2, and K4-6, depending on the position of the respective data bits. Table 4-3 indicates the function controlled by the relay associated with a particular data bit.

4-168. Analog signals such as 70mm camera, strobe actuate, and TV video signal are fed through the external multiplex unit, and directly on to their respective inboard panels as shown in Figure 4-34 and Figure 4-27. Since only two Pan and Tilt units may be energized at one time, port or starboard, forward or aft, then the selection of the proper pan and tilt position information is accomplished in the aft and port external multiplex units. In the case of the port and starboard pan and tilt units, the selection is done by one of the resistor board relays as indicated in the external multiplex, Figure 4-36.

4-169. Control of the pan and tilt units is accomplished by the input of 115 VAC from inverter No. 6 (Unit 712) to the external multiplex unit, which is switched using relays to pan left or right, tilt up or down, outputs for the Pan and Tilt mechanisms.

4-170. Control to the external TV sync generator is accomplished by using relays to switch 24 VDC to the output to the generator, which energizes it, and an external TV sync signal is then sent to all multiplex units where it is fed through to the TV cameras.

4-171. Control of the TV cameras is accomplished by switching 24 VDC to the 12 VDC, and constant current supplies, energizing them, and energizing the appropriate relay providing the 12-VDC signal for the zoom IN or OUT, focus Near or Far, or iris Open or Close outputs. A potentiometer is provided inside the External multiplex bottles for adjusting the current output for the requirements of different TV cameras. The potentiometer is accessible through the evacuation plug of the unit.

4-172. Control outputs 1 through 11 are provided with 24 VDC as control signals for energizing contactors to provide power to the external lights. In the case of the port external multiplex unit, the control signals go to lighting contactor bottle No. 2 for energizing contactors to provide power to two silo lights and two floodlights, and providing port 70mm camera and strobe power.

4-173. Iris and focus control for the 70mm still camera is accomplished by inputting 24 VDC from the camera to a voltage divider network in the external multiplex unit, and energizing relays to select the voltage consistent with the particular iris or focus setting for output. A similar situation is used for controlling the strobe power, by using relays to select a resistance value for output to the strobe.

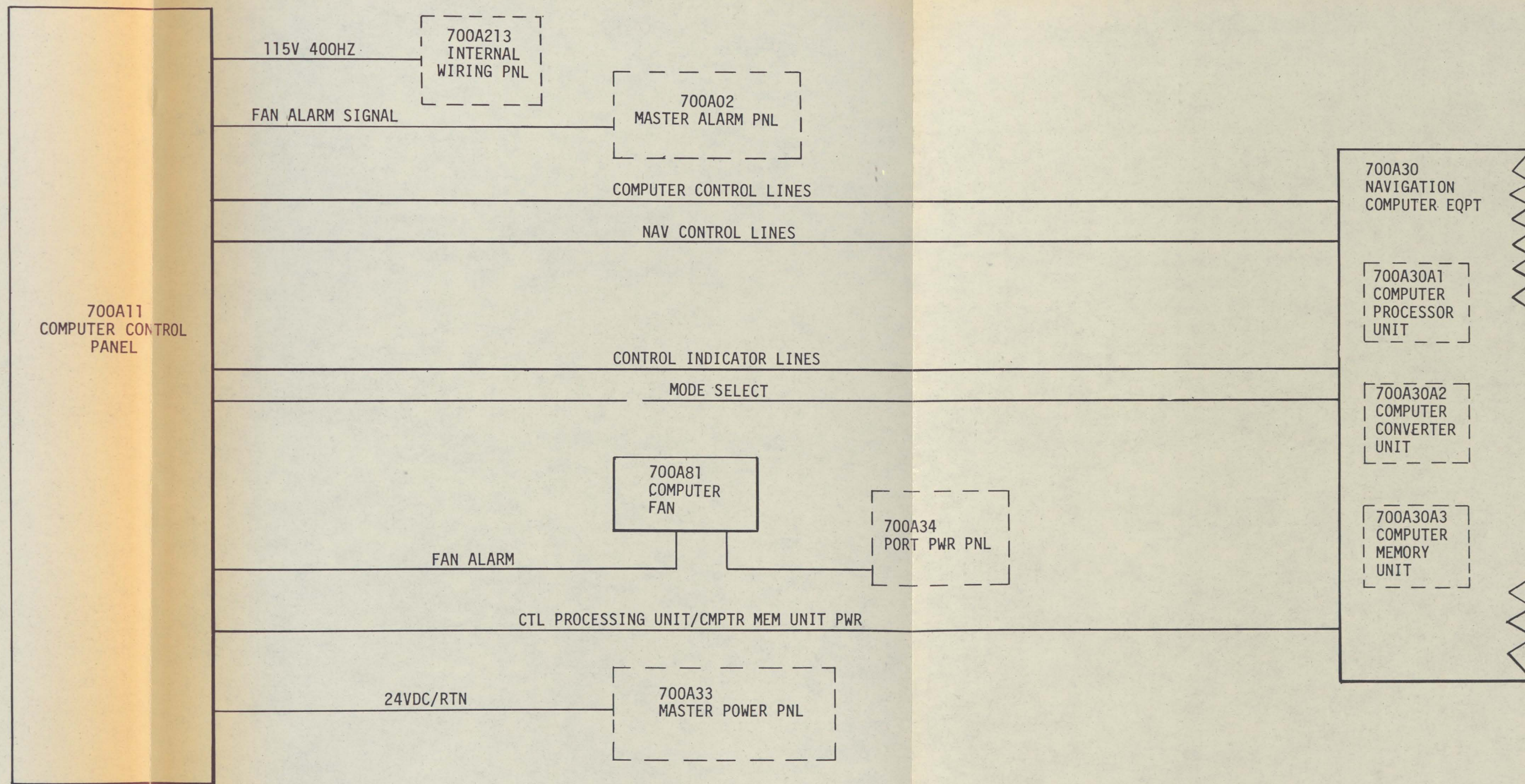

FIGURE 4-1. NAVIGATION COMPUTER SYSTEM SHEET 1 OF 2

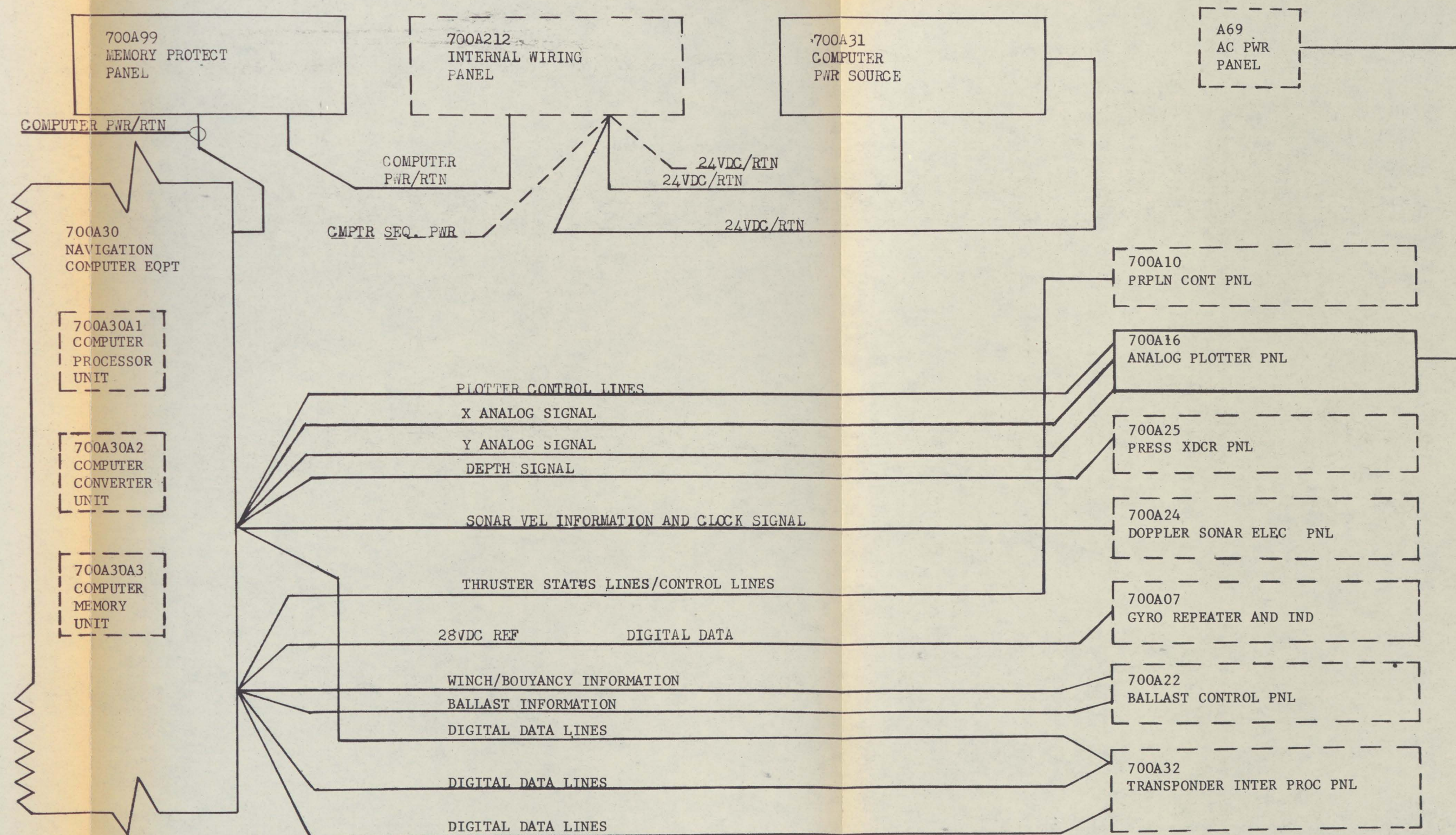

FIGURE 4-1. NAVIGATION COMPUTER SYSTEM SHEET 2 OF 2

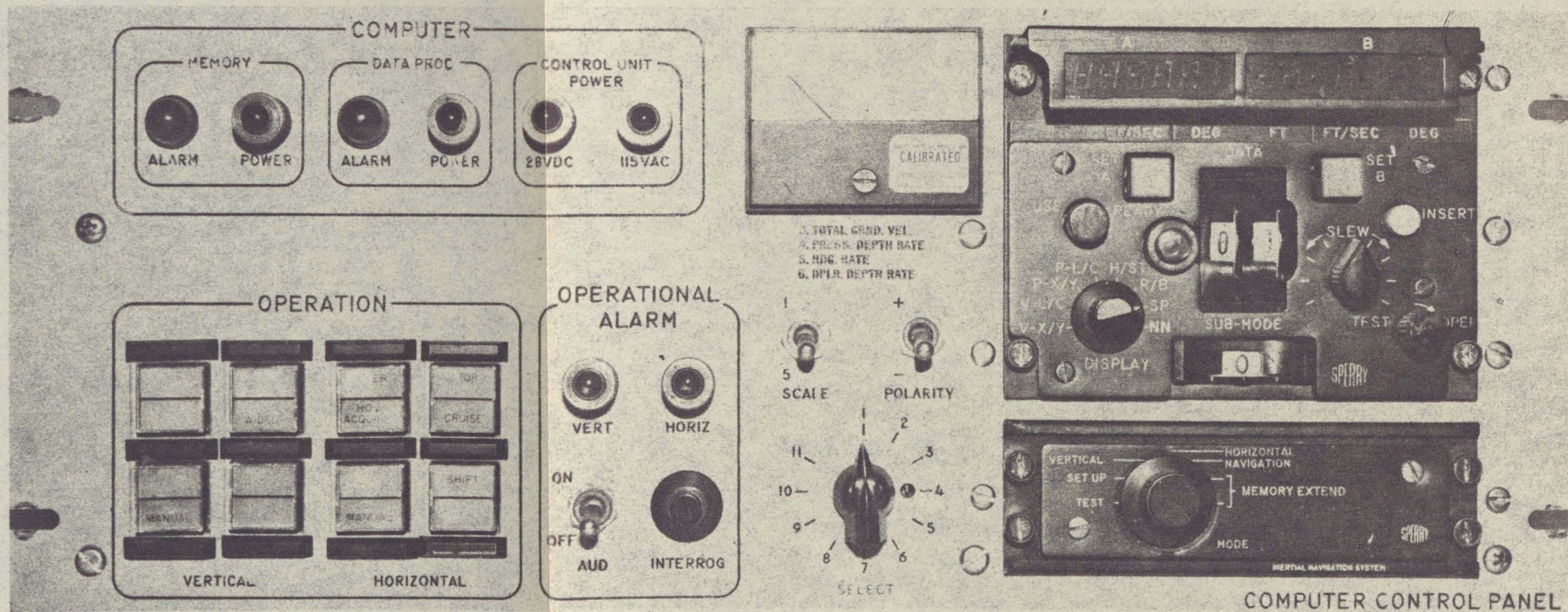

FIGURE 4-2. COMPUTER CONTROL PANEL(UNIT 700A11)

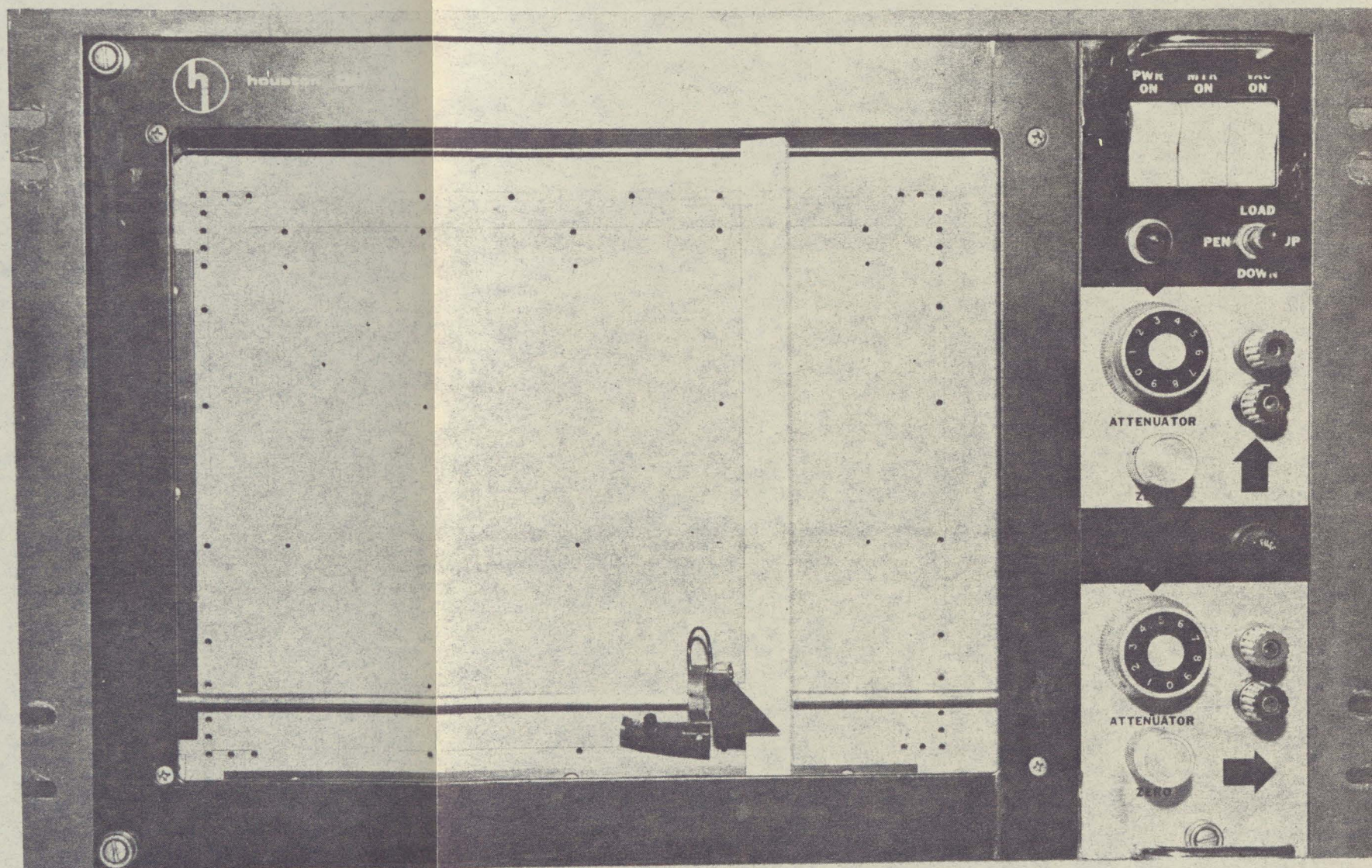

FIGURE 4-3. ANALOG PLOTTER (UNIT 700A16)

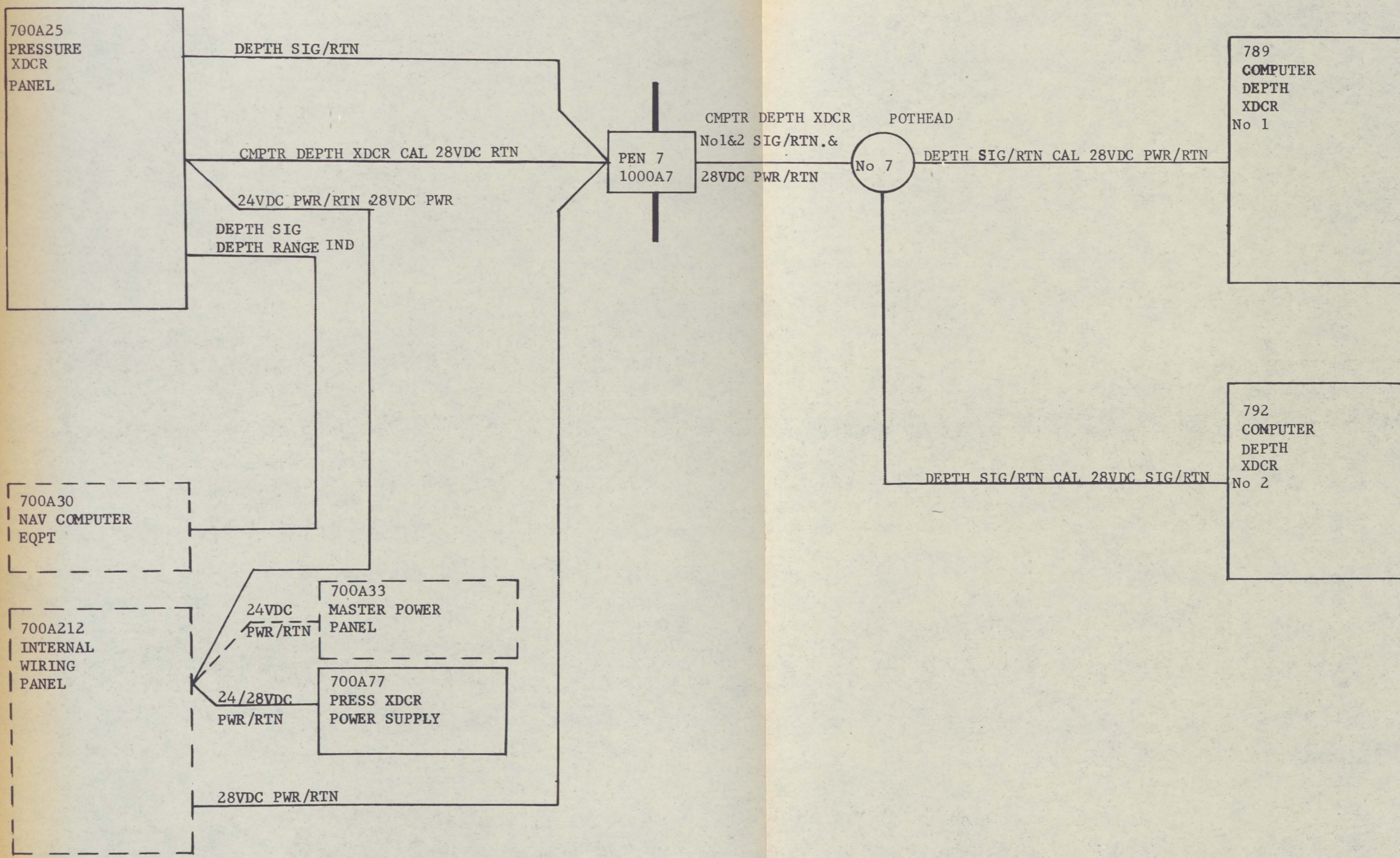

FIGURE 4-4. COMPUTER DEPTH TRANSDUCER SYSTEM

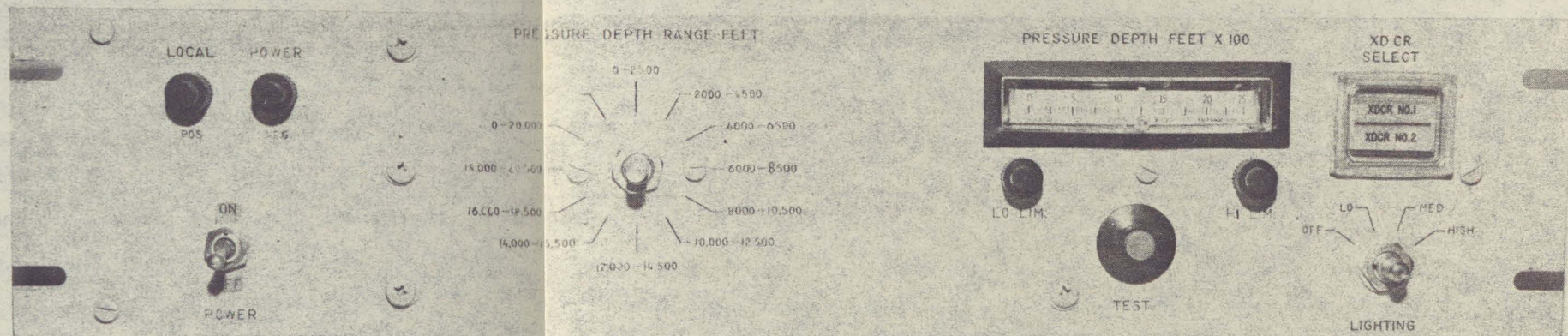

FIGURE 4-5. PRESSURE TRANSDUCER PANEL - UNIT 700A25

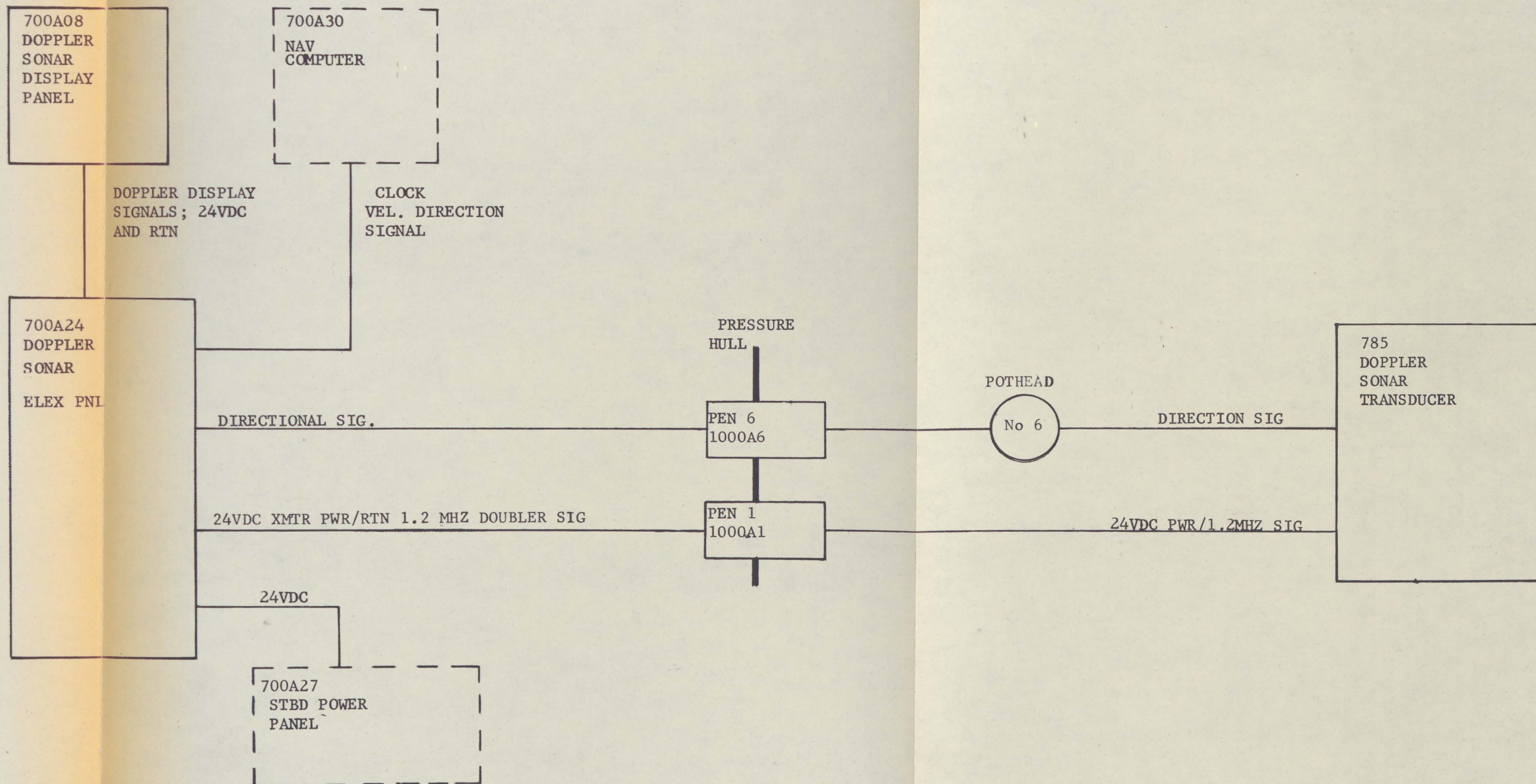

FIGURE 4-6. DOPPLER SONAR SYSTEM

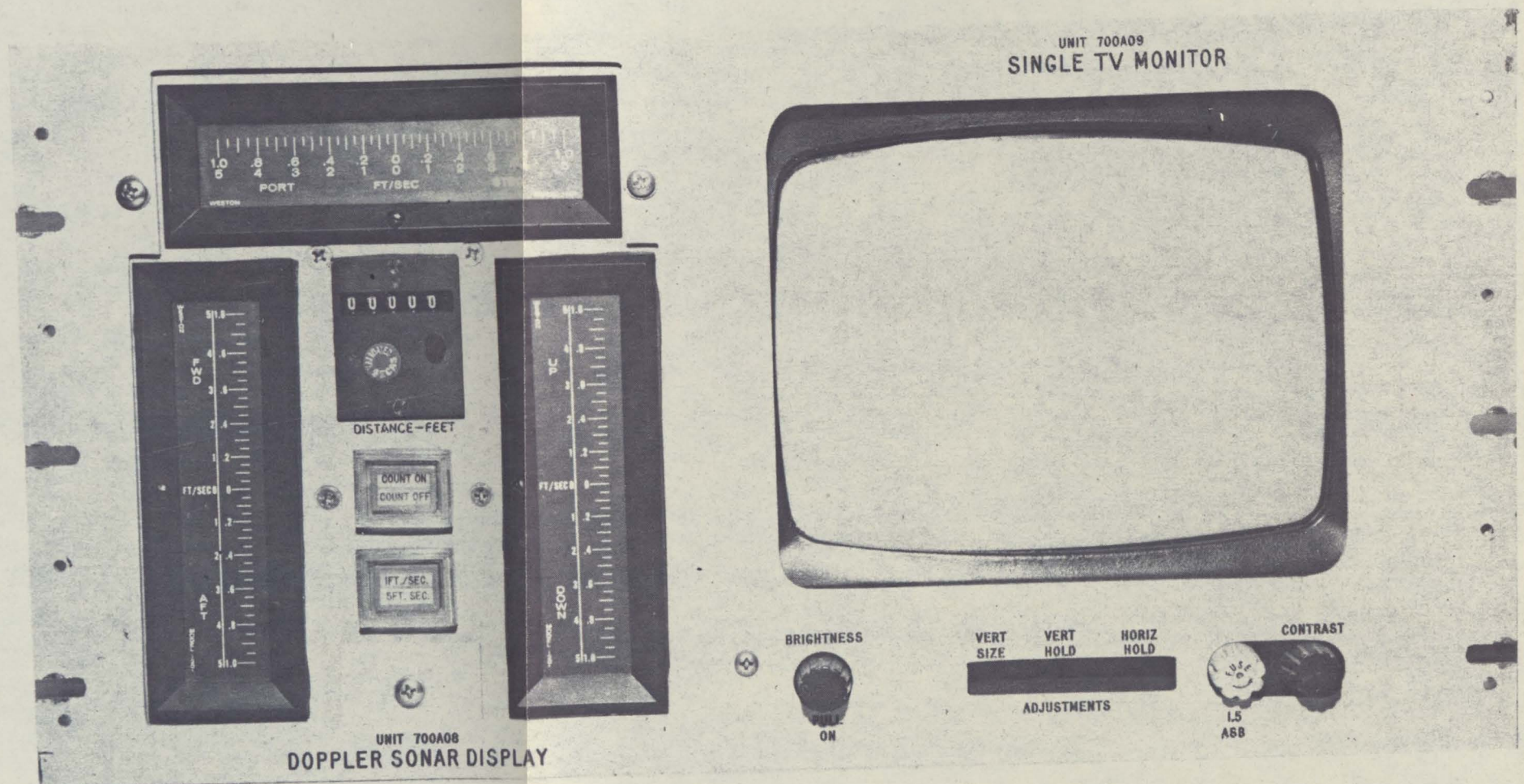

FIGURE 4-7. DOPPLER SONAR DISPLAY

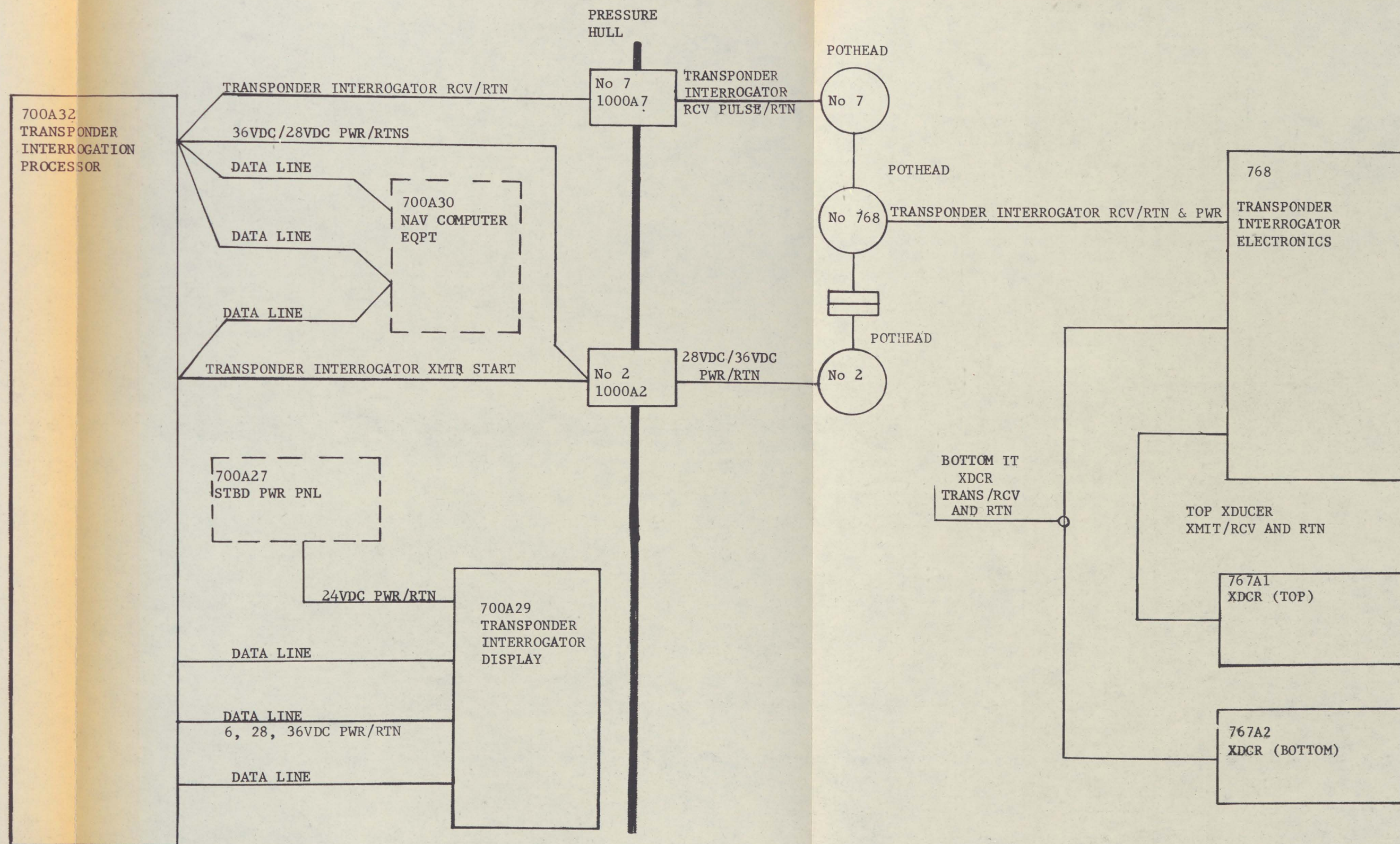

FIGURE 4-8. NAVIGATIONAL TRANSPONDER INTERROGATOR SONAR (TIS) SYSTEM

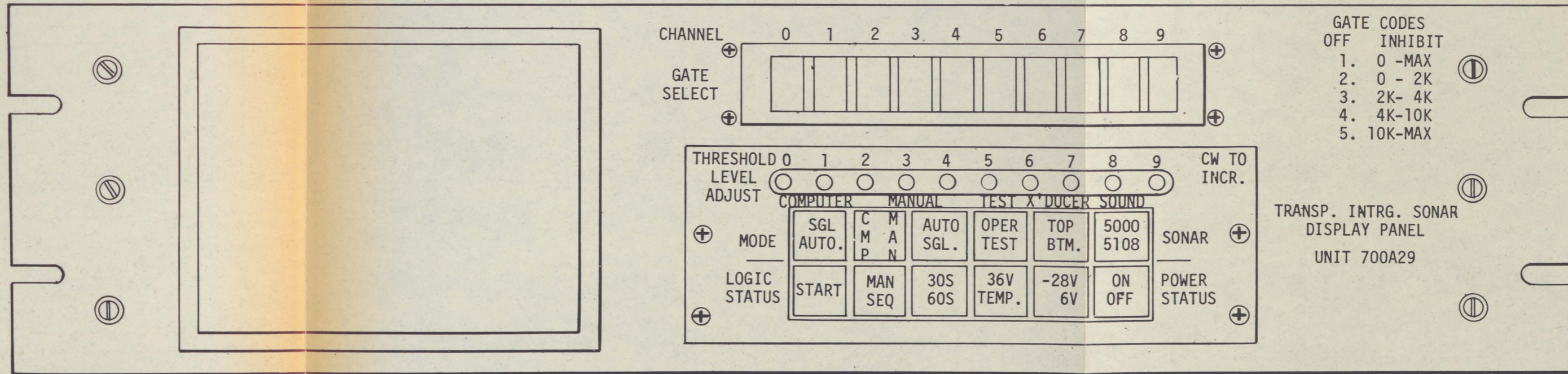

FIGURE 4-9. TRANSPONDER INTERROGATOR PROCESSOR AND DISPLAY UNITS

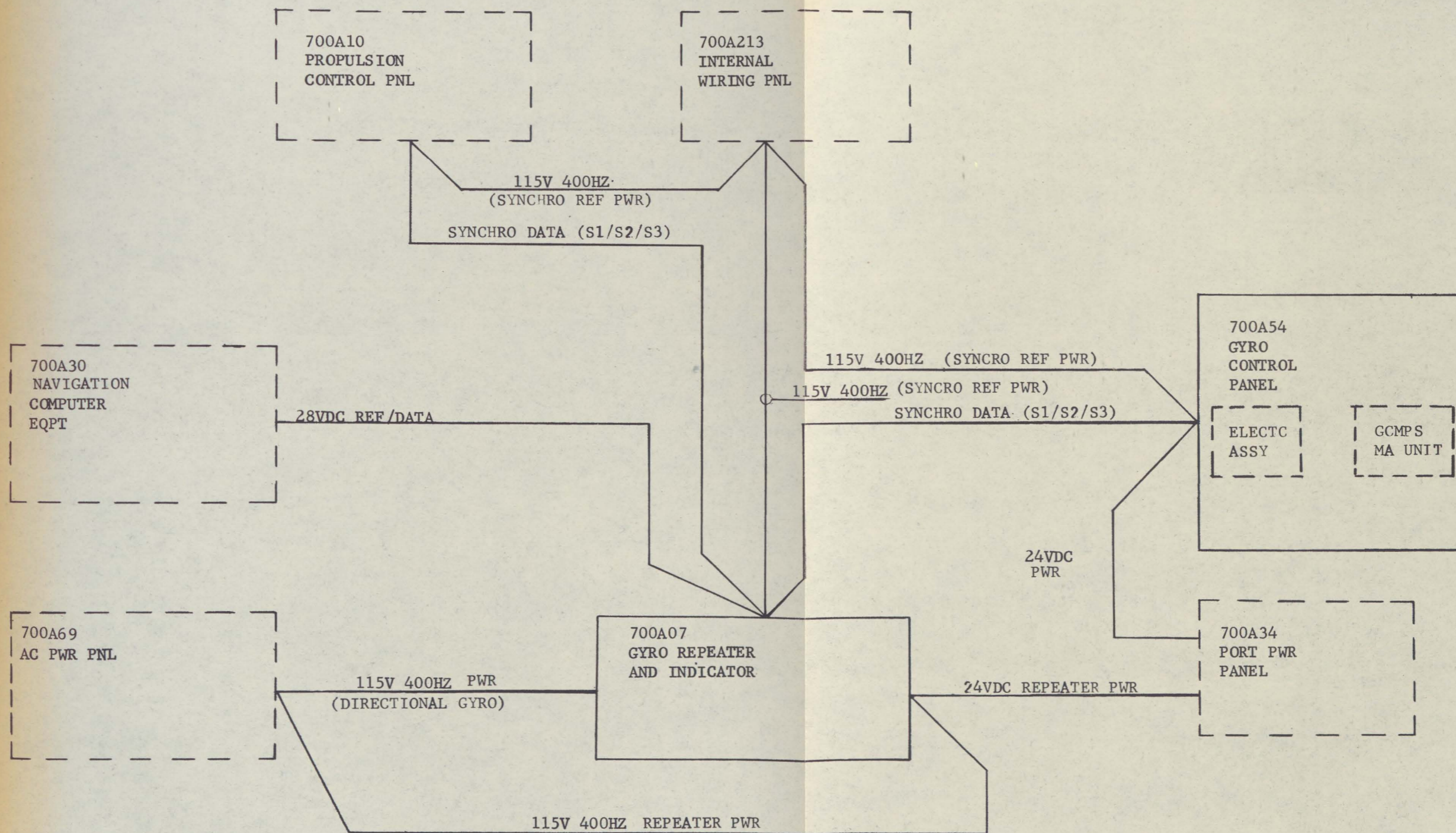

FIGURE 4 - 10. GYROSCOPE AND HEADING DISPLAY SYSTEM

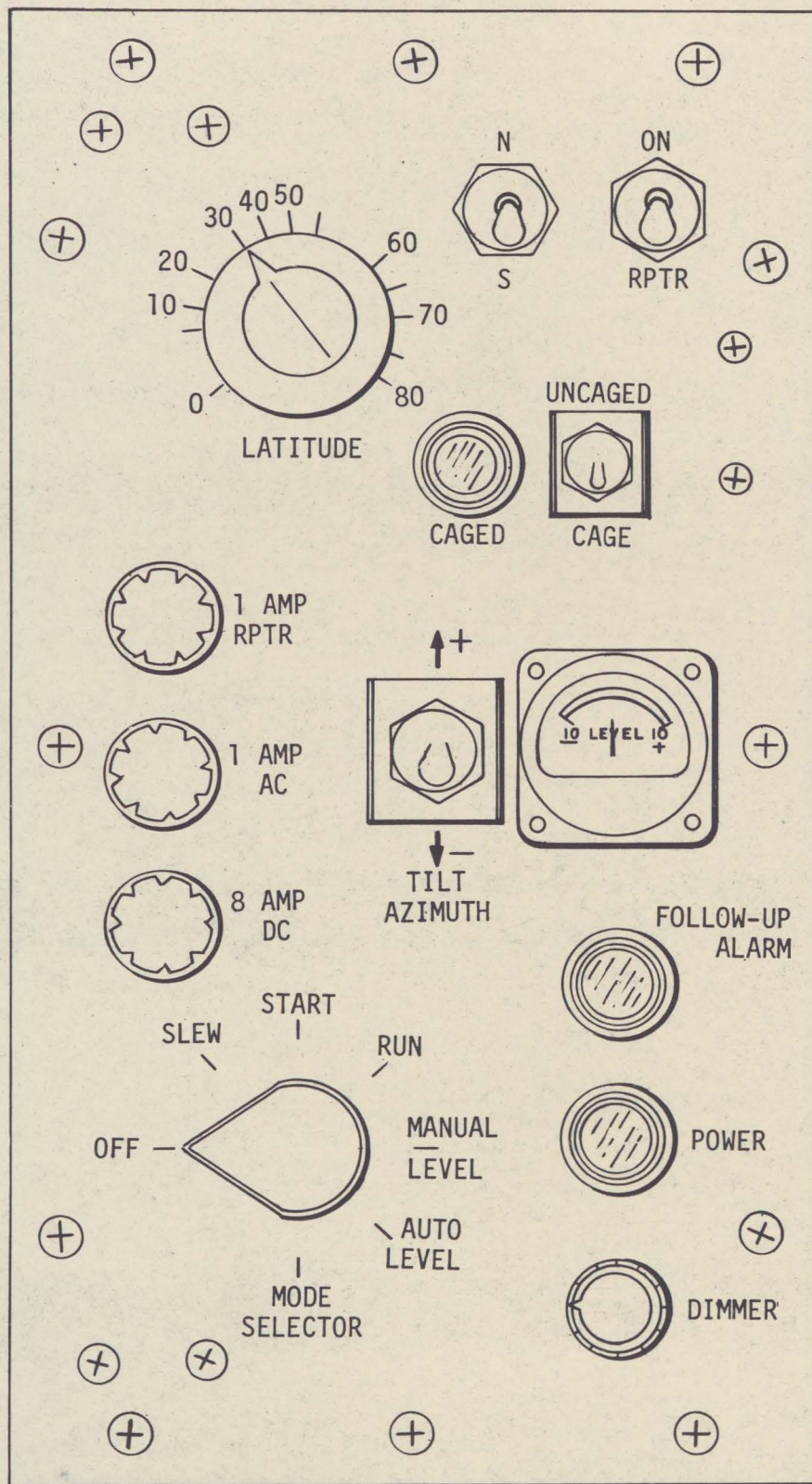

FIGURE 4-II. GYROCOMPASS CONTROL PANEL

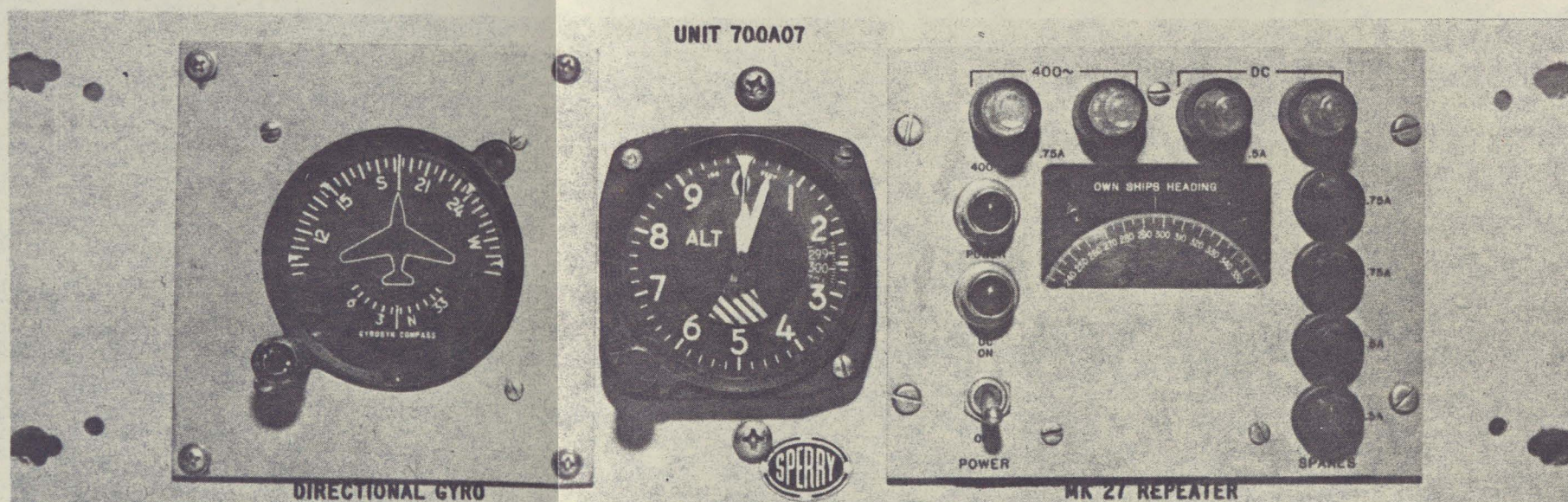

FIGURE 4-12. GYROCOMPASS REPEATER AND INDICATOR

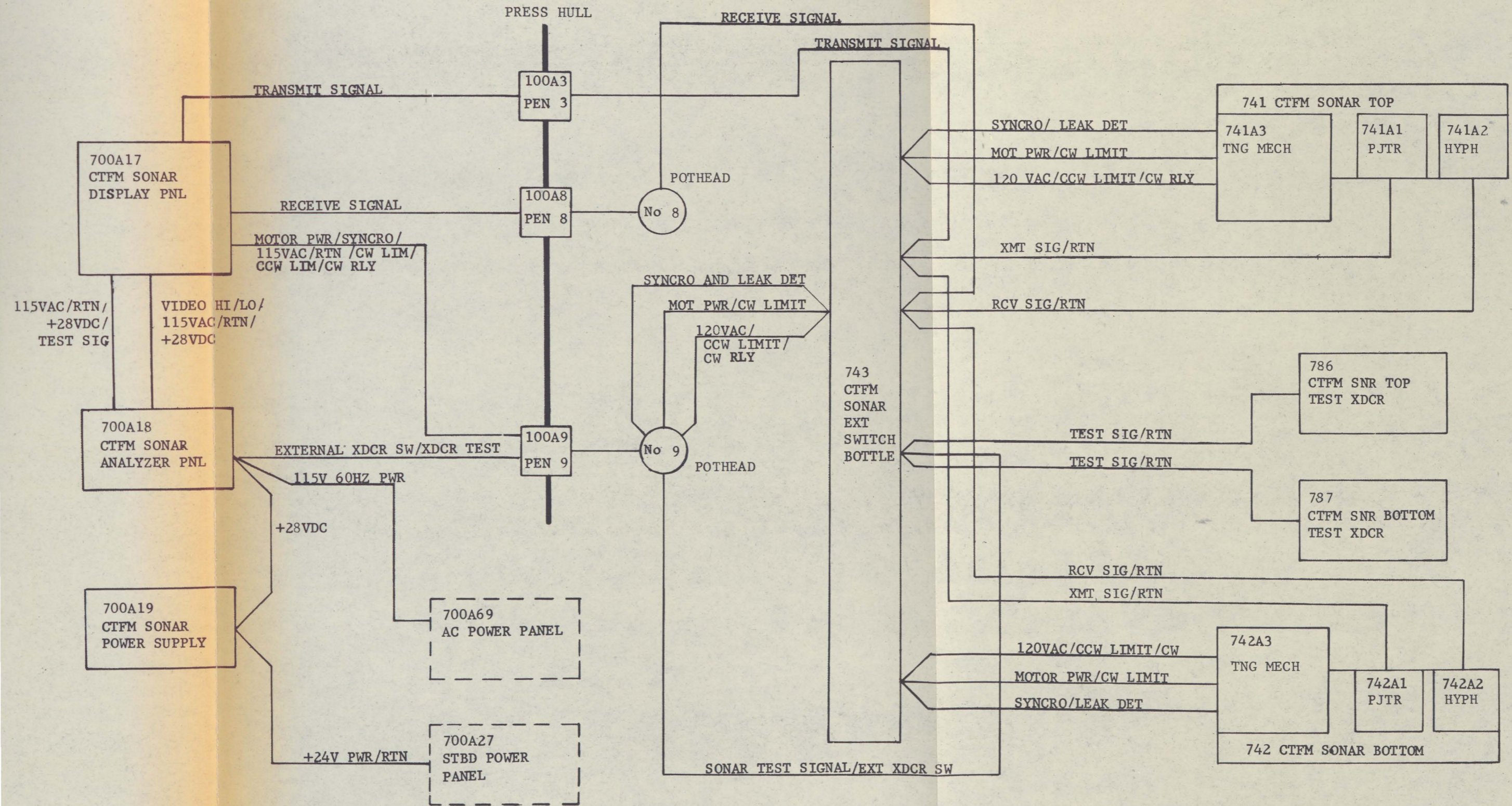

FIGURE 4-13. CTFM SONAR SYSTEM

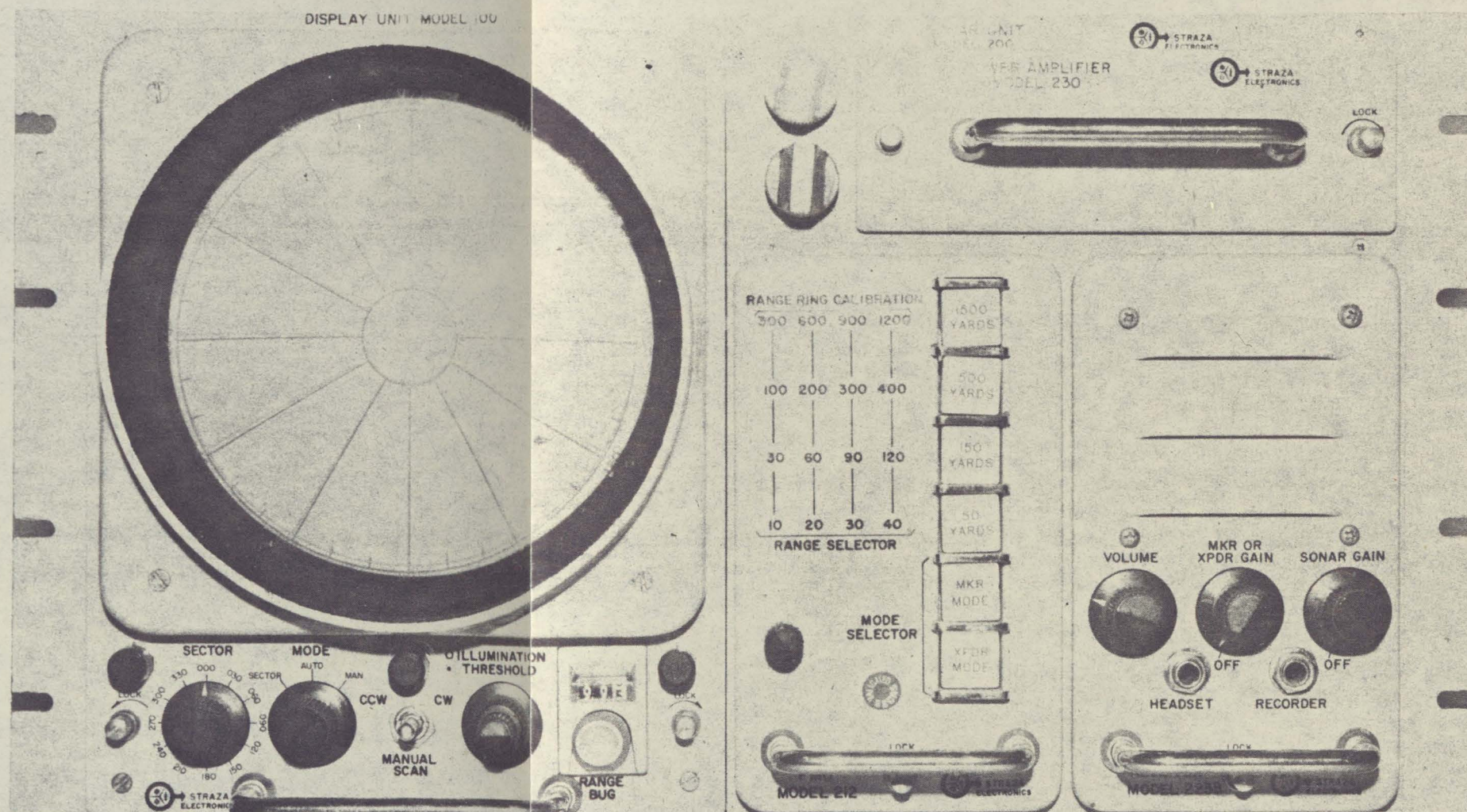

FIGURE 4-14. CTFM SONAR DISPLAY (UNIT - 700A17)

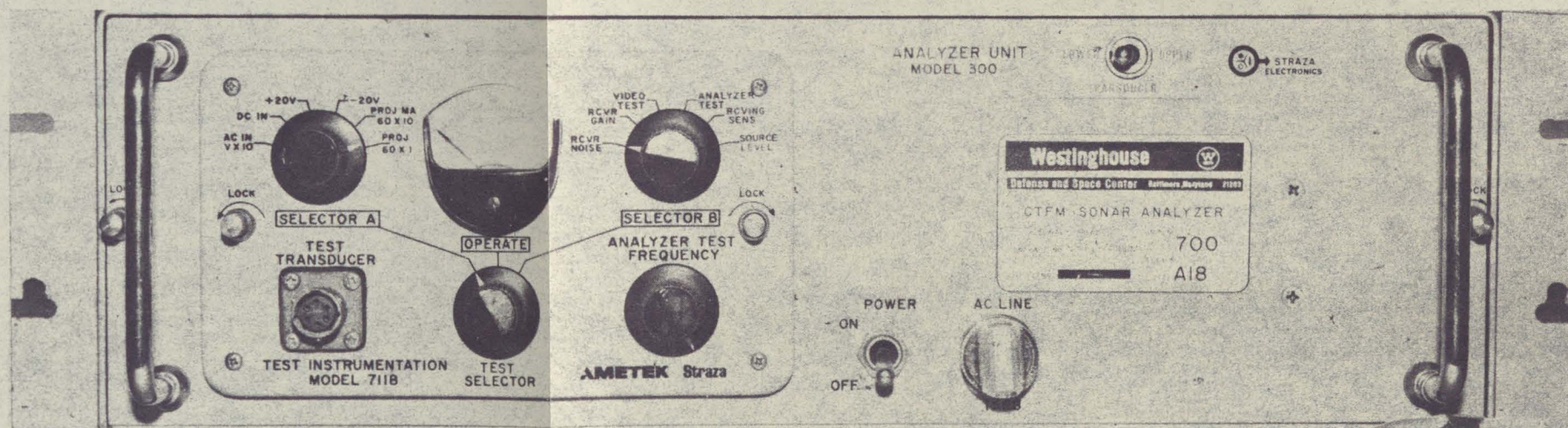

FIGURE 4-15. CTFM ANALYZER (UNIT-700A18)

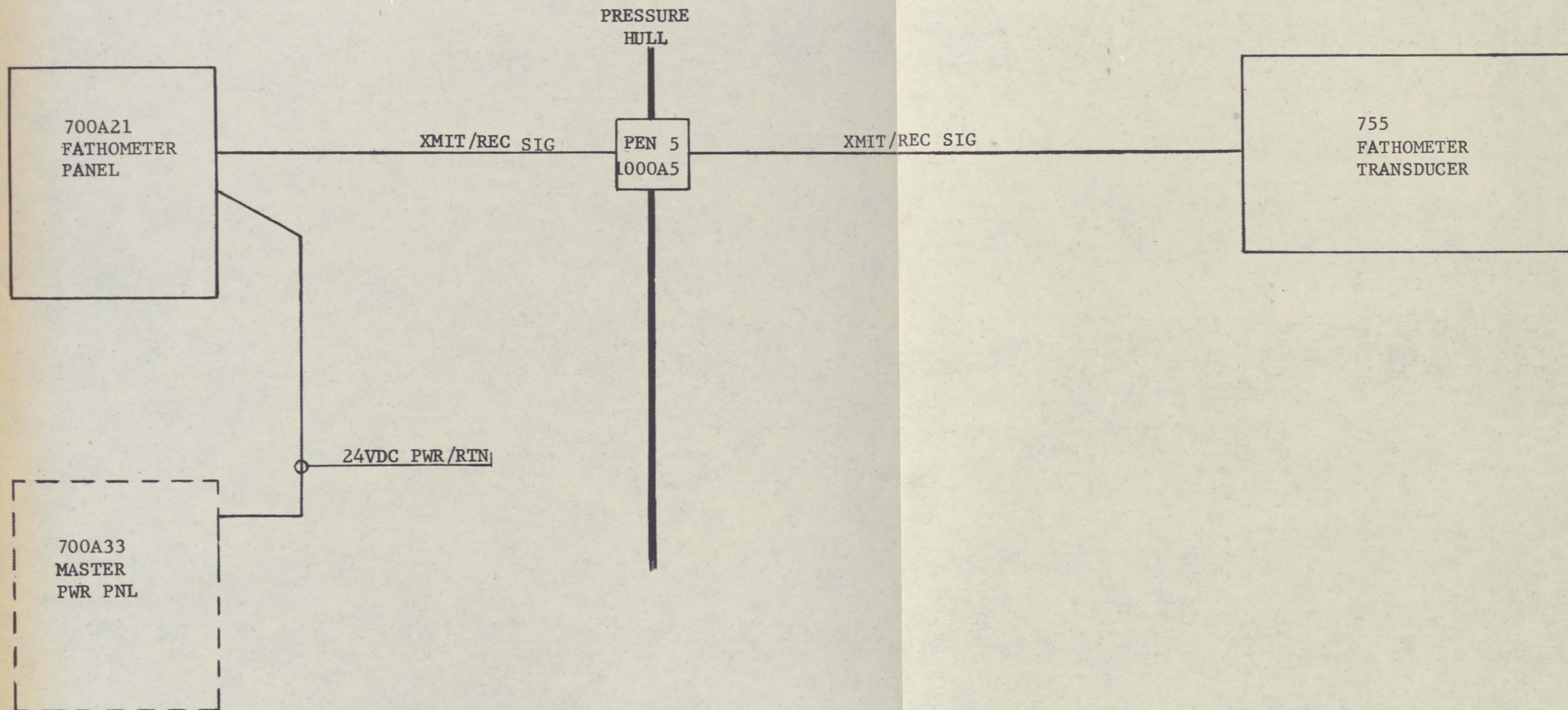

FIGURE 4-16. FATHOMETER (DEPTH SOUNDER) SYSTEM

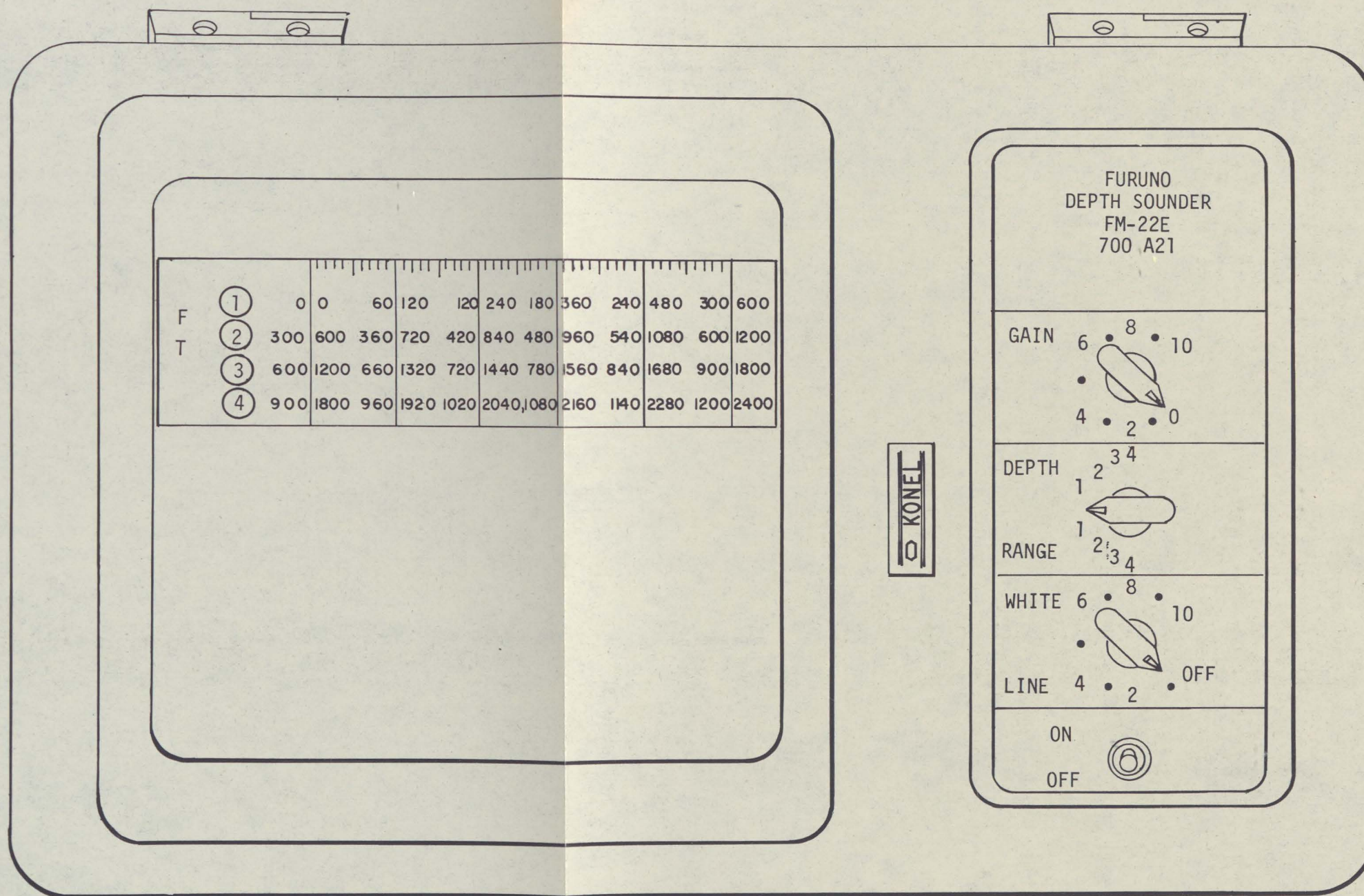

FIGURE 4-17. FATHOMETER DISPLAY (UNIT 700A21)

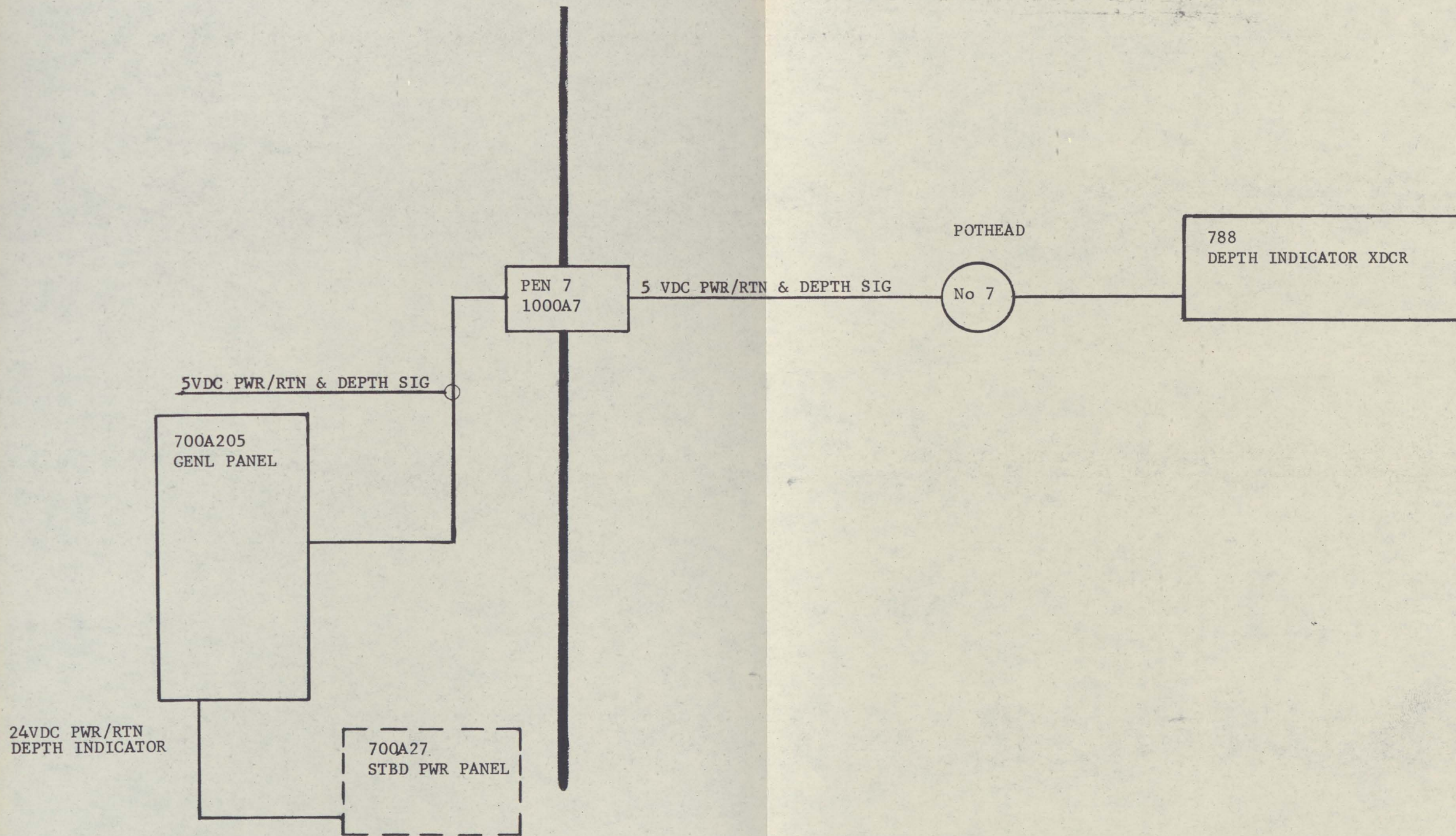

FIGURE 4-18. DEPTH INDICATOR SYSTEM

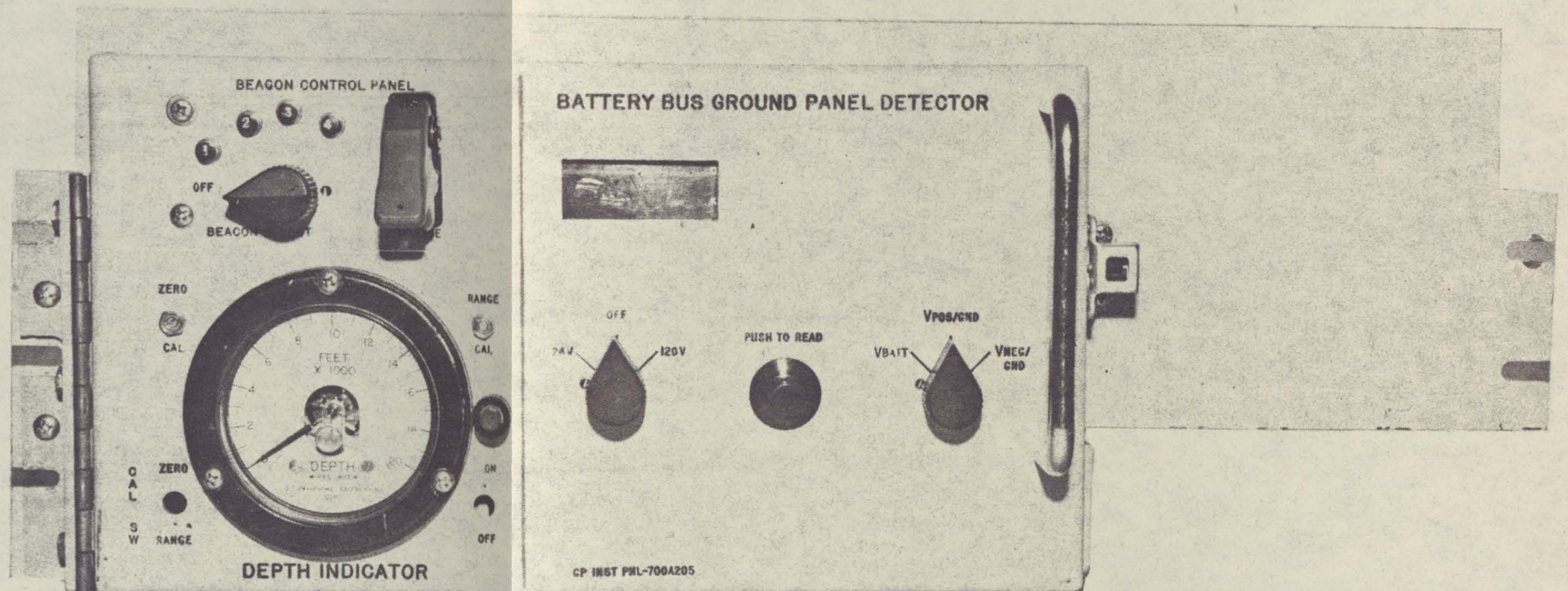

FIGURE 4-19. DEPTH INDICATOR DISPLAY

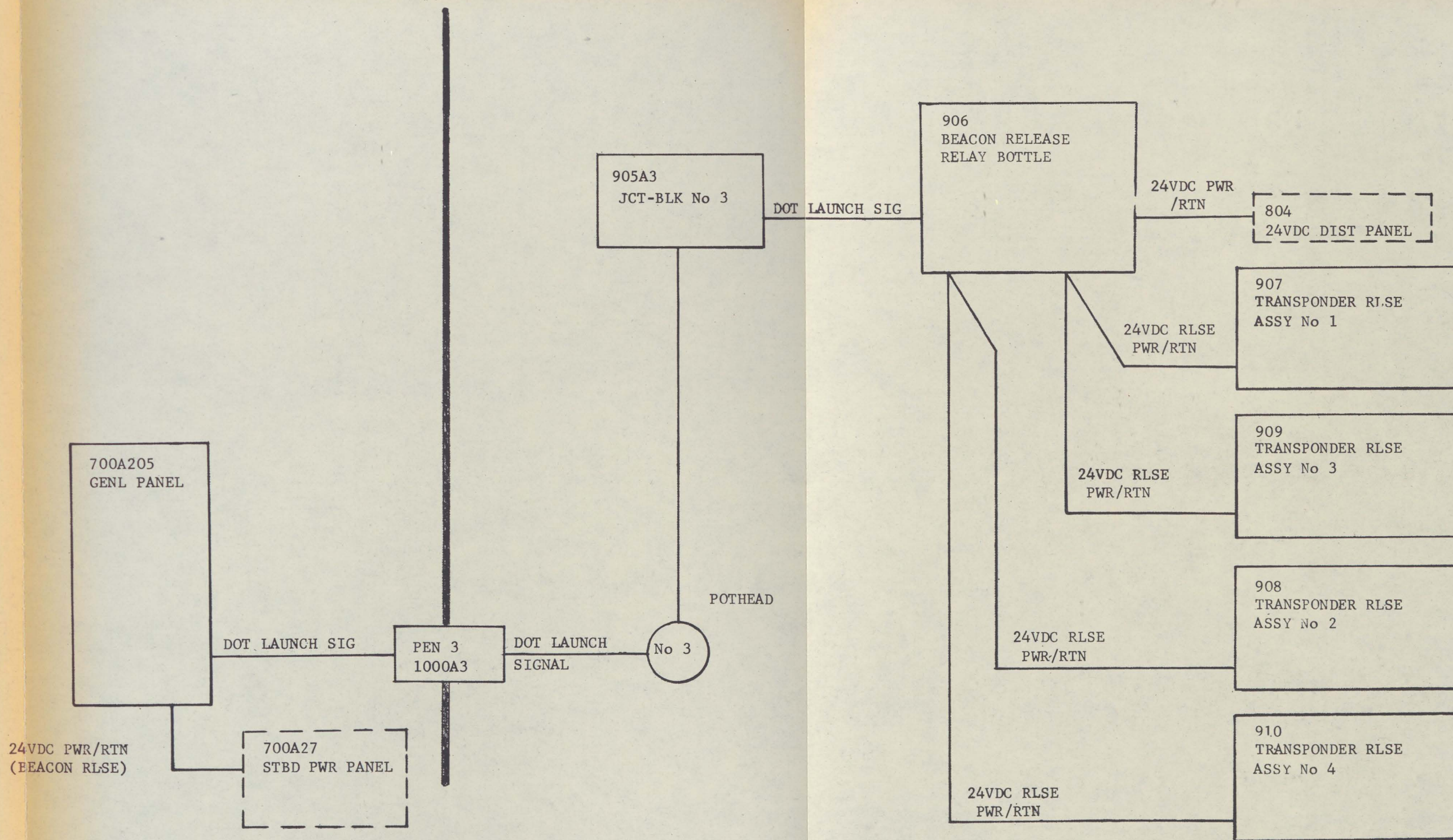

FIGURE 4-20. BEACON RELEASE SYSTEM

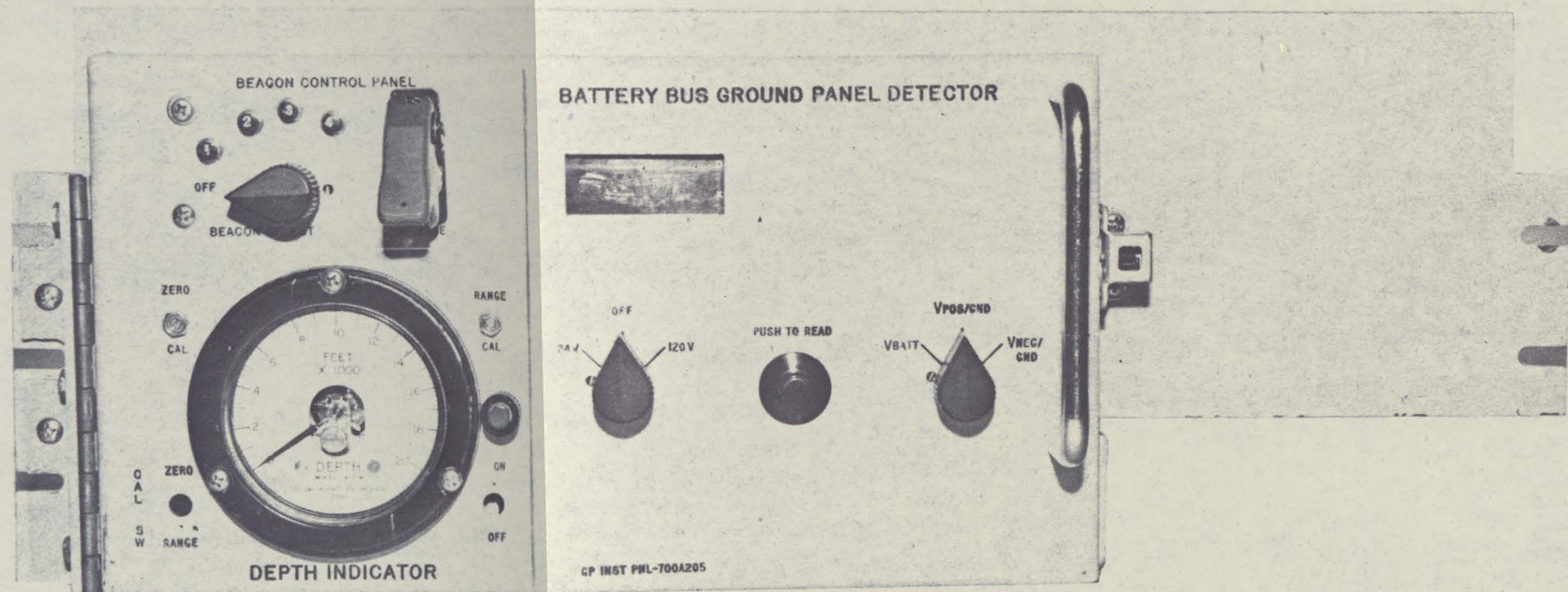

FIGURE 4-21 BEACON CONTROL PANEL

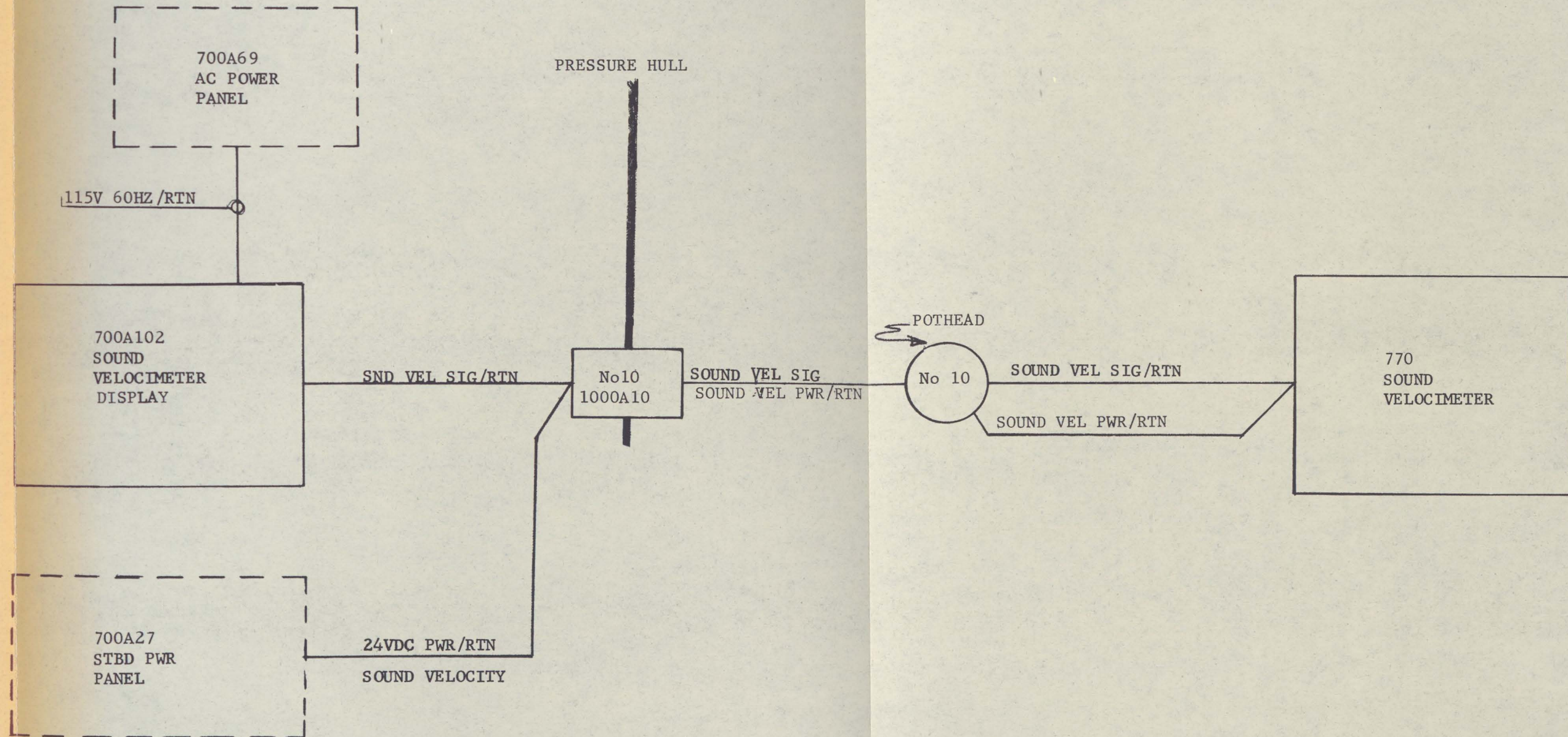

FIGURE 4-22. SOUND VELOCIMETER SYSTEM

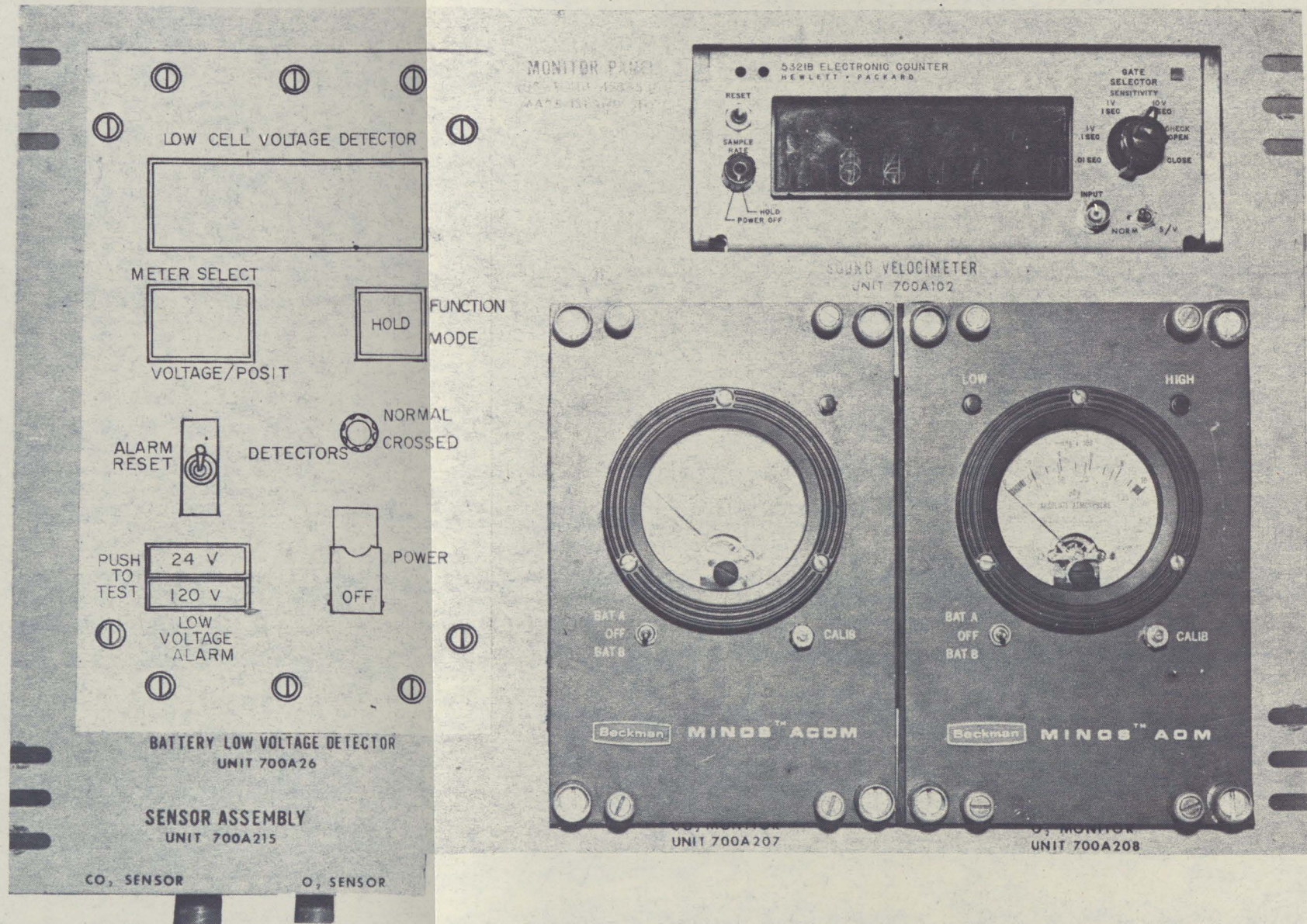

FIGURE 4-23. SOUND VELOCIMETER DISPLAY

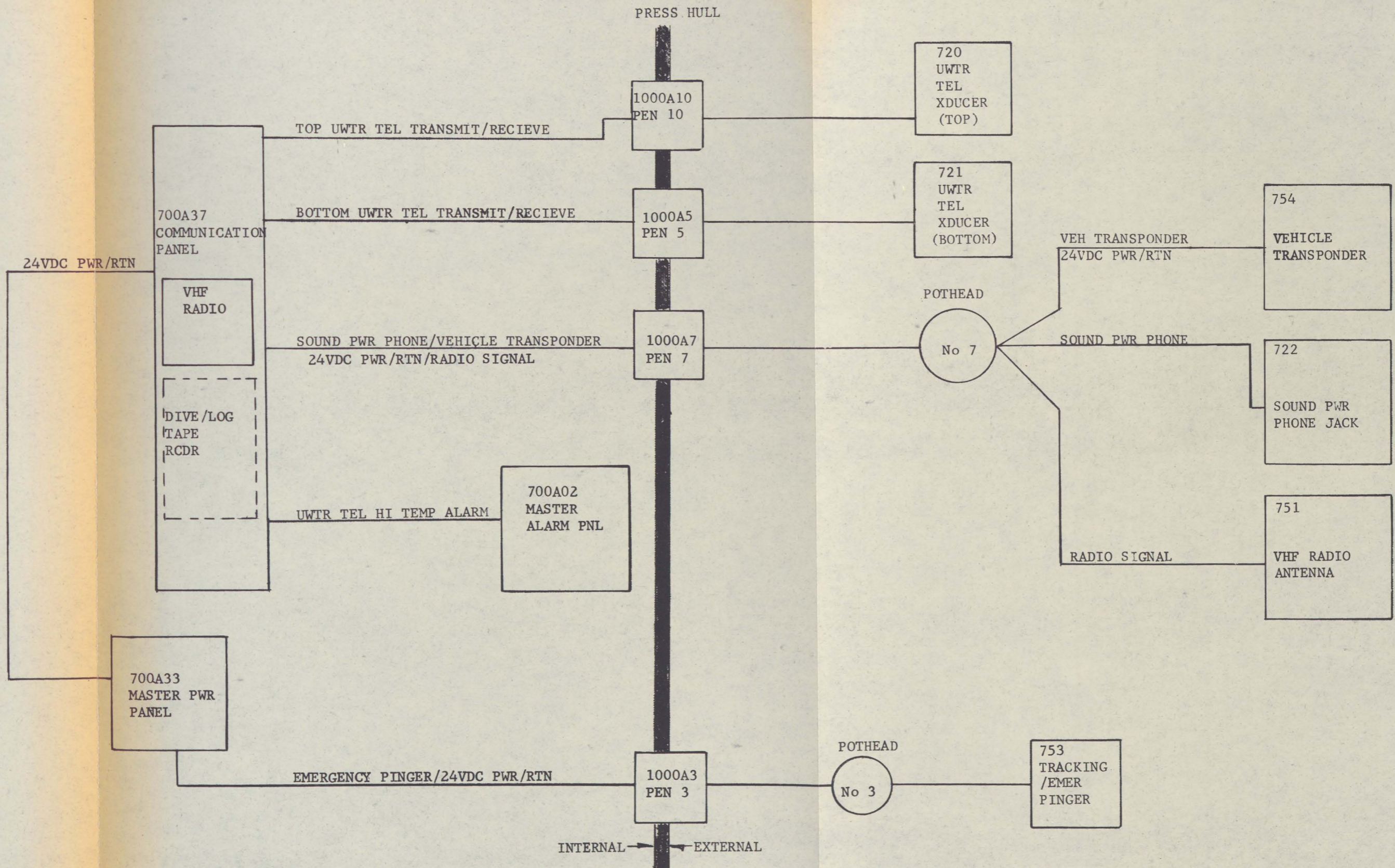

FIGURE 4-24. COMMUNICATIONS SYSTEM

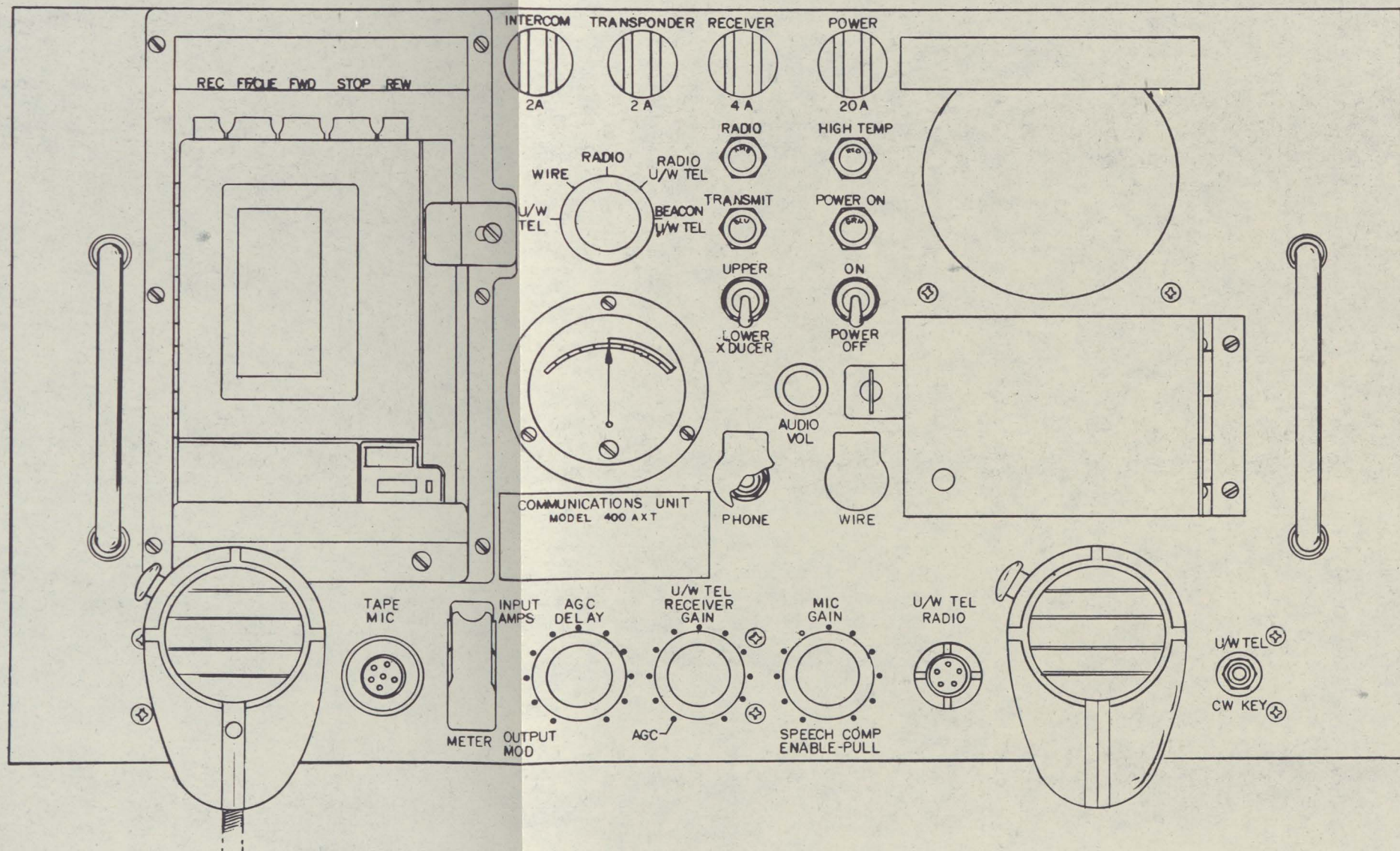

FIGURE 4-25. COMMUNICATIONS PANEL (UNIT 700A37)

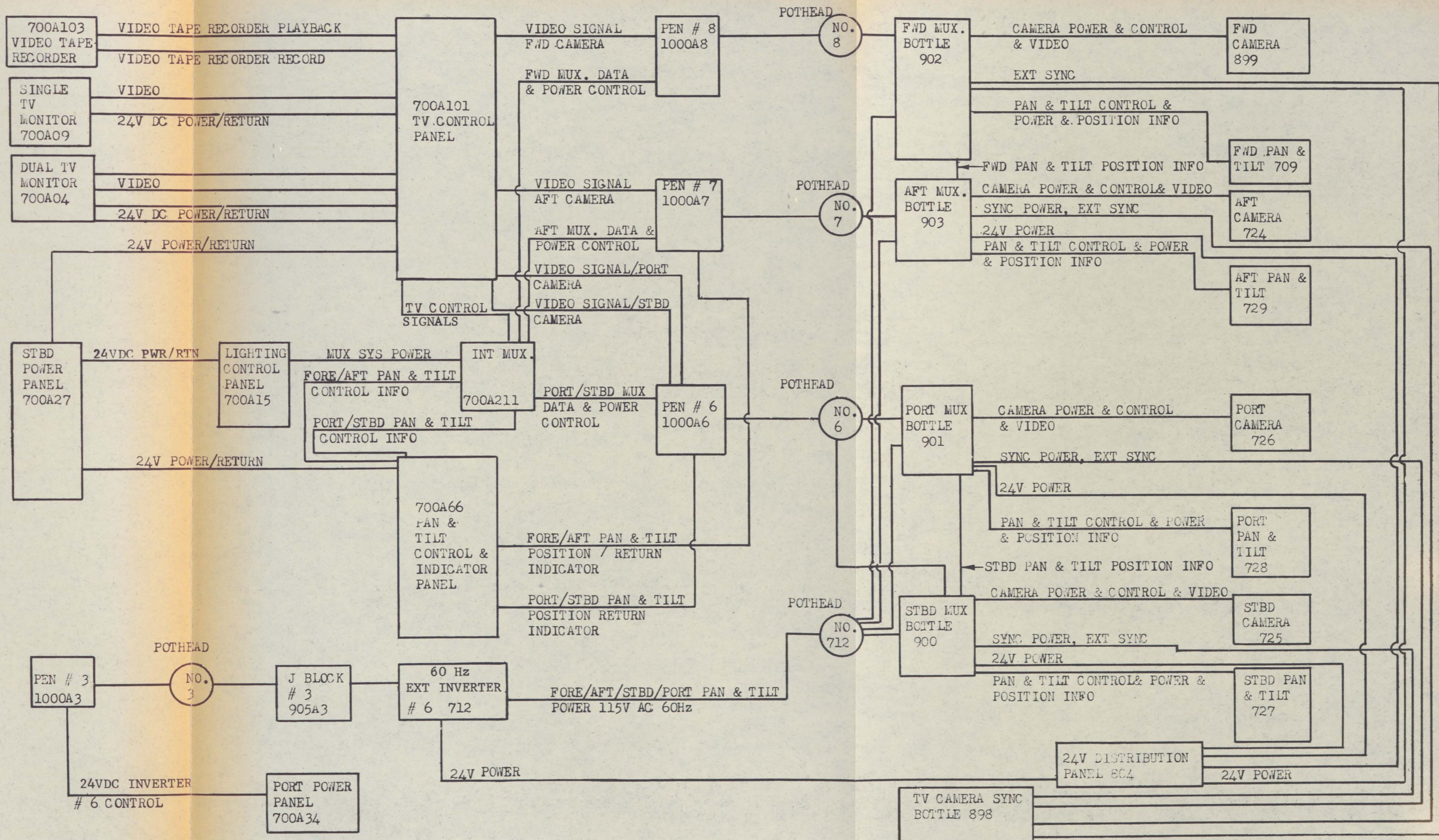

FIGURE 4-26. TV SYSTEM

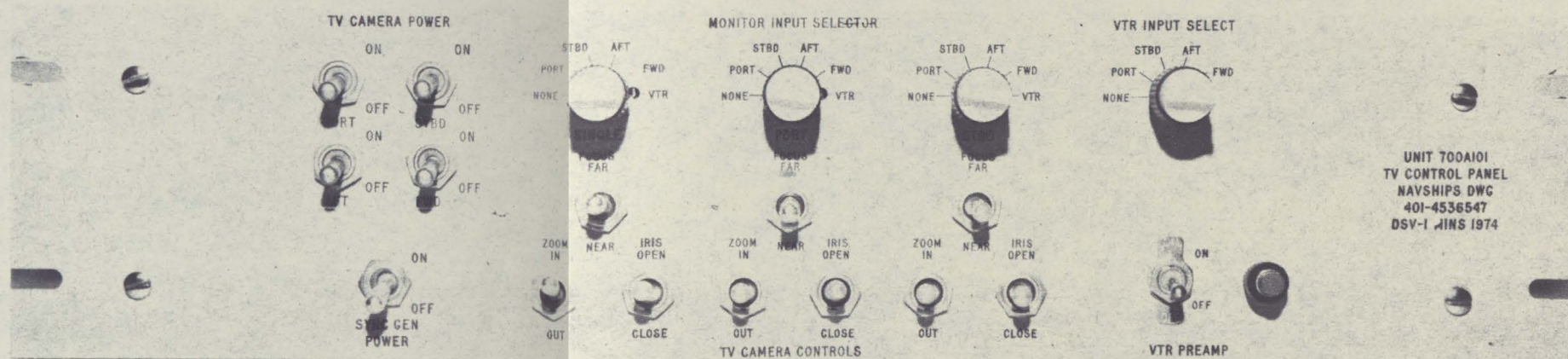

FIGURE 4-27. TV CONTROL PANEL

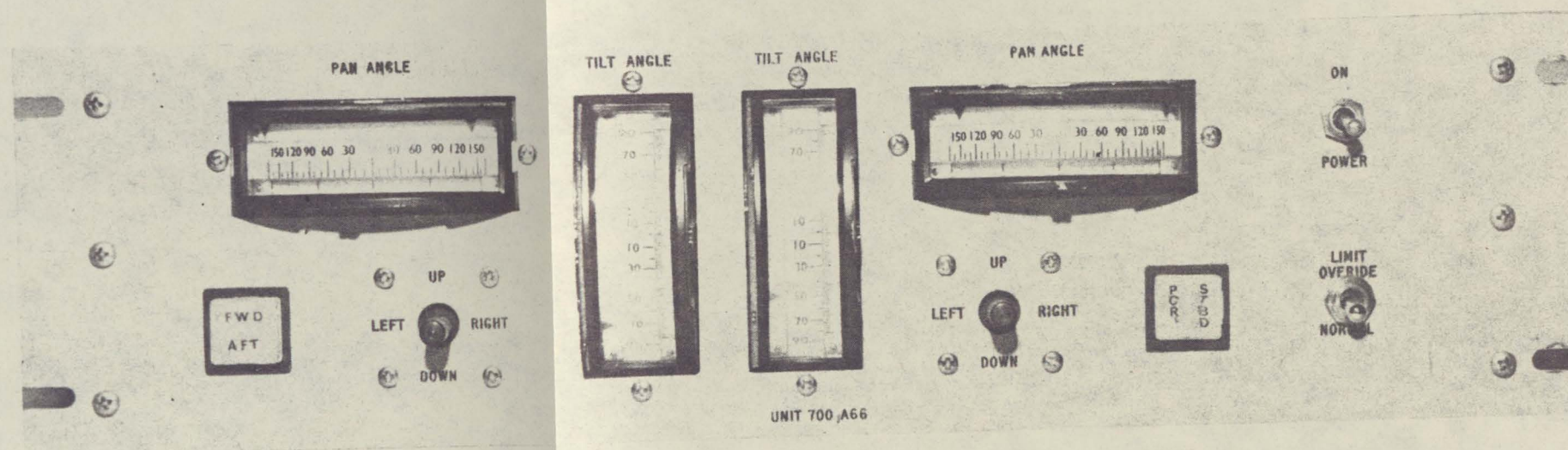

FIGURE 4-28. PAN AND TILT CONTROL PANEL

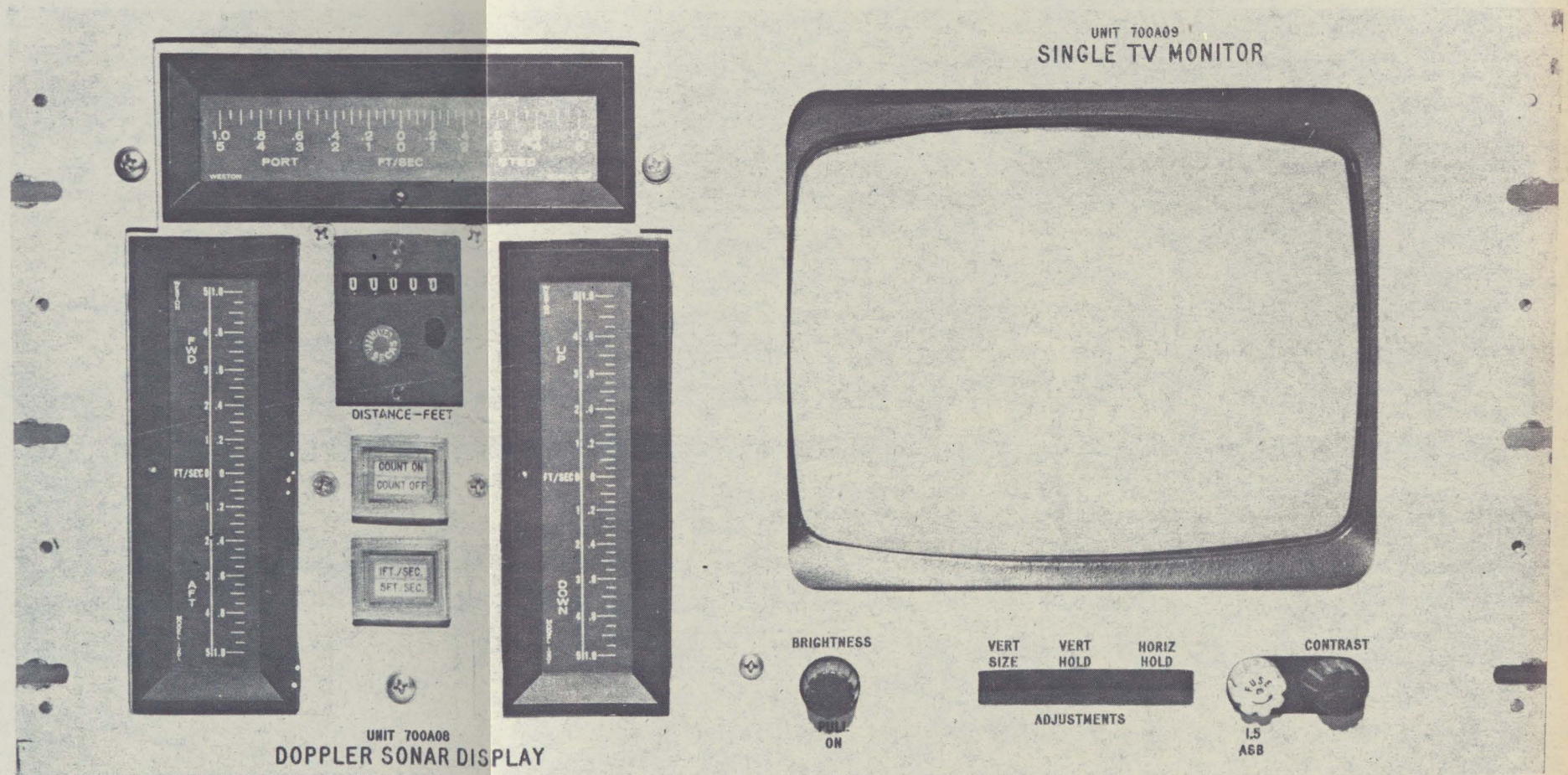

FIGURE 4-29 SINGLE TV MONITOR

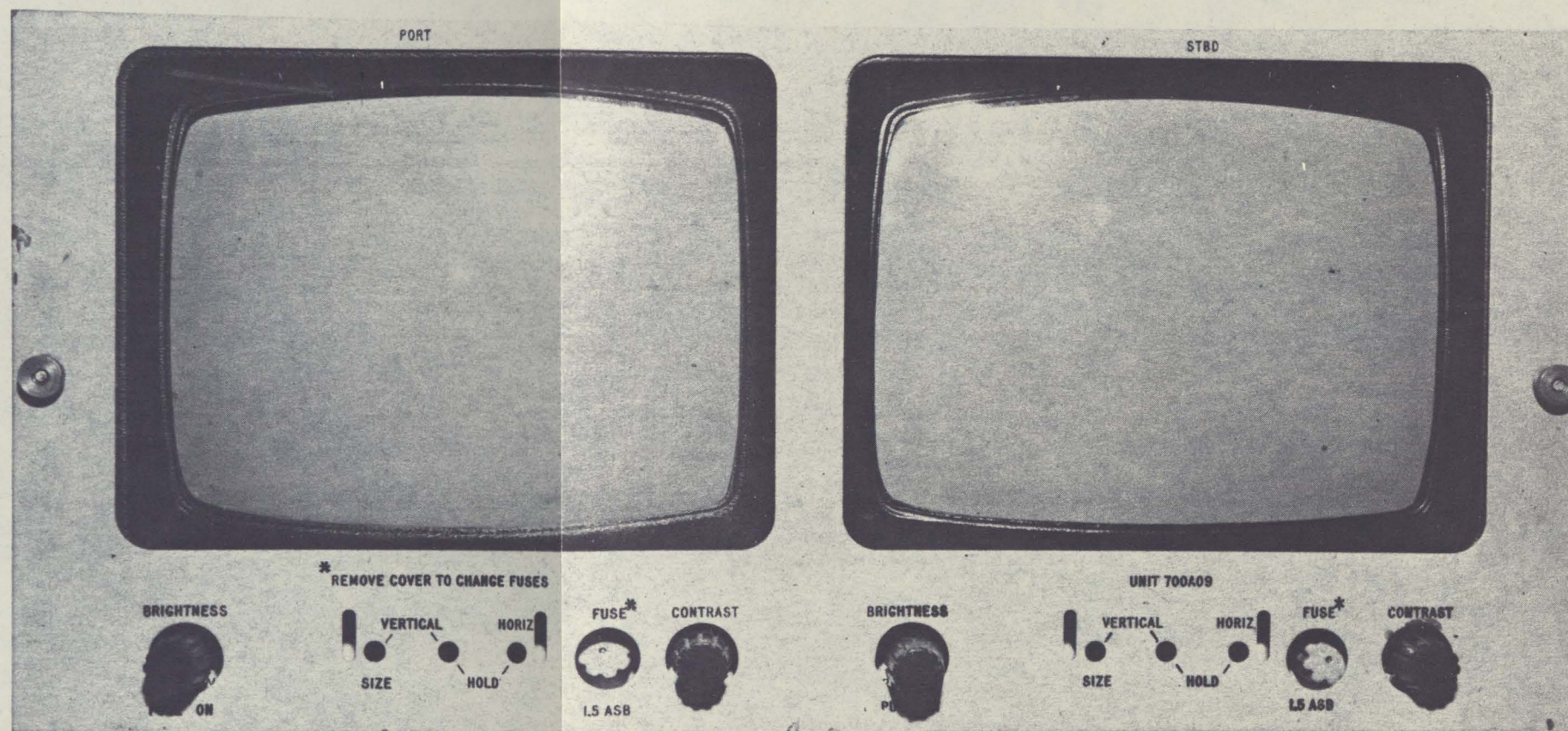

FIGURE 4-30. TV DUAL MONITOR - UNIT 700A04

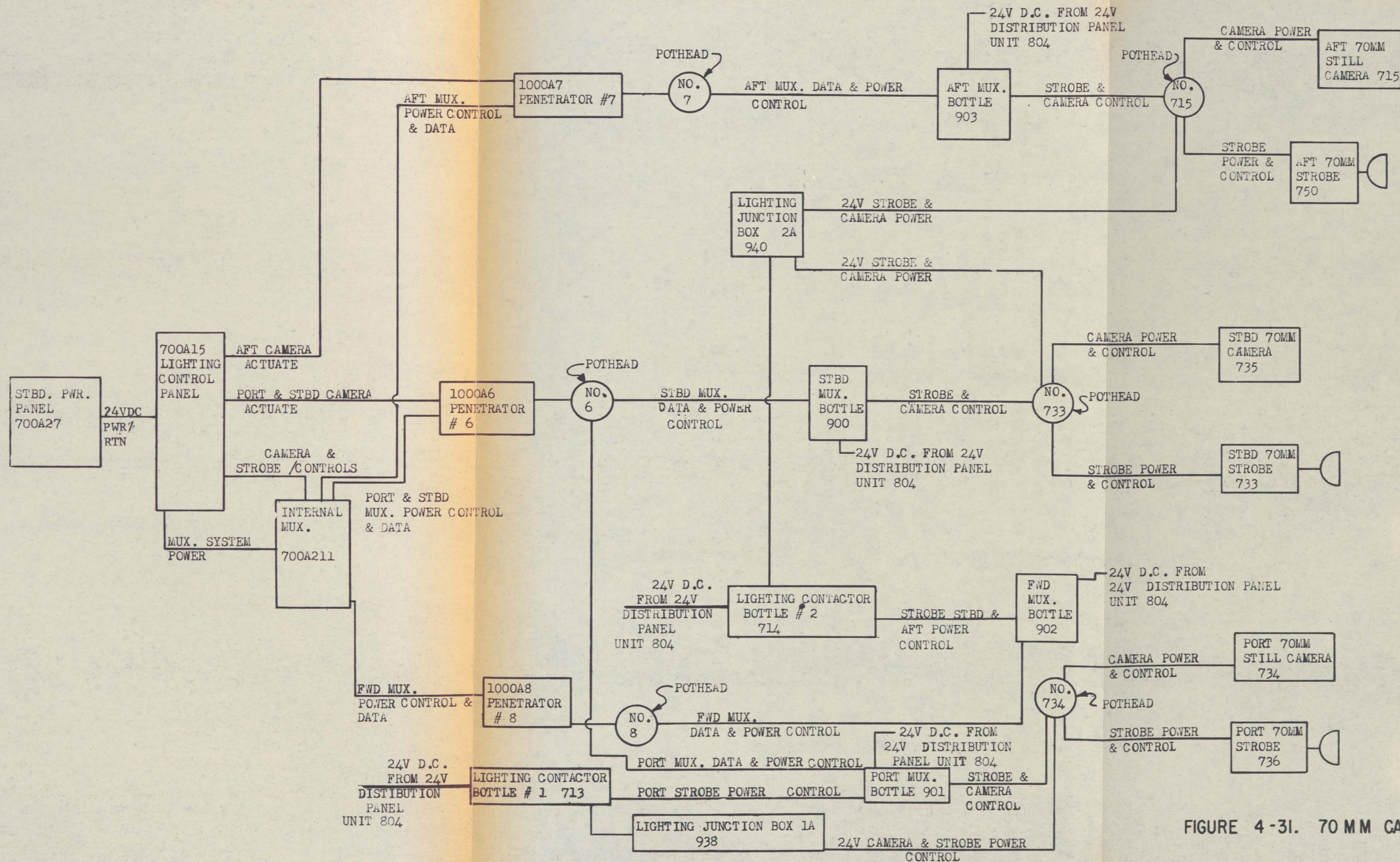

FIGURE 4-31. 70 MM CAMERA AND STROBE SYSTEM

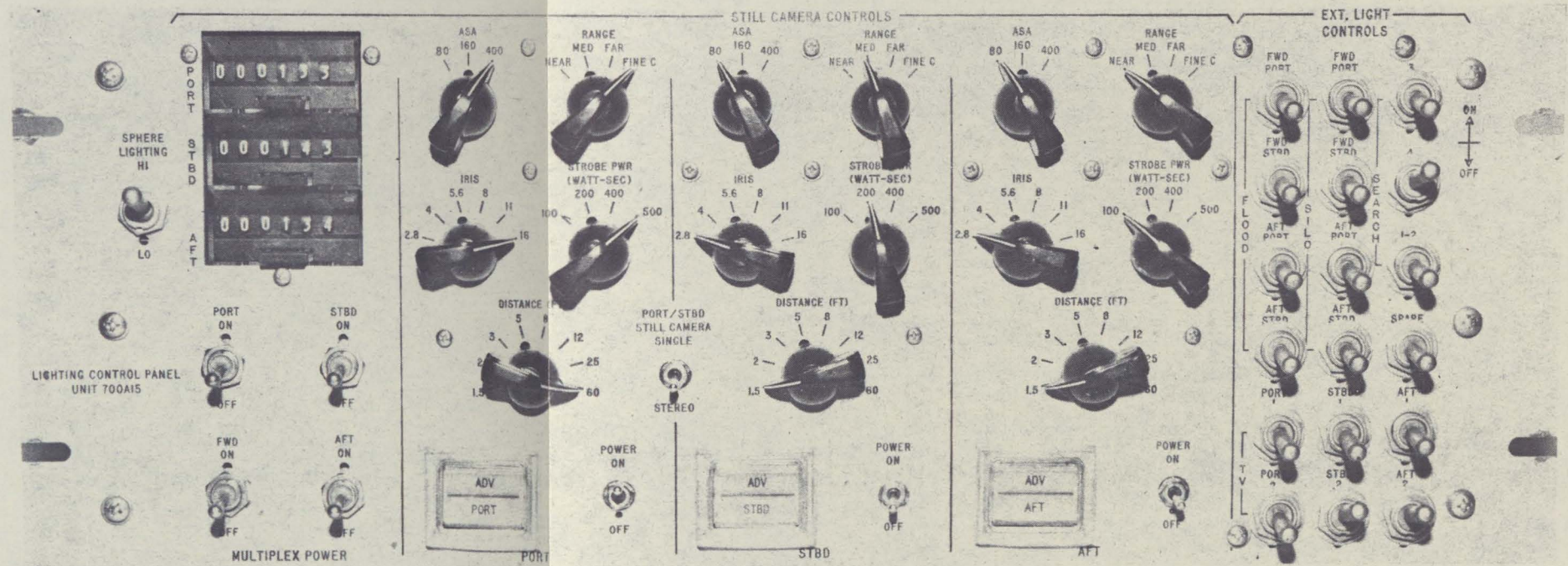

FIGURE 4-32. 7MM CAMERA CONTROL AND LIGHTING PANEL

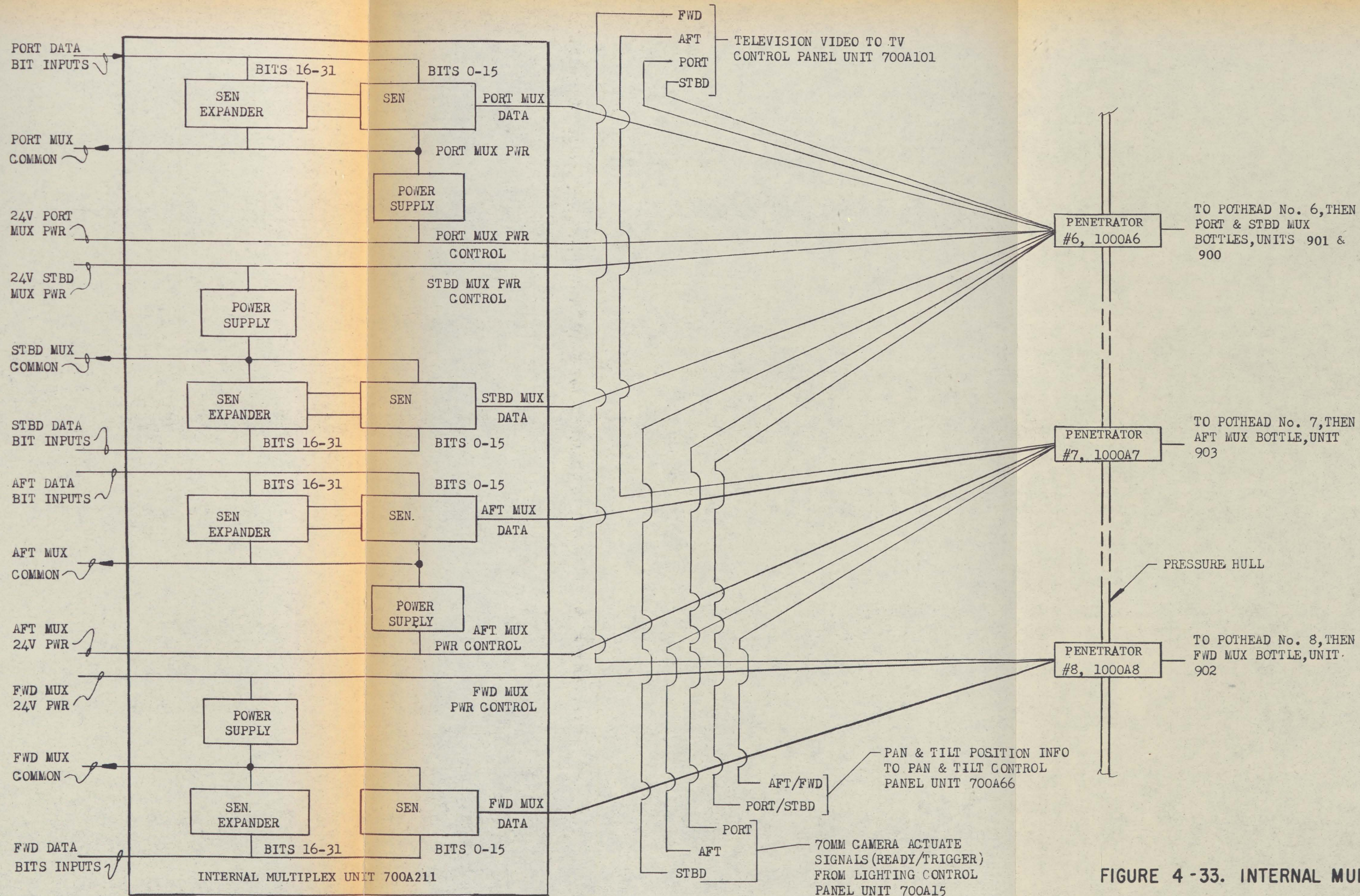

FIGURE 4-33. INTERNAL MULTIPLEX UNIT

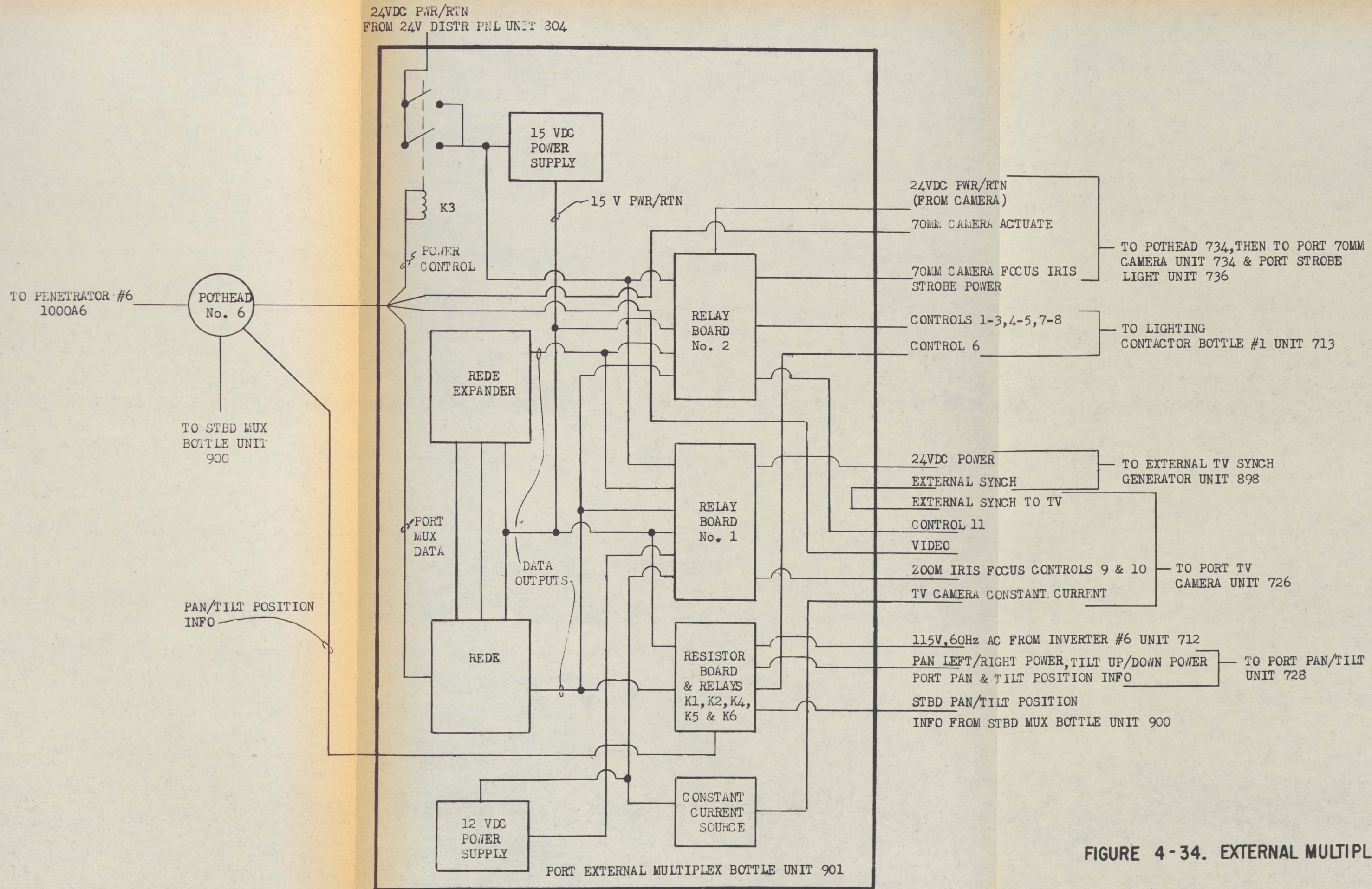

FIGURE 4-34. EXTERNAL MULTIPLEX BOTTLE (PORT)

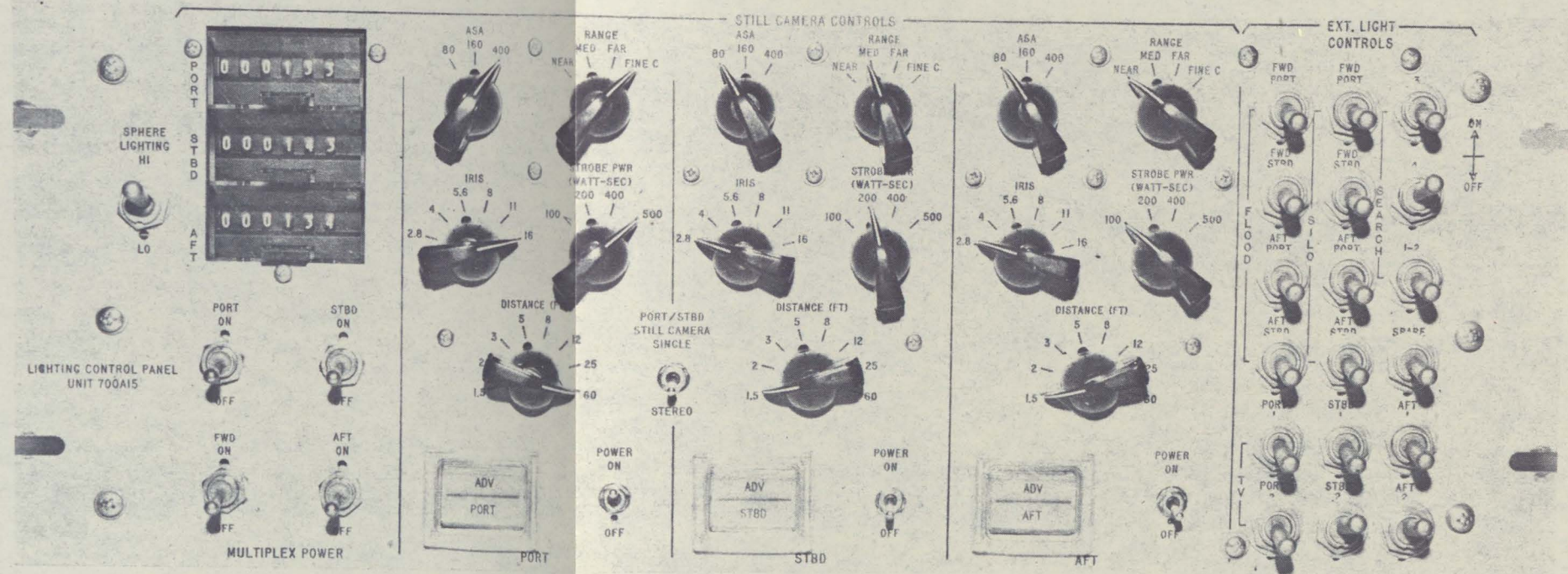
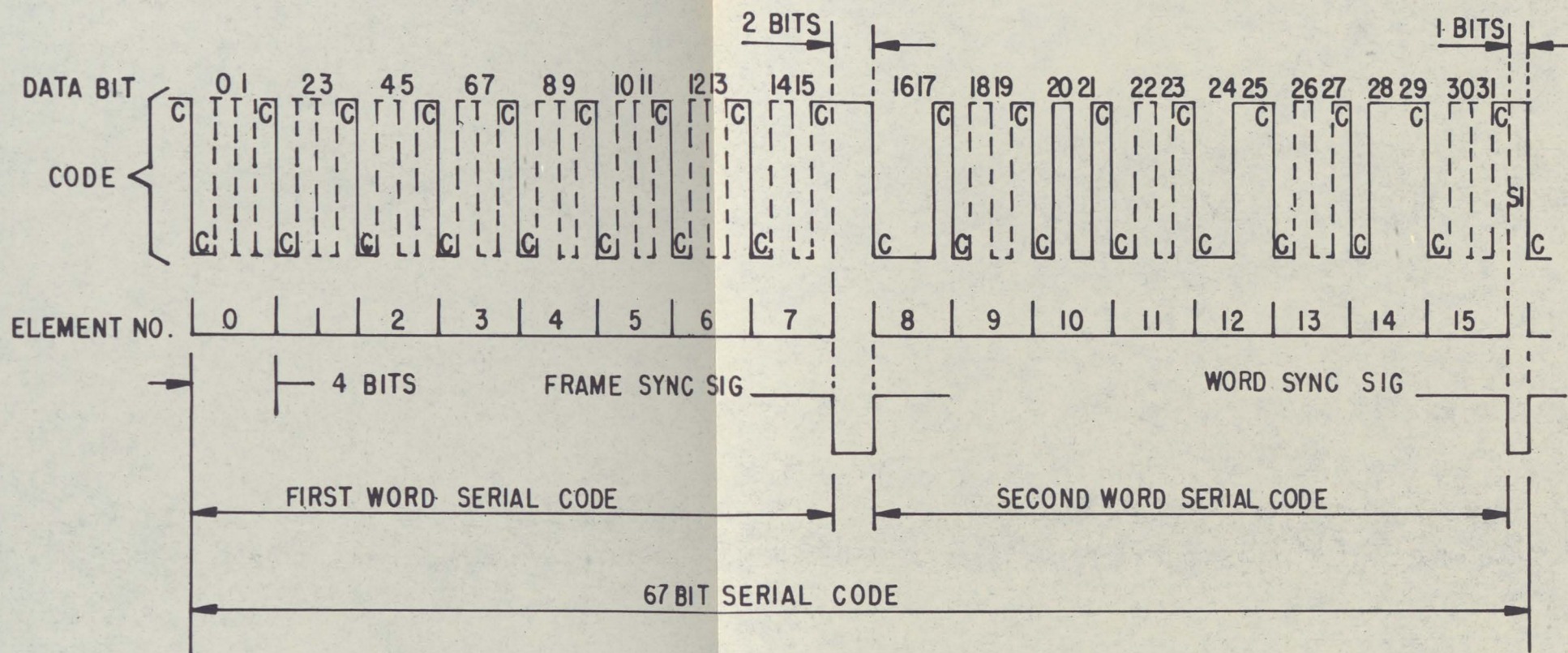

FIGURE 4-35. LIGHTING CONTROL PANEL (UNIT 700A15)
AND MULTIPLEX POWER CONTROL SWITCHES



NOTE: C-DENOTES CLOCK BIT

DO STATUS	DI STATUS	ELEMET NO. 0 CODE
OFF (D16)	OFF (D17)	
ON (D20)	OFF (D21)	
OFF (D24)	ON (D25)	
ON (D28)	ON (D29)	

FIGURE 4-36. MULTIPLEX 67 BIT SERIAL CODE

LIFE SUPPORT

CHAPTER 5
LIFE SUPPORT SYSTEM

Number		Page
5-1.	Introduction	5-1
5-3.	General Description	5-1
5-5.	Thermoelectric (T/E) Unit	5-1
5-13.	Oxygen (O ₂) System	5-3
5-17.	CO ₂ Removal Unit	5-4
5-21.	Atmospheric Monitoring Equipment	5-4
5-28.	Waste Disposal System	5-5
5-30.	Emergency Breathing System	5-5

CHAPTER 5

LIFE SUPPORT SYSTEM

5-1. INTRODUCTION.

5-2. This chapter provides a detailed functional description for each of the six systems comprising the Trieste II Life Support System. A list of publications related to the life support system is included as an appendix to this SIB, and is offered as a source of additional reference material.

5-3. GENERAL DESCRIPTION.

5-4. The main life support system provides a temperature and humidity controlled, one-atmosphere, air environment that supports 3 men for 41 hours. An emergency breathing capability is also provided in the sphere that supports 3 men for 23 hours. The six subsystems comprising the life support system include:

1. Thermoelectric Unit
2. Oxygen System
3. CO₂ Removal Unit
4. Atmospheric Monitoring Equipment
5. Waste Disposal System
6. Emergency Breathing System

5-5. THERMOELECTRIC (T/E) UNIT.

5-6. The air environment circulated through the cabin (sphere) absorbs heat and moisture from the personnel and equipment, and must be treated to maintain optimum operating conditions during a mission. This is accomplished by the T/E unit, which is rated at 10,400 Btu/hr and utilizes a direct water-to-air heat transfer to cool and dehumidify the air (Figure 5-1). The cabin air is drawn by the main fan into the T/E unit through a particulate and a carbon filter, which are used to remove bacteria, dust and odor. The air then passes into the core of the T/E unit over a series of fin and water tube assemblies. The fins absorb the heat, and the cooled and dehumidified air is then exhausted into the cabin through a diffuser. The T/E unit is located in Bay 6.

5-7. THERMOELECTRIC CORE. The core or heart of the thermoelectric heat transfer process for the T/E unit consists of six modular fin and water tube assemblies. Each water tube assembly consists of eight copper blocks with

holes through the center which are connected by stainless steel bellows. The bellows act as high electrical resistance joints and flexible water connectors. P- and N- type thermo elements (encapsulated bismuth telluride pellets) are soldered on opposing sides of the blocks and arranged in alternate positions throughout the core. These water tube assemblies are sandwiched between a number of air heat exchangers (fins), each of which bridges two pellets, one P and one N. With power applied, electrical current passes from P to N, a water block becomes a hot junction; and from N to P, a heat exchanger becomes a cold junction. With the six modules connected in this manner (thermoelectrically in series) the water circulated through the tubes absorbs the heat pumped by the pellets. Since the fins are connected to the water tubes through the pellets, the fins in turn absorb the heat from the air blown past them. A more detailed discussion of the thermoelectric process related to the unit is provided in Reference 5-1, the technical manual for the T/E unit.

5-8. The cabin heat absorbed by the fins, and in turn by the water in the tube assemblies is transferred by hoses to the hull heat exchangers. The hull heat exchangers (HHX) are mounted directly to the hull and serve as heat sinks for the T/E unit. The HHX material is 3/8-inch polyurethane which conforms to the hull surface and is bonded with epoxy. Since the entire hull surface, except for the HHX areas and bilge areas is covered with 1/4-inch insulation, highly efficient heat transfer is accomplished from the T/E unit and HHX through the steel and into the surrounding sea. The purpose of the hull insulation is to prevent condensation from collecting on the hull surface during missions and to insulate the personnel against excessive low temperature during an extended mission.

5-9. WATER SYSTEM. The primary function of the water system is to circulate the water which carries the heat away from the T/E unit and passes it into the HHX. The water system (Figure 5-1) consists of a pump, reservoir, filter, two check valves and isolating valves for the HHX. The majority of the water system components are mounted on the T/E assembly. The T/E assembly support brackets also act as water manifolds.

CAUTION

The water in this system is directly in contact with the negative bus of the electrical system of the T/E unit. This necessitates the electrical isolation of all components of the water system from the instrumentation cage to prevent grounding the electrical system.

5-10. The pump in the system provides 6 gpm at 23 psig and operates on 27 VDC. The T/E unit and pump are mounted with nylon-insulated hardware to ensure electrical insulation from the instrumentation cage. The reservoir, which is integral with the diffuser in the system, is connected directly to the pump inlet by a flexible hose. Its capacity is approximately one gallon. While the reservoir serves primarily as an expansion tank and not necessarily as a water replenishment supply, it has a water reserve of approximately

0.2 gallons. A "quarter-full" sight glass on the reservoir indicates the proper water level. Electrical isolation for the reservoir is achieved by containing the water in a nylon/chloroprene bag.

5-11. ENVIRONMENTAL CONTROL. Air temperature and relative humidity at the T/E unit intake are monitored by a thermometer, a hygrometer (relative humidity meter) and a temperature sensor. The meters indicate the temperature and relative humidity of the cabin air that is circulated through the electronics space (behind Bay 6). The T/E inlet air temperature sensor, set at 150 degrees F, is used as a protective device to deenergize the T/E unit in case of a malfunction.

5-12. The water system is equipped with a pressure sensor set at 5 psig and a temperature sensor set at 118 degrees F. The pressure sensor is used to deenergize the T/E unit in the case of water loss in the system, while the temperature sensor is used to deenergize the unit at high water temperature conditions due to low flow through the T/E unit. The water system also includes two check valves which are set at 10 psig and prevent the HHX from being overpressurized. One checkvalve bypasses the filter when the pressure drop exceeds 10 psig, due to clogging. The other check valve bypasses the paralleled heat exchangers if one or more is subjected to a 10-psig pressure differential due to clogging. In the bypass mode, flow would also continue through the unobstructed heat exchangers.

5-13. OXYGEN (O₂) SYSTEM.

5-14. The main oxygen system (Figure 5-2) supports 3 men for a period of 41 hours at an O₂ consumption rate of 0.5 liter per minute per man. The oxygen supply draws from two 730 in³ flasks of pure oxygen and automatically maintains an absolute pressure of 1 atm in the cabin by regulation of makeup oxygen. The O₂ supply and control system provides an automatically-controlled oxygen supply system for normal operation and a manually adjustable oxygen supply for emergency use only. The O₂ system requires no power and can operate under conditions of complete power failure.

5-15. O₂ SYSTEM COMPONENTS. The O₂ system components include two high-pressure gas flasks, a high-pressure regulator, a quick acting on-off valve, an absolute pressure controller (regulator), an emergency bypass metering valve, an O₂ filter and differential pressure gauge, and an oxygen flowmeter. In the event that the automatic control is not functioning properly, the absolute regulator can be bypassed manually by opening the bypass valve. This metering valve allows adjustment of the low-pressure oxygen supply to the desired level.

5-16. O₂ System Flow. The oxygen flow path is from the two 730 in³, 2250 psi oxygen flasks, located beneath the deck, to their respective shut-off valves and to the main (high pressure) regulator. At this point, the oxygen pressure is reduced to 75 psi and flows through the system on-off valve through a filter to the absolute gas pressure regulator and out the flowmeter. The meter is calibrated 0.75 to 5 slpm, equivalent to 1.5 to 10 scfh. This meter provides a visual check of proper system operation and permits manual adjustments to be

made in the event of automatic control system failure. The oxygen from the flowmeter outlet is mixed with the incoming air to the T/E unit in Bay 6 and exhausted through the diffuser into the cabin atmosphere.

5-17. CO₂ REMOVAL UNIT.

5-18. The carbon dioxide (CO₂) removal system consists of a parallel bank of three lithium hydroxide canisters and appropriate manifolding and two fans to continuously circulate the cabin atmosphere through the canisters. The system operates continuously rather than on a demand basis for highest reliability. The CO₂ removal unit absorbs CO₂ from the cabin atmosphere and the O₂ supply automatically replenishes with O₂ the volume of the CO₂ absorbed by the CO₂ removal unit.

5-19. The lithium hydroxide (LiOH) canisters are cylindrical in shape and hold an average of 6.3 lb of LiOH per canister. The inlets for the removal system are located on the lower center panel of Bay 6. The air is drawn from the cabin through these inlets, up through the canisters to the fan suction side, and blown out between the hull surface and the top mounting ring of the instrument cage. Only one of the two system fans is operated at a time, the other is available in case the operating fan fails. These fans are connected to the essential bus which can be supplied by either the normal 24-volt battery or the 24-volt essential battery. They are a separate circuit from the T/E unit and the main fan, and are transferred to the emergency power supply automatically if a power failure should occur.

5-20. The CO₂ exhaust is equipped with an air flow switch that actuates an audible and visual alarm at the Master Alarm Panel to indicate loss of flow. The CO₂ removal assembly is designed to absorb 0.15 lb of CO₂ per hour per man as an average over a 24-hour period. At this rate of production the level of concentration within the cabin should not exceed 1 percent. The chemical reaction of LiOH with CO₂ generates moisture and heat.

5-21. ATMOSPHERIC MONITORING EQUIPMENT.

5-22. When human life is to be sustained in a closed atmosphere, it is important to monitor and control the partial pressure of a number of atmospheric gases. The most important gases are oxygen and carbon dioxide. For relatively short missions where the buildup of other toxic or noxious gases is not a significant factor, these may be the only constituents measured.

5-23. OXYGEN MONITORING. The Cabin O₂ level is continuously monitored by a Beckman Minos Atmospheric Oxygen Monitor (AOM). This instrument has adjustable high and low O₂ level setpoints which are connected to the Master Alarm Panel "O₂/CO₂ BAL" indicator and horn. The high level setpoint is presently set at 23.0 + 0, -0.5% O₂ and the low level setpoint at 17 + 0.5, -0% O₂. The AOM is powered from the Master Power Panel and has internal batteries with a front panel transfer switch for backup use. The AOM sensor

is mounted just below the monitor panel. A backup O₂ monitor (Biomarine) is installed on the Master Alarm Panel. It uses no external power, has no alarms, batteries or on-off switch. It runs continuously.

5-24. CO₂ MONITORING. The cabin CO₂ level is continuously monitored by a Beckman Minos Atmospheric Carbon Dioxide Monitor (ACDM). This instrument has an adjustable high CO₂ level setpoint (set at 1% CO₂) which is connected to the Master Alarm Panel "O₂/CO₂ BAL" indicator and horn. The ACDM is powered from the Master Power Panel and is also equipped with internal batteries and a front panel power transfer switch for backup use. The ACDM sensor is mounted just below the monitor panel. An alternate (backup) CO₂ monitoring capability is provided which consists of intermittent sampling with a hand operated pump (Draeger) through colorimetric indicator tubes.

5-25. CABIN TEMPERATURE. A continuous indication of cabin temperature is provided using a bimetallic thermometer (Trecce) which is located in the T/E unit inlet stream. The thermometer readout is mounted in the Life Support Power Control Panel.

5-26. CABIN HUMIDITY. A continuous indication of cabin humidity is provided using a mechanical hygrometer (Bacharach) which is located in the T/E unit inlet stream. The hygrometer readout is mounted in the Life Support Power Control Panel.

5-27. CABIN PRESSURE. Cabin pressure is continuously displayed by an altimeter which is mounted in the Gyro Repeater and Indicator Panel.

5-28. WASTE DISPOSAL SYSTEM.

5-29. The waste disposal system for the vehicle currently consists of bottles and plastic bags which are used by the crew during a mission.

5-30. EMERGENCY BREATHING SYSTEM.

5-31. GENERAL. The emergency breathing system (Figure 5-3) provides a pure oxygen source for three personnel in the event of main life support system malfunction or if the cabin atmosphere becomes contaminated by smoke or gas. Emergency breathing is provided through full-face masks by a closed-circuit recirculating system which uses lithium hydroxide (LiOH) to remove carbon dioxide. The face masks also provide eye protection against a contaminated atmosphere. The system is designed to supply 3 persons for 23 hours.

5-32. SYSTEM COMPONENTS. Pure oxygen for the system is contained in a single 730 in³ gas flask pressurized to 1800 - 2250 psi. The components of the emergency breathing system include a pressure regulator which supplies oxygen at 50 psi to the low pressure system; a 0 to 10-cfh flowmeter; a metering jet; a bail-operated demand valve inside the inhalation breathing bag; an exhalation bag; two LiOH canisters; an overhead manifold; three manifold mounted valves; and three full-face (oral-nasal) breathing masks.

5-33. SYSTEM OPERATION. In normal EBS operation (Figure 5-3) oxygen flows through the flask valves and the high pressure system valve into the pressure regulator. Here the pressure is reduced to 50 psi and delivered to the low pressure system. Oxygen then passes through a metering jet which provides a constant flow into the inhalation bag at a rate approximately equal to the oxygen consumption of two men engaged in light activity and a third man inactive. Oxygen is drawn through the inhalation manifold and through check valves into the face masks.

5-34. The exhaled gas passes through the other check valves into the exhalation manifold and then into the exhalation bag. CO_2 is scrubbed from the exhaled gas as it passes through the LiOH on its way to the inhalation bag. If the constant flow of oxygen is not enough, the inhalation bag deflates, actuating a bail-operated demand valve which allows oxygen to inflate the inhalation bag. A manual bypass valve can also be used to increase the flow of oxygen into the inhalation bag. The inhalation and exhalation bags each hold 8.3 liters of gas. Normal oxygen percentage of the breathing gas in the system ranges from 40% to 80% O_2 depending on the amount and frequency of system purging.

5-35. The EBS inhalation and exhalation manifolds are located directly above the crew and extend half-way around the instrument cage. On-off valves are mounted on the manifolds and are connected to the manifold outlets by flexible hoses. The on-off valves allow the individual user to purge the EBS and also, to shut off the system from the cabin atmosphere when not in use. The manifold mounted EBS on-off valves are connected to the face masks by flexible hoses. The hoses and mask combinations are stored in nylon bags with a snap fastening flap. The bags are secured on the manifolds so that when the snap is pulled and the flap is opened, the mask and hoses fall into the user hands.

5-36. EMERGENCY BREATHING SYSTEM (EBS) COMMUNICATIONS. Each EBS mask is provided with a dynamic microphone installed in the oral-nasal cup. The microphone is wired to a coaxial feed-through in the mask hose adapter tee and an adapter cable to interface with the microphone jack on the 400 AXT communications panel. The adapter cable contains the necessary interfacing connectors as well as a push-to-talk switch on a coil cord. Only one of the crew may connect his EBS mask adapter cable to the communications panel at a given time. Once connected, he may transmit normally using the EBS mask microphone and the adapter cable push-to-talk switch.

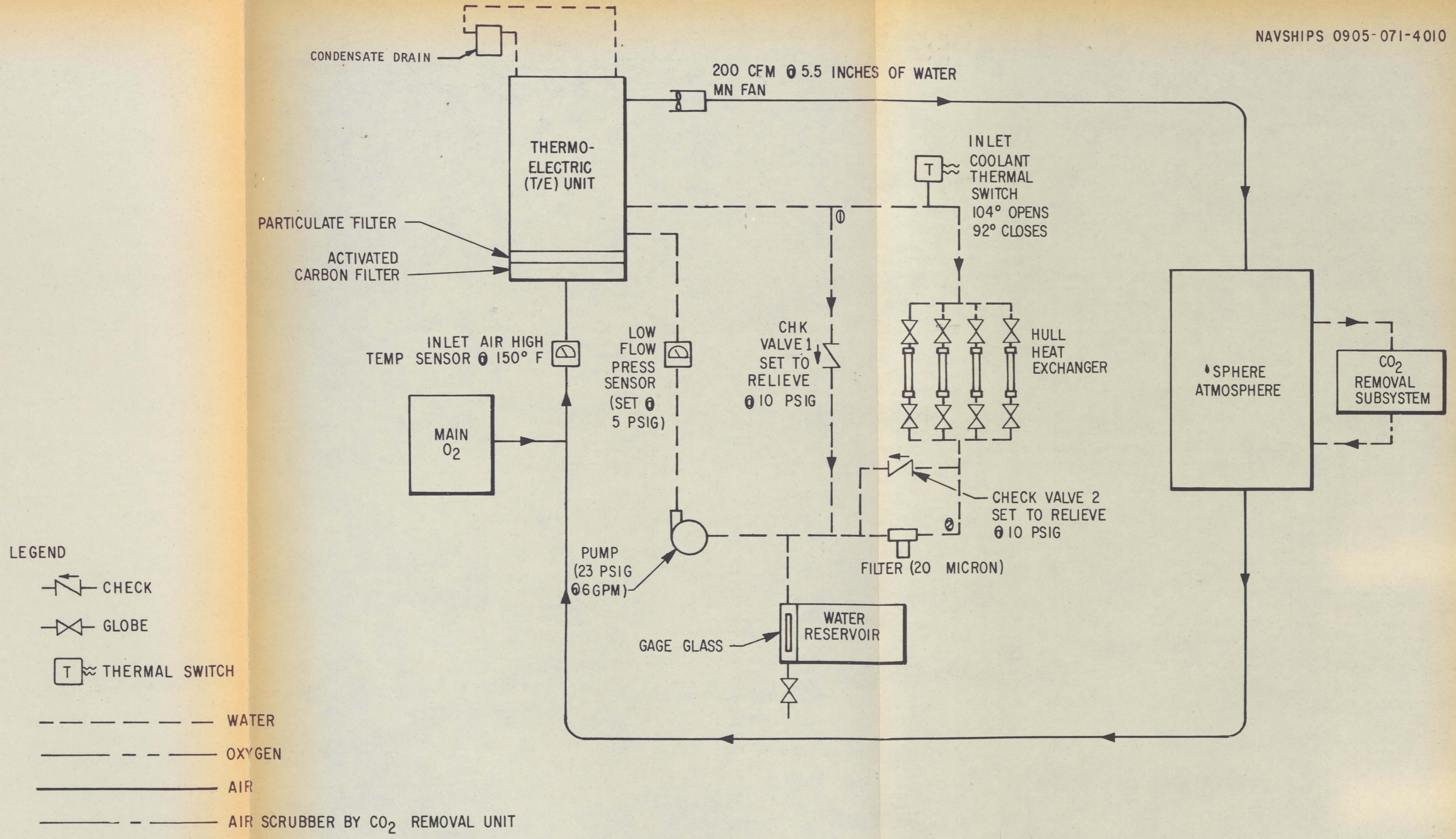

FIGURE 5-1. LIFE SUPPORT SYSTEM WITH THERMOELECTRIC UNIT

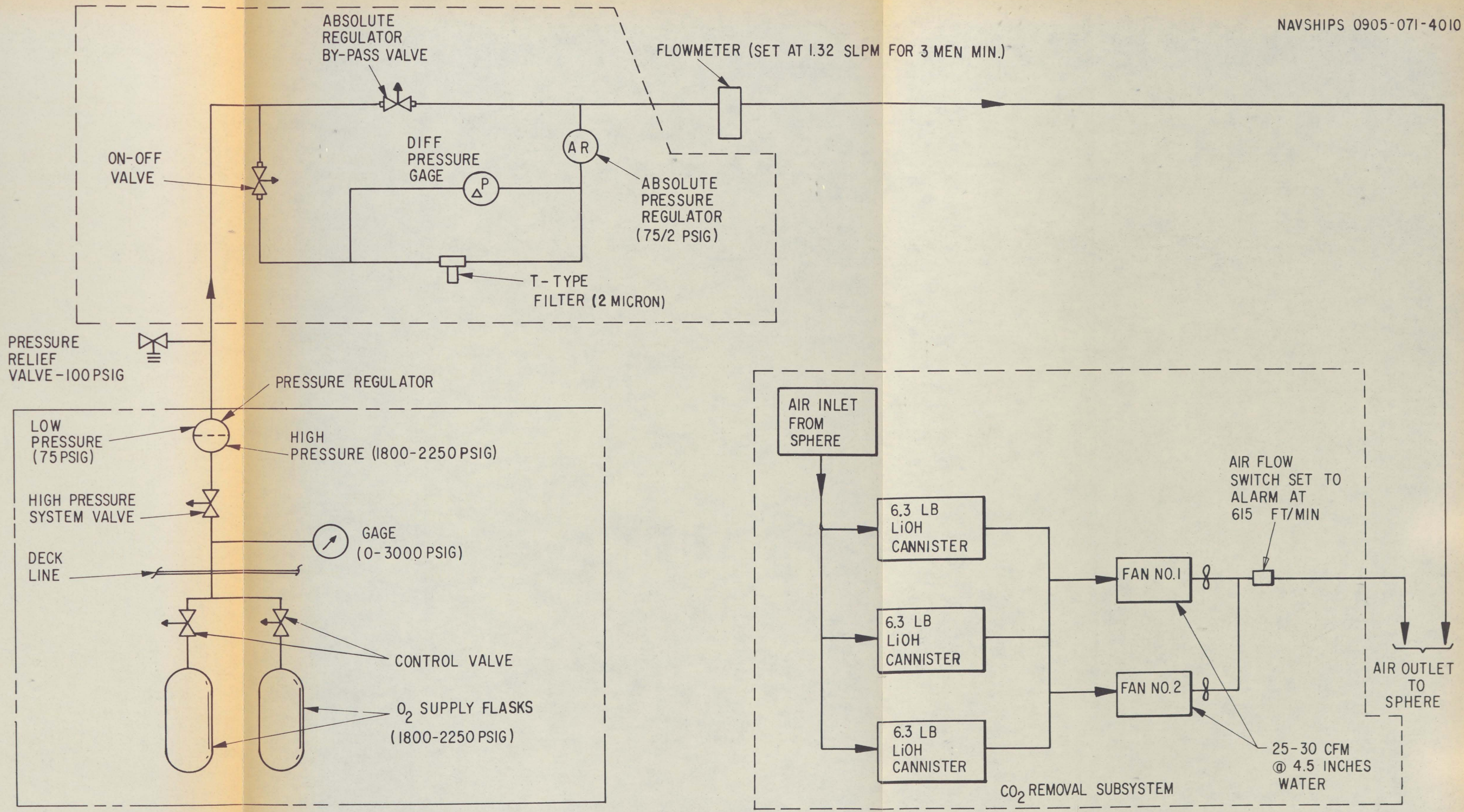

FIGURE 5-2. MAIN O₂ SYSTEM

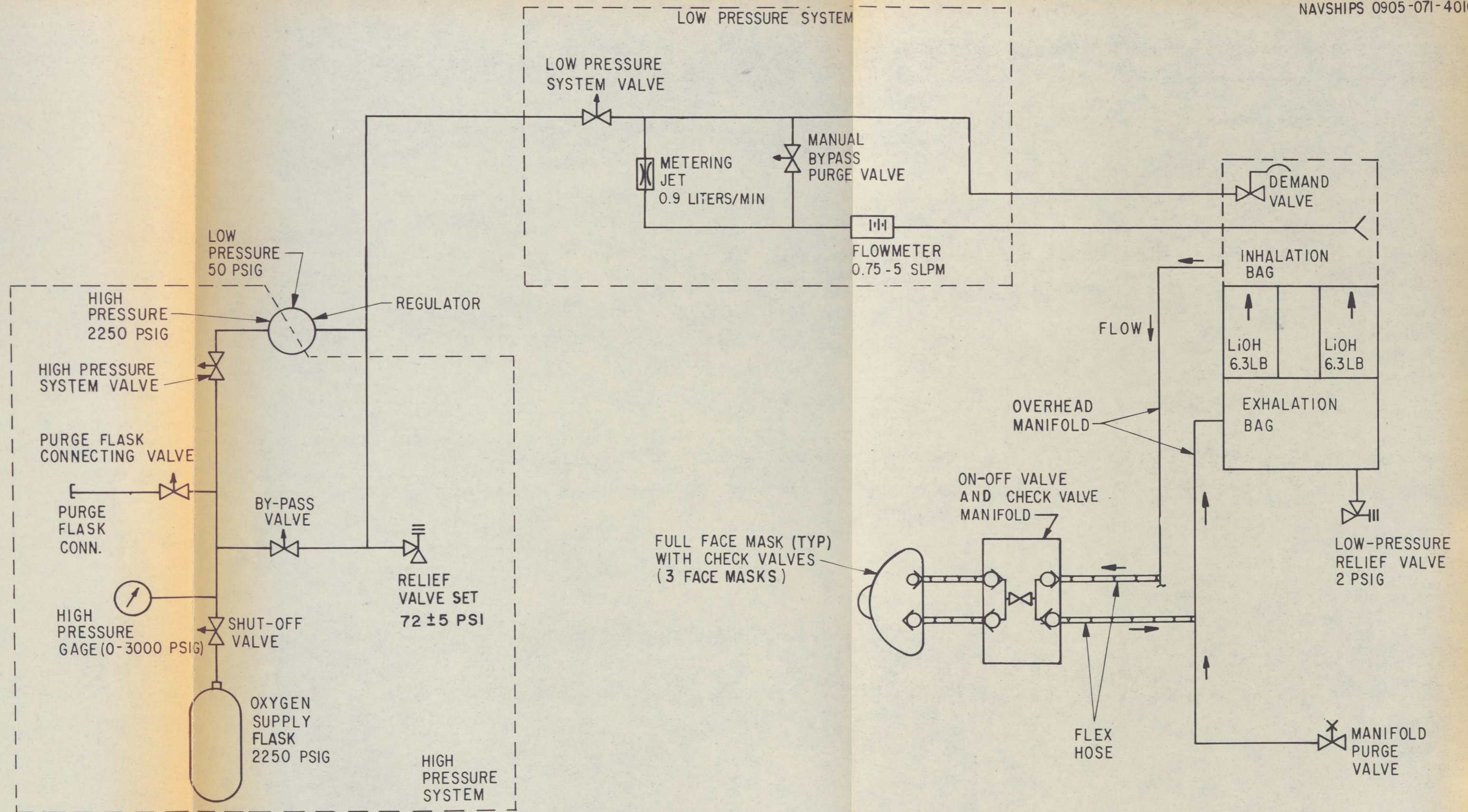

FIGURE 5-3. EMERGENCY O₂ SYSTEM

44

HULL & MACHINERY

CHAPTER 6

HULL AND MACHINERY

Number		Page
6-1.	Introduction	6-1
6-3.	Sphere	6-1
6-16.	Float Construction	6-3
6-18.	Superstructure	6-3
6-24.	Fairwater	6-4
6-28.	Reach Rods and Operating Gear	6-4
6-33.	Foundations	6-5
6-37.	Tripping Levers	6-5
6-44.	Battery Boxes	6-6
6-48.	Stabilizers	6-7
6-52.	Propulsion	6-7
6-58.	Bow Winch	6-8
6-62.	Trail Ball Winch	6-9
6-73.	Manipulator Arm	6-10
6-84.	Fire Fighting Equipment	6-12

CHAPTER 6

HULL AND MACHINERY

6-1. INTRODUCTION.

6-2. This chapter describes the structural characteristics of the sphere, float, superstructure, foundations and stabilizers that comprise the Trieste II. A functional description of the machinery components of the vehicle, including reach rods, operating gear and tripping lever devices, is also provided. A list of drawings and publications related to the hull and machinery is included as an appendix to this SIB.

6-3. SPHERE.

6-4. GENERAL. The sphere consists of steel hemispherical units that are mated and clamped together to form the operators compartment (cabin). The two HY-120 steel hemispheres, along with two clamp rings and the hatch were forged and rough machined, and completely ultrasonically inspected for material defects. Chemical and physical tests were also conducted to verify the composition and strength of the hemispheres. After final finish machining, the sphere halves were checked for circularity and ultrasonically checked for thickness. The fully assembled sphere was fitted with strain gages and hydrostatically tested to 22,000 foot submergence pressure. A spherical shape was used for the operators compartment because its inherent characteristics make it the most efficient pressure resistant shape.

6-5. HEMISPHERICAL UNIT. The mating surfaces of the hemispheres extend approximately 15/16 of an inch behind the outer surface of the sphere. These flanges are 1-inch thick and provide a clamping surface for the two clamp rings. The rings are held together with (48) 3/4-inch bolts, nuts and key washers. Each mating surface has a continuous circular groove for three CRES CL-304 guide ring segments. The segments are pressed into the lower hemisphere and engage the groove in the upper hemisphere at assembly. These rings are used to align the two hemisphere segments, as well as providing resistance to shearing forces on the sphere joint. There is an additional concentric circular groove (outside of the guide ring) which is machined into the mating surface of the lower sphere segment. An "O" ring in this groove provides watertight integrity.

6-6. HATCH. The hatch is a forged truncated cone, machined and lapped to exactly fit a socket cut in the sphere wall. A peep hole, as described in paragraph 6-7 is centered in the hatch, and a low pressure gasket with a retaining ring is installed on the perimeter of the hatch. The hatch is secured from the inside by means of a dog. An exterior jacking device is provided to jack the hatch open from the outside in an emergency condition. A torsion

spring assembly is provided to hold the hatch in a slightly open position when the dog is released. The design requires a minimum amount of pressure to seat or fully open the hatch.

6-7. WINDOWS. The viewing port and two peep holes are fabricated from Plexiglas G, a thermoplastic acrylic resin with high grade optical qualities, and excellent weather and impact resistant properties. Plexiglas is dimensionally stable and can safely withstand temperatures of up to 200 degrees F. The viewing port and peep hole windows are 90-degree truncated cones and are machined and lapped to fit sockets in the sphere wall.

6-8. A low-pressure synthetic rubber gasket and a CRES CL-304 retaining ring are installed around the perimeter of the Plexiglas and secured to the sphere by 1/4-inch hexagonal head machine screws. The conical shape and lapped fit of the windows provides the necessary high-pressure seal.

6-9. PENETRATORS. Eleven penetrators are installed in the upper hemisphere in two concentric circles, five in each circle plus one in the center. The penetrator holes are 1.976 inches in diameter by 1 9/16 inches deep, tapering at 40 degrees to a 1-inch diameter hole through the sphere wall. Tapered Lucite sleeves, which fit over the shanks of the penetrators and seat on the taper in the bores, form the high pressure seal. The penetrator flanges are secured to the sphere with six 1/4-inch K-Monel studs.

6-10. SPHERE INSTALLATION. The sphere is secured in place in the sphere recess by means of two diagonal straps. These straps are formed to the contour of the sphere and cross at 45 degrees off the fore and aft centerline of the float. Each strap is a fabricated HTS "I" section 2 3/4 inches deep by 3 1/2 inches wide. The two straps are welded at the center, making the strap assembly one unit. The flange adjacent to the sphere and the web are 1/4-inch plate and the outside flange is 1/2-inch plate. The inside flange and web of each strap are cut away in the vicinity of the sphere clamping ring. A 1/2-inch by 3-inch rubber pad separates the inside flange and the sphere. A HY-80 clevis is welded to the outside flange on the four ends.

6-11. HULL ATTACHMENT. The four strap brackets supporting the sphere are located diagonally 45 degrees off centerline around the sphere recess in the float. Each bracket consists of a 2 1/2-inch HTS block and two 1/2-inch HTS plates. The two plates have full penetration welds to the block and to a 1-inch HTS plate hull insert. The blocks are a minimum distance of 4 inches from the hull and have a 1 1/2-inch spherical radius socket machined on the hull side. The internal structure of the float is reinforced at the support bracket locations. A special 1 1/2-inch diameter, HY-80 eye bolt is attached to each clevis on the sphere straps by means of 1 1/2-inch pin and fastened to the support bracket blocks with a special 1 1/2-inch, 6 NC-3 spherical nut and jam nut. The nuts are provided with special spanner wrench holes to facilitate tightening the nuts and securing the sphere.

6-12. Additional padeyes are welded to the outboard side of each hull bracket for use in lifting the sphere during installation. These pads are constructed of 1-inch plate with a 1 1/16-inch diameter drilled hole.

6-13. BUMPERS. In the sphere recess, at the location of the two longitudinal bulkheads, there are six rubber bumpers, 26 inches long, 2 inches wide and 3 inches deep. Two of the bumpers are located at the forward and aft ends of the recess, and one bumper is located on each side at top centerline. The bumpers are sandwiched between two 1/4-inch plates and secured with five CRES bolts. The bumpers are mounted radially with respect to the sphere and are compressed about 3/8 inch when the sphere is strapped in place.

6-14. SPHERE ORIENTATION. The main viewport of the sphere is tilted 25 degrees below horizontal with the hatch positioned 20 degrees aft of vertical. The horizontal centerline of the sphere in this position is located on the base line of the float.

6-15. ACCESS TRUNK SEAL. A plate skirt with a 2-inch flange is welded to the underside of the sphere recess flat at 4 feet 9 3/4 inches ABL. A rubber gasket is sandwiched between this flange and a similar flange, which is welded to a portable skirt plate. The portable skirt plate contacts a rubber gasket which is bonded to the sphere paint. The flanges and gasket are secured with thirty-three CRES bolts and self locking nuts. When assembly is complete, the sandwich gasket is compressed to 17/8 inches maximum and the skirt is imbedded in the sphere gasket 1/8 inch minimum.

6-16. FLOAT CONSTRUCTION.

6-17. Longitudinal strength for the hull is provided by two bulkheads located 2 feet 6 inches off the float centerline, port and starboard, running from the bow to the transverse bulkhead at frame 32. A centerline bulkhead divides the hull from frame 32 to the stern. Bulkheads are constructed from 10-gage HTS plate (0.135 inch thick) with vertical and horizontal "T" and flat plate stiffeners. The float is longitudinally framed from the bow to frame 27. The conical hull section aft of frame 27 is framed transversely with 13 circular "T" frames and struts intersecting the frames and longitudinal bulkheads.

6-18. SUPERSTRUCTURE.

6-19. GENERAL. The superstructure consists of a portable false deck and sides that cover the top of the float from 3 feet 10 inches aft of the forward perpendicular (FP) to about 51 feet aft of the FP. The deck and sides are faired both fore and aft. The structure serves as a walking area over the topside mounted equipment and as a fairing to maintain the hydrodynamic characteristics of the vehicle.

6-20. The height of the deck is 1 foot 9 1/2 inches above top centerline of the hull with a maximum walking breadth of 9 1/2 feet (4 feet 9 inches off centerline port and starboard). The sides run from the deck tangent (4 feet 9 inches port and starboard) and over a 6-inch radius to the side tangent and extend down to 3 inches above the hull. Hinged panels are provided port and starboard in the after sections to provide access to wireways and outboard equipment.

6-21. WALKING AREA. The walking area aft of frame 7 consists of hinged aluminum open type gratings; the area forward of frame 7 is fabricated from flanged aluminum plates and perforated. The main transverse framing is spaced a maximum of 50 inches apart using fabricated aluminum T's as deck beams, supported by aluminum pipe stanchions which are bolted to the hull.

6-22. SIDES. The sides are made of five sections (two port, two starboard and a stern section). Each section is made up of aluminum plating and angles used for both transverse framing and longitudinal stiffening. The inboard edge at the deck tangent is bounded by an aluminum channel. The hinged panels are secured by bolting.

6-23. INSTALLATION AND PRESERVATION. The complete superstructure is portable, including the transverse deck beams, deck gratings, longitudinals, intercostals, stanchions and sides. The entire deck surface is painted with a non-skid paint and the sides are painted on the exterior only. The underside is left unpainted to aid in the control of galvanic corrosion.

6-24. FAIRWATER.

6-25. GENERAL. The fairwater is a streamlined protective enclosure for the sphere access trunk and the primary replenishment-servicing equipments. It is fabricated from aluminum to withstand a 500 lb/ft² wave slap and provides protection for personnel entering or leaving the sphere.

6-26. The top of the fairwater is 21 feet 3 inches above the base line, and the forward edge is located on frame 9 (16 feet aft of the FP) and extends aft 9 feet. A work deck area has been provided at 4 foot 6 inches below the top of the fairwater.

6-27. FAIRWATER EQUIPMENT. The fairwater provides for the protection and mounting of: the surface blowdown system for the fore and aft main ballast tanks, the electrical compensating tanks, the access trunk and drain line traps, the emergency compensating mercury traps, and the main gasoline filling and pumping connection. In addition, the fairwater also provides for the mounting of the electrical disconnect and patch panel, sonar transducers, navigational lights, antennae, and mast.

6-28. REACH RODS AND OPERATING GEAR.

6-29. GENERAL. Three of the Trieste II systems require special remote valve operating gear. These systems are the electrical compensation tank (ECT) flood and drain valve, the forward and aft main ballast tank (MBT) vent valves, and the access trunk flood valve.

6-30. ELECTRICAL COMPENSATION TANK FLOOD AND DRAIN VALVE. The ECT flood and drain valve is located on the port side in the bottom of the electrical compensation tank. This valve is operated by a reach rod which runs from the valve up through the tank top to a handle wheel. The handle wheel is located approximately above the valve at frame 13C on the port side between the hull and the superstructure walking deck.

6-31. MAIN BALLAST TANK VENT VALVES. The MBT vent valves are located on the tops of the main ballast tanks. The forward main ballast tank vent valve is operated by a 12-inch handle located on the top of the forward main ballast tank. If the valve handle is vertical the valve is open, if the handle is slanted toward the superstructure, the valve is closed. The valve can be pinned in the open or closed position as desired. The aft main ballast tank valve is operated by a T-shaped handle which protrudes above the superstructure on the port side of frame 25. If the "T" handle is up, then the valve is open, if the "T" handle is down, the valve is closed. The valve handle can be pinned in the open or closed position as desired.

6-32. ACCESS TRUNK FLOOD VALVE. The access trunk flood valve is located inside, at the bottom of the access trunk. This valve is operated by a flexible cable which is attached to the valve stem and runs up the inside of the trunk and terminates on the starboard side near the top of the trunk. The upper end of the flexible cable has a special end nut which can be turned by a portable "T" wrench. The end nut can only be reached when the access trunk hatch is open.

6-33. FOUNDATIONS.

6-34. GENERAL. The foundations are divided into the following three groups and are listed in order of their importance.

1. Ballast Dropping Gear - provides for ballast control and emergency ballast dump.

2. Equipment Dropping Gear - provides for operational mission of the vessel and for safely jettisoning equipment.

3. Miscellaneous Foundations - provides for the attachment of various mechanical and electrical items.

6-35. CONSTRUCTION. Three items of equipment located in the critical areas on the lower surface of the vehicle are provided with special breakaway bolts to prevent entrapment of the vehicle to the ocean floor by cables or ropes. They are the two pan and tilt mechanisms, located 2 feet 9 inches port and starboard of the centerline at about frame 5, along with the lower CTFM sonar located 4-1/6 inches forward of frame 6 and 2 feet 9 inches to starboard.

6-36. The manipulator arm, trail ball winch, the forward port and starboard and aft shot tubs and the external bow device are provided with electromagnetic releases. The remaining equipment located on the lower surface of the vehicle in areas of possible fouling have been provided with suitable aluminum pipe rope guards.

6-37. TRIPPING LEVERS.

6-38. GENERAL. Six equipment items aboard the vehicle are provided with a quick-release, tripping lever mechanism that permits additional buoyancy control of the vehicle in the event of entanglement of other emergency conditions.

The trail ball winch, manipulator arm, forward port and starboard shot tubs, aft shot tub, and the external bow device are secured by tripping levers which can be released from inside the sphere. The tripping levers (Figure 6-1) are actuated by electromagnets which are powered from the internal 12-VDC power system. A locking pin and a turnbuckle are provided to secure the lever and prevent accidental release of the equipment while the vehicle is being towed or when it is docked.

6-39. OPERATION AND CONTROL. Prior to diving, the release magnets on the tripping levers are energized and the holding pins and turnbuckles are removed. Switches on the Ballast Control Panel (BCP) are used to release the individual equipment items under emergency de-ballasting conditions. The selected switch de-energizes the corresponding electromagnet, tripping the lever and releasing the equipment item. A cover is provided on the BCP to prevent accidental de-ballasting of the equipment. If the individual battery source to any one of the tripping lever systems is lost, that system will be jettisoned since the magnet has no holding power without electrical current. If the equipment is not dropped during the dive, the holding pins and turnbuckle are reinstalled when the vehicle surfaces before de-energizing the holding magnets.

6-40. WEAK LINK AND GUILLOTINE CABLE SEPARATION. When an equipment item must be jettisoned, the control or power cable supplying the unit must also be severed to ensure total separation. A "weak link" in the cable or a Guillotine (cable cutter) is used for this purpose.

6-41. Weak Link Application. The "weak link" section of a cable is constructed by stripping the cable down to the inner conductor and insulation. A thin layer of polyurethane is then potted in this area to provide the necessary protection against the undersea environment. When the equipment with the "weak link" cable is released, positive separation takes place at the prepared point in the cable. The manipulator arm, the forward port and starboard shot tubs and the aft shot tub are provided with "weak-link" cable sections.

6-42. Guillotine Assembly. The Guillotine assembly serves as the means of severing the electrical power and control cables connecting the trail ball winch and cable tension sensor equipment to the float. The guillotining operation takes place automatically when the trail rope release mechanism is tripped. When the centerline device and the external bow device are deployed during a mission, they are also equipped with the Guillotine assembly. The assembly consists of a base plate supporting the prepositioned and clamped electrical conductors to be severed, and a sliding knife which is actuated by the falling motion of the jettisoned foundation. The cable section to be severed is prepared in the same manner as the "weak link", by stripping the insulation down to the individual conductors and potting the section. Cutting the cable through the ribbon of polyurethane ensures positive separation of the equipment from the vehicle.

6-43. BATTERY BOXES.

6-44. GENERAL. There are two battery boxes, a 24-volt and a 120-volt box, located on the battery flat in the battery compartment about (50.17 feet aft

of the FP) and clamped to the battery flats. The 24-volt battery box is compartmented to sixteen sections, and measures about 45 inches square and stands 35 inches high. The 120-volt battery box is compartmented into 81 sections, and measures about 51 inches square and stands 23 inches high.

6-45. CONSTRUCTION. Both boxes have open flanged tops and are fitted with pyramided covers that are provided with access and compensation piping plates. The covers are bolted to the boxes, and sealed with a 1/4-inch rubber gasket. The boxes are filled with a non-conductive oil and piped to the compensation tanks located on the forward bulkhead of the battery compartment.

6-46. HANDLING. The battery boxes are lowered into position through the battery compartment access with the respective lifting gear assemblies.

6-47. STABILIZERS.

6-48. GENERAL. Four stabilizers (two upper and two lower) are located on the aft conical section of the float between frames 33 and 39 and have a hydrofoil cross-sectional shape. The upper stabilizers are approximately 10 feet 9 inches long and the tips are raised to 38 degrees above the horizontal and provide a mounting plate for the wing propulsion motors at 14 feet 3 1/2 inches ABL.

6-49. DESIGN. The four aft stabilizers are designed to be free flooding with the upper stabilizers also providing a wire way for the propulsion motors. The lower stabilizers are located radially 90 degrees from the upper stabilizers and are about 12 feet 6 inches long. These are connected at the lower tips with a horizontal stabilizer at 11 1/2 inches below the base line of the vehicle. This horizontal member provides additional stiffening to the lower stabilizers when the vehicle comes in contact with the ocean floor and/or during docking evolutions. The bottom of the lower stabilizers are fitted with inflatable "Air Ride" shock mitigation mounts and air piping, and form the landing gear supports for docking the vehicle. Lead ballast is stowed in the lower stabilizers above the shock mitigation mounts to provide the maximum effectiveness in lowering the vehicle's center of gravity. The stabilizers are constructed of HTS using conventional spars, ribs and outer skin to form the basic structure. The upper stabilizers are designed to withstand 1000 lb/ft² wave slap. The lower stabilizers are designed to withstand normal landing loads. Spars are tied to reinforced hull frames in the stern section.

6-50. FORWARD LANDING SKEGS. The lower extremities of the forward landing skegs are also fitted with a shock mitigation system similar to that of the lower stabilizers. Recesses are provided in the forward skegs for the installation and removal of the forward shot tubs.

6-51. PROPULSION.

6-52. GENERAL. Each propulsion unit is designed as a free-flooding housing that provides a hydrodynamic fairing for the gear motor. The location of the four motor units are: One at the main axis on centerline, forming the aft perpendicular; one on each upper stabilizer tip with shaft centerlines at 15 feet 4 1/2 inches above base line; and one as a bow thruster, mounted top side on the forward superstructure.

6-53. FUNCTIONS. The centerline motor provides main propulsion thrust for 2-knot cruising when the vehicle is in the clean configuration (less when outfitted with bow frame and appendages). The wing (upper stabilizer) motors provide for a top speed of approximately 3 knots, when used in conjunction with the centerline motor and with the vehicle in the clean configuration. The wing motors are also used for steering and for hovering in conjunction with the bow thruster. The various motor combinations and operator control provide adequate maneuverability for search and recovery operations.

6-54. NOZZLES AND FAIRING. The propulsion units are equipped with fiberglass Kort nozzles and are supported by three pylons.

6-55. The faired lines of each motor housing and pylons are designed to reduce water turbulence. The basic structure of each motor housing contains a propeller shaft bearing support and provisions for lifting and handling. The shaft bearings are of the water lubricated type and the bow thruster bearing is a sleeve assembly. The center line unit housing forms the stern of the vehicle with the forward motor end recessed into the float.

6-56. PROTECTIVE EQUIPMENT FOR TOWING. A mechanical brake is provided for the centerline and wing motor shafts to prevent the motors from turning under tow. The brake consists of a cam mechanism mounted on the inside of the motor fairings. The cams clamp down on a disc attached to propeller shaft and are operated by turning a shaft which extends outside of motor fairing. This shaft may be locked to the fairing boss in the brake ON or OFF position, by inserting a cotter pin in hole provided. A special non-sparking box wrench is provided for operating the brake.

6-57. BOW WINCH.

6-58. GENERAL. The bow winch is located at the centerline, just below the superstructure. The lifting capacity of the bow winch is 5000 pounds. A 1/2-inch, 6 x 37 fiber core (galvanized improved plow steel) wire rope 60 feet long is used on the winch and has a breaking strength of 20,400 pounds. The winch is capable of lifting a heavier load than its 5000-pound lifting capacity by holding the desired item with the hook and using the lifting (buoyancy) force of the vehicle. The bitter end of the cable is not attached to the drum and therefore can be jettisoned if the hook or the wire rope become entangled.

6-59. POWER AND BRAKING. This bow winch is powered by a 5 hp DC motor which transmits its brake horsepower to the winch shaft and a harmonic drive. This reduces the motor's 1750 rpm to 7.24 rpm and provides a maximum output torque of 75,000 inch-pounds. The braking of the motor is transmitted by using a roller chain flexible coupling. The maximum torque outputs for each of the brakes when submerged in compensating fluid, are 12 foot-pounds for the brake with no solenoid, and 18 foot-pounds for the brake with a solenoid. These brakes must be adjusted to hold 10 ± 2 foot-pounds for the brake with no solenoid, and 30 ± 5 foot-pounds for both brakes together. When the winch is hoisting, the solenoid equipped brake is disengaged, but the brake without

the solenoid remains engaged to keep the wire rope taut. When the winch is in the lowering mode both brakes are engaged. The bow hoisting winch assembly is compensated independently from the other compensating systems by a 1300 cubic inch bellows assembly which is filled with 1-centistoke silicone fluid in accordance with VV-D-1078.

6-60. HOLDING MECHANISM. There is also a bow device holding mechanism which is located on the end of the bow frame centerline. Pre-tensioning in this case is accomplished by the electrical control of the winch itself through a device called the remote control unit. This device pulls on the "holding" cable originating from the bow device hoist winch. This bow device hoist winch can hold the special equipment that the vehicle's crew should require to accomplish its mission. The bow device release has also been provided with an additional spring release to insure against no load condition and residual magnetism. The bow winch and its associated gear is housed so that only the cable and hook could become entangled when diving, and this can be released since the cable is not secured to the drum at the bitter end.

6-61. TRAIL BALL WINCH.

6-62. GENERAL. The trail ball winch assembly weighs 400 pounds in air excluding the trail ball and is located at frame 26 through 28 centerline, at the baseline of the vehicle. The winch is capable of hoisting and lowering the lead trail ball to facilitate the vehicles approach to the ocean floor. A footage counter on the winch can be used to establish the height that the vehicle maintains above the ocean bottom while the vehicle is moving or hovering during periods of observation. By raising or lowering the ball to the ocean floor, the trail ball winch provides additional vertical control.

6-63. CONTROL PANEL. The Trail Rope Winch Control Panel is located on the Ballast Control Panel. The operator can control the trail ball system from this control panel. The panel consists of a ball rope footage counter which indicates the length of wire rope extended from the winch. The panel also has a vertical force meter which measures the vertical force on the wire rope in two ranges which are changed by the 1X/2X toggle switch 0-500, and 0 to 1000 \pm 6% pounds.

6-64. The IN/OFF/OUT toggle switch controls the motion of the winch for reeling in, stopping, and reeling out. The NORM/LIMIT toggle switch overrides the limit switch that prevents the trail ball from being reeled in or released entirely. This switch is spring loaded in the NORM position and must be held in the LIMIT position to override the limit switch. The SCALE potentiometer is used to calibrate the tension measuring system when the lead ball is supported by the wire rope. The BAL potentiometer is used to calibrate the tension measuring system when the lead ball is on the ocean floor and there is no tension on the wire rope.

6-65. The trail ball winch control assembly is located on the portside, aft of the sail. This assembly is pressure tested and contains relays and controls for the DC motor.

6-66. WINCH CAPABILITIES. The trail ball winch is capable of hoisting and lowering a 260 pound lead ball. The winch also has the capability of lifting a 825 pound lead ball, but use of this trail ball is not currently planned. The trail ball is attached to the winch drum with 65 feet of 3/16-inch, 7 x 7 stainless steel wire rope which has a breaking strength of 3700 pounds. This hydrographic winch wire rope is capable of rough service and has an estimated useful service of three to four months in a sea water environment.

6-67. POWER AND DRIVE TRAIN. The winch is powered by a 1.5 hp, 12.5 amp (normally running), 110-VDC motor that can reel in the wire rope at 18 ft/min (no load) and at 17 ft/min with the 295 pound trail ball (weight in air).

6-68. A motor slip clutch is located between the drive motor and the worm-to-worm gear assembly of the cable drum reduction gear box. The motor slip clutch is designed to slip each time the trail ball is fully seated in the ball rest during the stowing operation. This clutch prevents the operator from inadvertently breaking a cable or stalling and damaging the motor when the trail ball is seated or when the cable force exerted by the gear train exceeds approximately 1500 pounds.

6-69. FOOTAGE COUNTER. The trail ball winch is equipped with a cable footage counter (with manual reset) which can add and subtract from 0 to 100 feet. The winch is also provided with upper and lower limit switches. The lower limit switch prevents the wire rope from accidentally being dropped off the drum, and is set at 50 ± 2 feet. If the operator desires more cable payout the limit switch must be overridden. The upper limit switch allows all but 2 feet of cable to be reeled in on the drum. The operator must override the limit switch to reel the last 2 feet of the cable and house the trail ball.

6-70. JETTISONING PROVISIONS. The trail ball and cable can be jettisoned should they become entangled, since the bitter end of the cable is not attached to the winch drum. The winch assembly itself can also be jettisoned by tripping the trail ball release mechanism. This automatically actuates the guillotine assembly severing the electrical power and control cables connecting the winch and cable tension sensor equipment to the vehicle.

6-71. COMPENSATION. The trail ball winch assembly is compensated independently from other compensating systems by a bellows assembly which is filled with hydraulic oil.

6-72. MANIPULATOR ARM.

6-73. GENERAL. The manipulator arm foundation is located at frame 2 centerline at the baseline. The manipulator arm consists of a shoulder, upper arm, forearm, wrist and jaw, and enables the operator to pick up 500 pound objects vertically and 200 pound objects horizontally. By operating the appropriate controls within the sphere the operator can perform underwater tasks such as: small object recovery (one dimension of the object must be less than 8 inches); attachment of lines from the surface to objects below; cable cutting; and planting buoys or marker beacons (transponders). The manipulator arm has a reach of 75 inches.

6-74. SYSTEM COMPONENTS. The manipulator system consists of an electrical control unit, DC starter, hydraulic pump driven by an electric motor, hydraulic reservoir, three pressure compensators, an articulated (movable) platform or a fixed platform, and the manipulator arm assembly (Figure 6-2).

6-75. POWER AND CONTROL. The electrical control unit, DC starter and electrical motor form an electrical subsystem that powers the hydraulic pump and controls the arm and the swing platform operation. The hydraulic pump, reservoir, and pressure compensators form the subsystem that powers the manipulator arm and swing platform actuators and in addition, protects the manipulator arm components from imploding.

6-76. The control unit consists of a rack-mounted chassis and a portable remote control box that is attached by two retractable cords. The remote box can be stored on the chassis in the sphere on the left side of the device control panel in the middle of Bay 3. The chassis controls electrical and hydraulic on-off operation and the portable remote control box actuates arm and platform movement.

6-77. The DC starter box has two main contactors, one accelerating contactor for reduced voltage starting, an overload relay and various resistors enclosed in a stainless steel box mounted on the starboard side of the main deck filled with 1-centistoke silicone fluid in accordance with VV-D-1078. This unit provides the starting power for the motor pump unit.

6-78. The motor pump box contains the electric motor and the hydraulic pump. The stainless steel box is located on the starboard side of the main deck aft of the DC starter box and is filled with silicone fluid in accord with VV-D-1078, 1-centistoke for compensation. A 3 hp, 1750 rpm, 110-VDC electric motor drives the hydraulic pump. The hydraulic pump is a positive displacement axial piston pump capable of maintaining 2 gpm at 1750 rpm with an output pressure of 3000 psig. The hydraulic reservoir is a sump providing 6 gallons of hydraulic fluid (MIL-H-5606) and contains filters and a relief valve.

6-79. ARTICULATED AND FIXED PLATFORMS. Mission requirements dictate the use of either the articulated (pantograph) or fixed platforms. The selected platform is installed during the mission preparation stage, normally in the deck of the support ship.

6-80. Articulated Platform. The articulated (movable) platform is hydraulically operated and is mounted to the vehicle underside. It is capable of extending the mounting plate 6 feet 10 inches below the vehicle. The articulated platform therefore increases the range of the fully extended manipulator arm to 13 feet 1 inch below the vehicle.

6-81. Fixed Platform. The fixed platform gives the arm a full length reach of 7 foot 3 inches below the vehicle.

6-82. SYSTEM COMPENSATION. The manipulator system is provided with a contained compensating system, which consists of three stainless steel piston compensators. These compensators allow the water pressure to push the spring-loaded piston down on the oil, forcing the oil into the boxes to maintain a constant pressure differential between the system fluid and external sea pressure. Two 750 cubic-inch piston compensators are connected to the motor pump box, and filled with 1-centistoke silicone fluid in accordance with VV-D-1078. A second system compensates the hydraulic reservoir with one 750 cubic inch piston compensator. The fluid used to compensate this system is hydraulic fluid MIL-H-5606. Chapter 2 provides a more complete description on the compensating piping.

6-83. FIRE FIGHTING EQUIPMENT.

6-84. One five-pound carbon dioxide fire extinguisher is located in the bottom portion of Bay 1 and is provided to extinguish any small fires that should arise in the sphere.

WARNING

Prior to using the carbon dioxide fire extinguisher, the emergency breathing masks must be worn as the carbon dioxide concentration will not support life.

6-85. During fueling and degassing operations a 1 1/2-inch IPS fire hose is sent out from the after port side of the support ship to hose down any AVGAS spills and could also be used to control any fires that occur on the vehicle while it is being towed.

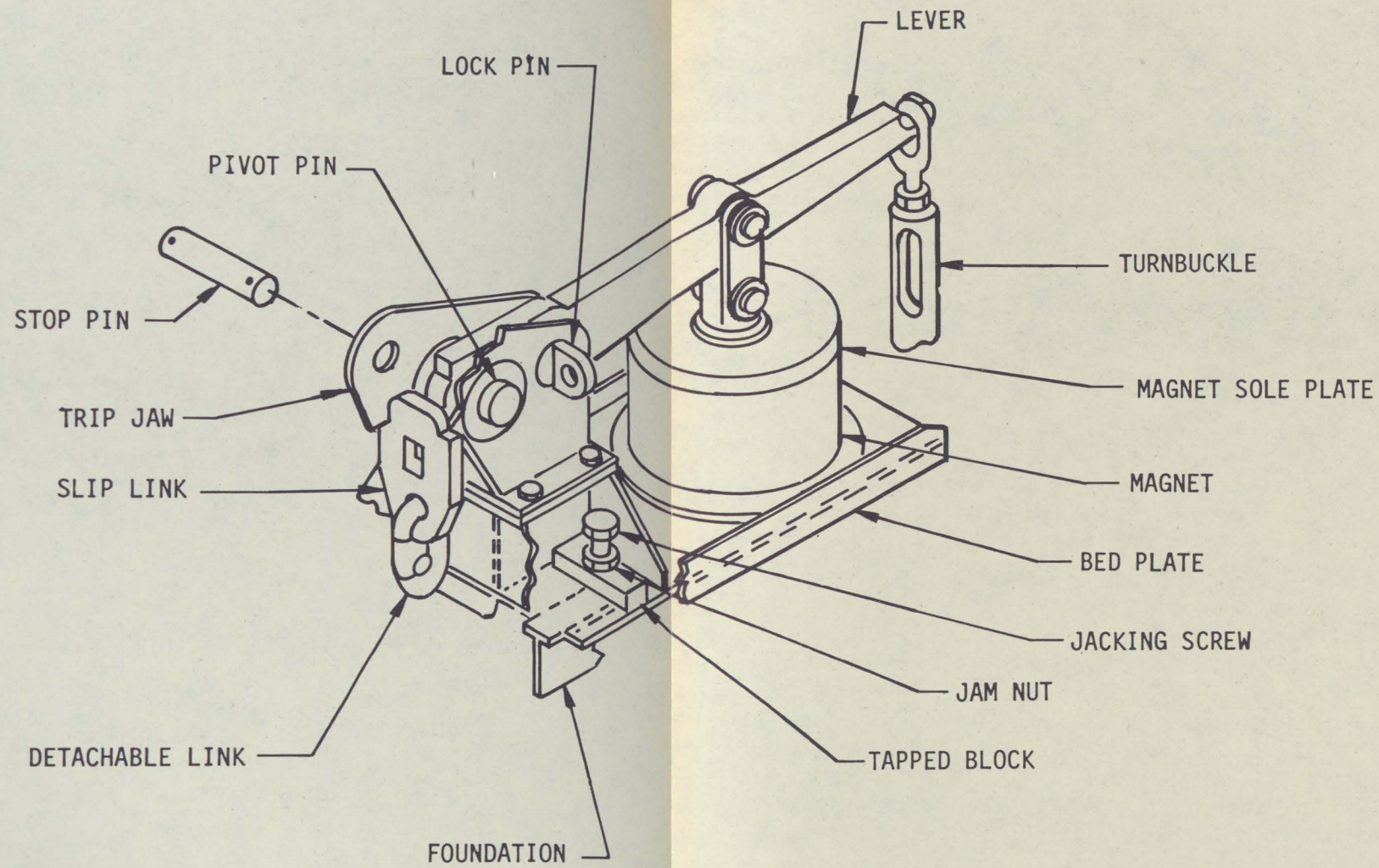

FIGURE 6-1. ELECTROMAGNETIC TRIPPING LEVER

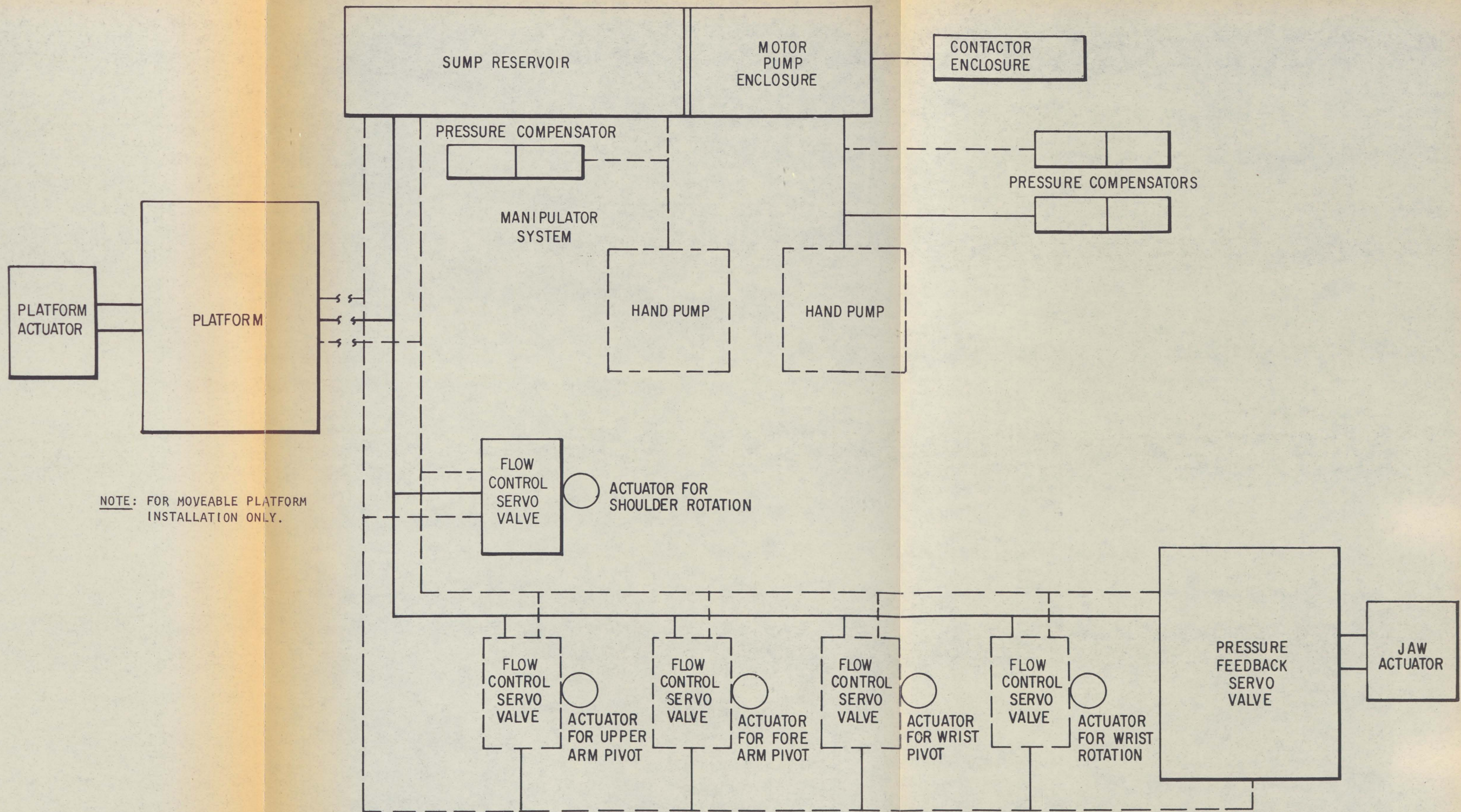

FIGURE 6-2. MANIPULATOR HYDRAULIC BLOCK SYSTEM

SUPPORT SHIP

CHAPTER 7

SUPPORT SHIP INTERFACE

Number		Page
7-1.	Introduction	7-1
7-3.	USS Point Loma Ship Characteristics	7-1
7-5.	General Support Ship Capabilities	7-1
7-7.	Services and Interfaces	7-2

CHAPTER 7

SUPPORT SHIP INTERFACE

7-1. INTRODUCTION.

7-2. This chapter describes the services and interfaces necessary to support Trieste II (DSV-1) operations during a mission. The service, stowage and docking systems afforded by the surface ship comprise the support ship interface with the vehicle. The sophisticated electronic sensor and photographic equipment on the vehicle demand highly-specialized technical skills and a detailed knowledge of the on-board systems. Since the success of an operational dive depends heavily on an integrated team effort, the maintenance and repair activities are conducted primarily by the Trieste II crew, with support ship personnel assisting as necessary. The support ship diving officer and his detachment provide closely-coordinated services for pre- and post-dive operations.

7-3. USS POINT LOMA SHIP CHARACTERISTICS.

7-4. The support ship for the Trieste II is the USS Point Loma, AGDS-2 (Cargo Ship Dock). The AGDS-2 displaces approximately 10,000 tons, is 465 feet in overall length, with a beam of 74 feet and draught of 40 feet (MLD) at side to main deck (midships). The cruising speed of the vessel is approximately 15 knots with a 10,000 mile cruising radius at normal 6000 shaft horsepower. The Point Loma has been extensively modified as a transport and tender facility to accommodate Trieste II (DSV-1) operations. The ship permanent complement comprises 180 enlisted men (15 chiefs) and 10 officers (two warrant officers), plus several civilian technical representatives assigned according to the operational task. Berthing and messing accommodations for all mission personnel is provided by the support ship. Figure 7-1 provides a plan view of the support ship showing the major services and interfaces described in this chapter.

7-5. GENERAL SUPPORT SHIP CAPABILITIES.

7-6. The USS Point Loma has been modified to accommodate the overall Trieste II requirements for tender and transport operations. The principal capabilities of the support ship include the following:

1. Trieste II transport from base to the dive area.
2. Docking and undocking facilities for the vehicle.
3. Stowage and handling of two Hawser, one Bertram and two Boston Whaler boats, located on the 03 level of the ship.

4. Stateroom and wardroom accommodations for Trieste II officers, enlisted personnel and civilian technical representatives.
5. Conference room, recreation room, offices, galley, messing, and barber shop on the 02, 01 levels and the main deck.
6. Deck-mounted vans for electrical and electronics storage and test, and battery charging on the main deck.
7. Stowage and handling of AVGAS, steel shot and compensating oil.
8. Nitrogen stowage and inerting capabilities.
9. Machinery, Hull and electrical workshops and photolab.
10. Plotting and tracking station, and signal shelter on the 04 level.
11. Radio room and electronics center on the 03 level, including the AN/SRN-9A Satellite Navigation System.
12. Diving equipment locker room and diving services.
13. Crane and fork-lift services.
14. Hardware and interface hoses and cables for servicing the vehicle while aboard and/or in tow.

7-7. SERVICES AND INTERFACES.

7-8. GENERAL. The USS Point Loma has a docking well and beach area aft of Frame 130 (Figure 7-2) where the vehicle is tethered and blocked for transit, and where docking and undocking can be accomplished on-station. During transit and dive period, the support ship well is pumped dry.

7-9. Services performed while the vehicle is docked consist primarily of preventative maintenance, repair, inspection, battery charging and monitoring, pressurizing air flasks and other pre- and post-dive mechanics as required.

7-10. Primary interfaces during transit consist of preventive maintenance preparation for on-station dive, inspection and operational test of vehicle equipment, reviewing procedures and instructions, and mission briefing of Trieste and support ship personnel.

7-11. On-station, the navigation field or search area must be established and surveyed, and coordinates located. This orientation is normally accomplished prior to undocking the vehicle through use of the AN/SRN-9 Satellite Navigation System aboard the support ship. Other on-station interface items include handling lines, fire hoses, towing line and capstan, high- and low-pressure air hoses, grounding cable, communication cable, AVGAS hose, nitrogen hose, shot slurry hose, diver equipment, small boats, the Bertram tracking boat and the Hawser boat with two lines.

7-12. TOWING SYSTEM. Prior to flooding the dock well, a tow line is attached to the aft end of the vehicle and to the hawser boat which has been unloaded from the support ship. A main tow line is attached to the towing pad on the bow of the vehicle and to the capstan on the main deck of the support ship (near Frame 52 on the centerline). When the vehicle is water borne, the hawser boat takes up tension on the tow line over the stern gate of the dock well. The hawser boat maintains this tension as the gate is lowered. Handling lines on both sides of the vehicle are manned to control movement as the vehicle is slowly pulled from the dock. The hawser boat is the prime mover, pulling the vehicle directly aft as the capstan is paying out at the same rate. During the undocking, a Trieste II officer is stationed on the sail of the vehicle to observe and direct the operation via a hand-held FM transceiver.

7-13. When the vehicle is approximately 500 feet astern of the support ship, the stern gate is closed and the dock well pumped out as quickly as possible for ship safety and sea keeping considerations. When a steady tow has been established, the vehicle is hauled to within 150 feet of the support ship in preparation for AVGAS filling, shot loading and further pre-dive operations. During this period, whale boats with divers are in close proximity to the vehicle for assistance as required.

7-14. Main Tow Line. A 27 foot, 1 3/4-inch rope serves as the main towing line for the vehicle. The line is connected to the main towing pad at 9 foot ABL on the bow of the vehicle by a 1 1/2-inch diameter shackle through a thimble braided to the towing line. The leading end of the line is provided with a main towing "pear" link through a thimble, braided to it for the pelican hook connection from the towing line of the support ship.

7-15. Protective Equipment for Towing. A mechanical brake is provided for the centerline and stabilizer (wing) motor shafts on the vehicle to prevent turning of the motors under tow. The brake consists of a cam mechanism mounted on the inside of the motor fairings. The cams clamp down on a disc attached to the propeller shaft and are operated by turning a shaft which extends outside of the motor fairings. This shaft may be locked to the fairing boss in the brake ON or OFF position by inserting a cotter pin. A special non-sparking wrench is provided for operating the brake.

7-16. UNDOCKING, DOCKING AND TIE DOWN.

7-17. Undocking. Prior to undocking, a check-off list is used and rechecked to ensure that all maintenance and/or repair items have been completed and that all cameras, lights and electrical connections are secure. A complete washdown is then performed to check for any electrical leaks and grounds. All lenses are cleaned and checked. The restraining grips are then removed from the vehicle and the shock mitigation devices are inflated so that the transit blocks can be removed.

7-18. The vehicle is inerted with nitrogen to provide a tightness check of the float and to reduce the concentration of oxygen in preparation for AVGAS filling. Handling lines are rigged and a crewman or officer is

stationed in the sail of the vehicle. A whale boat and hawser boat are then lowered into the water. The hawser boat has the tow line connected to the aft end of the vehicle over the stern gate at this point in the undocking operations. The capstan and vehicle tow line are attached to the bow of the vehicle.

7-19. The flooding of the dock well is started and continues until the sphere is submerged. At this point, the flooding is stopped and a brief inspection of the sphere is conducted. Flooding is continued until the vehicle is water borne, at which point final checking procedures are commenced, including inspection for leaks and grounds and bad electrical connections from within the sphere using radio communications for verification.

7-20. The fixed tie lines are slacked and flooding continues until the vehicle is buoyant. The handling lines (Figure 7-3) are manned and cinched one turn for vehicle stability. The stern gate of the support ship is then lowered and the hawser boat hauls away. Handling lines are directed by the undocking officer and the lines (five on each side) move sequentially aft and as they reach the end of the catwalk they are removed.

7-21. The vehicle is hauled approximately 500 feet aft of the support ship (Figure 7-4) and immediately, the stern gate is closed and pumping of the dock well is commenced. This is accomplished before any other procedures are undertaken to ensure the safety and sea-keeping ability of the support ship. At this point, the undocking phase is essentially complete and the vehicle is hauled to within 150 feet of the ship in preparation for AVGAS filling and shot loading.

7-22. Docking. The docking procedure begins after completion of the final operational dive. The support ship tow line is attached to the main vehicle tow line and the hawser boat line is attached to the stern of the vehicle. After the AVGAS is pumped back aboard the support ship, the vehicle is inerted, then washed down with fire hose, the shot removed (dropped), the diver attended procedures completed, and the shock mitigation airbags inflated, the support ship dock well is again flooded, the stern gate opened and the vehicle hauled slowly into the well. Handling lines are attached and manned sequentially as the vehicle advances into the dock and reaches the tie-down position (Figure 7-3).

7-23. Tie-Down. Once the vehicle is in position in the dock well of the support ship and cinched up with handling lines, the well pump down operation is initiated. The vehicle is washed down again as the dock well is pumped out. When the pumping down operation is completed, the transit blocks are positioned under the landing gear and the shock mitigation air bags are deflated to allow the vehicle to rest solid on the landing gear. The fixed tie lines are attached to the vehicle in preparation for transit and the handling lines are removed and stowed. The final residual AVGAS is then drained from the vehicle and any spillage immediately washed down. Figures 7-5 and 7-6 show the in-transit lashing arrangements. Figure 7-7 shows the vehicle in the dock well during transit.

7-24. AVGAS SYSTEM.

7-25. General. The support ship has the tank and pumping capabilities for storing and handling the AVGAS used in the vehicle's buoyancy system. Approximately 100,000 gallons of the aviation gasoline are contained aboard the support ship. The AVGAS is pumped to the vehicle while under tow conditions and prior to the dive. Following the dive, and while the vehicle is under tow, the AVGAS is pumped back into the support ship storage tanks.

7-26. AVGAS Connections. The filling and pumping outlet from the support ship consists of a 4-inch flanged hose connection located near the stern and port side of the dock well at the base line. This provides the quick connection point for the AVGAS hose, which is strung out on floats and connected to the vehicle AVGAS system through a special elbow.

7-27. AVGAS Filling. The pumping system on the support ship consists of two 168 gpm @ 65 psi positive displacement pumps. There is no pressure buildup in the vehicle AVGAS tanks since the vent valves at the top of the tanks are open during the fill process. When the vehicle tanks are nearly full, and to prevent excessive gas overflow, topping is accomplished by using a 2-inch AVGAS hose. During the topping off procedure, the pressure is monitored with a pressure gage located on the special elbow. For safety purposes, the sound-powered phone system is used for communications between the vehicle and the support ship during AVGAS filling and pumping.

7-28. AVGAS Pumping. After a dive is completed and prior to docking, the vehicle must be degassed by reversing the filling procedure. AVGAS is pumped from the vehicle back to the storage tanks in the support ship. The vehicle tanks cannot be completely emptied by this method and residual AVGAS (up to 5000 gallons) remains in the tanks until the vehicle is brought into the dock well. The residual AVGAS is then drained using the two male, quick-disconnect cam-locking type hose connections provided on the port side of the dock well.

7-29. Nitrogen Inerting. Nitrogen inerting (back filling) is required during AVGAS pumping to provide a safety factor by replacing any oxygen in the tanks with the inert gas. The nitrogen also provides a head pressure to assist the pumps. After docking and draining the residual AVGAS, the vehicle tanks are purged with low pressure air until an explosive meter will read Zero for three consecutive readings over a specified time period. If it is difficult to achieve this Zero reading, fresh water wash down of AVGAS tanks may be necessary.

7-30. NITROGEN SYSTEM. The inerting nitrogen is stored aboard the support ship in 3000 psi flasks whose total capacity is 84,500 standard cubic feet. The nitrogen is reduced from 3000 psi to 95 psi at the inerting station, which is located on the main deck, aft, portside on the support ship. A flexible hose equipped with quick-disconnect fittings on both ends connects this inerting station with the portable and permanent nitrogen piping aboard the vehicle (Figure 7-8).

7-31. HIGH-PRESSURE AIR SYSTEM. The high-pressure (HP) air system on the support ship can produce 40 cubic feet per hour @ 3000 psi. High-pressure flasks are also available on the ship to store 24 cubic feet @ 3000 psig. There is also a high-pressure booster compressor on the support ship capable of increasing the 3000 psig air to 5000 psi.

7-32. The vehicle and the Bertram tracking boat require HP air at 3000 psig. The support ship HP air is used to charge the high-pressure air flasks on the vehicle. These HP air flasks are used to blow the access trunk when the vehicle surfaces. The Bertram tracking boat stores HP air in HP flasks. This air is reduced and is used to blow the forward and aft ballast tanks on the vehicle, and in an emergency to blow the access trunks.

7-33. The HP air service outlet which is used when the vehicle is in tow is located on the main deck, aft, starboard side of the support ship (Figure 7-9).

7-34. LOW-PRESSURE AIR SYSTEM.

7-35. General. The low-pressure (LP) air system on the support ship can produce air on 125 psig to supply the vehicle and crew with the necessary air to power pneumatic tools for maintenance and repair, operate the red devil blower which ventilates (purges) the AVGAS tanks, inflate and service the shock mitigation system in the landing gear to vent and drain the access trunk, electric compensation tank and the forward and aft main ballast tanks.

7-36. Low-Pressure Outlets. There are three low-pressure air outlets on the support ship. One fitting is located on the main deck, aft, starboard side of the support ship and is used if low-pressure air is required when towing the vehicle. The other two LP air outlets are located on the port and on the starboard dock well at the second deck. These outlets are used when LP air is required to service the vehicle in the dock well.

7-37. Low-Pressure Dehumidified Air. The support ship is also equipped with a low-pressure air compressor that produces 29 ft³/min @ 175 psi. The output from this LP compressor is processed through an air drier (25 ft³/min @ 100 psi) to provide LP air to ventilate the sphere during towing operation and/or when the vehicle is in the dock well. Low-pressure dehumidified air is also used to ventilate the sphere during testing or maintenance. The LP dehumidified air outlet is located next to the LP air outlet on the main deck, aft, starboard side of the support ship.

7-38. FIRE MAIN SYSTEM. Seawater which is used to wash down the overflow of AVGAS is provided through a fire main outlet which is located on the main deck, aft port side of the support ship. Seawater is also used to carry the ballast shot into the vehicle in a slurry form. The outlet used to transport the shot is located on the main deck, aft starboard side of the support ship.

7-39. BATTERY CHARGING FACILITIES.

7-40. General. The battery charging facilities for the vehicle consist of four floating (320-foot) charging cables, receptacle boxes mounted on the support ship, charging jack assemblies (Units 917 and 918) mounted on the vehicle sail, jumper cables and the battery charging van (Fly-Away Van). Figure 7-10 shows the general arrangement and cabling of the battery charging facility.

7-41. The 24-VDC and 120-VDC batteries on the vehicle can be charged in the dock well of the support ship or under tow conditions. Charging cables run from the vehicle charging jacks in the sail to either the van or to the support ship receptacle boxes. When the charging cables run to the receptacle boxes (No. 2 and No. 3) on the fantail of the support ship, jumper cables must be run from the van to the receptacle box (No. 1). The battery charging van contains the charging breaker control panel, high-rate detector and alarm panel and the Udylete Battery Chargers. When the vehicle is in the dock well, the charging cables may be connected to the van.

7-42. Charging Cables. The charging cables and the monitor cable are the direct link between the vehicle and the battery charging van on the support ship. The cable complement consists of two 24-VDC charging cables, one 120-VDC charging cable and a monitor cable. The cables are of a floating, waterproof, multiple conductor type. The individual cables and their functions are described below:

1. Charging Cable No. 100 - Plus 24-VDC charging power. This cable consists of two #4/0 AWG and three #12 AWG conductors. The #4/0 conductors carry the +24VDC charging power and the #12 conductors carry the battery circuit breaker remote control circuit. The vehicle end of charging cable No. 100 is connected to corresponding connectors in the 24VDC charging jack Assembly (Unit 917) in the sail. The support ship end of the cable is connected to either the 24VDC receptacle box or directly to the van.

2. Charging Cable No. 200 - 24-VDC return charging power. This cable consists of two #4/0 AWG and three #6 AWG conductors. The #4/0 conductors carry the -24VDC return charging power and the #6 conductors carry the control power for the remote control circuits of the battery charging breaker. The vehicle end of cable #200 is connected to corresponding connectors in the 24VDC charging jack assembly (Unit 917) in the sail. The support ship end of the cable is connected to either the 24VDC receptable box or directly to the van.

3. Charging Cable No. 300 - 120-VDC charging power. This cable consists of two #2/0 AWG and three #6 AWG conductors. The #2/0 conductors carry the 120-VDC charging power and return. The #6 conductors carry the 120-VDC charging breaker control power. The vehicle end of cable No. 300 connects to the corresponding connectors in the 120-VDC charging jack assembly (Unit 918) in the sail. The support ship end of the cable is connected to the 120-VDC receptable box or directly to the van.

4. Cable No. 400 - Battery monitor cable. This cable consists of seven #12 AWG and fourteen #16 AWG conductors. The cable carries the 120-VDC battery circuit breaker control voltage, the 24-VDC battery and the 120-VDC battery sensing voltage, scan switch motor control and the battery cell monitoring voltages. The vehicle end of cable No. 400 has seven connectors that mate with corresponding connectors in the 120-VDC charging jack assembly (Unit 918) on the sail. The support ship end of the cable has four connectors that connect to the 120-VDC receptacle boxes or directly to the van.

7-43. Receptacle Boxes. The receptacle boxes mounted on the support ship provide quick connect and disconnect capabilities for the vehicle battery charging and monitor cables. The boxes also provide the means for connecting jumper cables from the van to midship receptacle box. The boxes are waterproof terminations of the battery charging and monitoring cables from the van to the vehicle.

7-44. There are three receptacle boxes: one 120-VDC box, No. 3, one 24-VDC box, No. 2, and one midship box, No. 1, which combines the 24-VDC and 120-VDC functions. The midship box has the same connector receptacles as those found in the vehicle charging jack assemblies on the sail (Units 917, 918). The fantail boxes No. 2 and No. 3 have the same connector receptacles as those found on the van. This arrangement provides the flexibility to use the van jumper cables or the vehicle floating type cables to charge and monitor the vehicle batteries if problems should develop with the cables or the vehicle floating type cables to charge and monitor the vehicle batteries if problems should develop with the cables or while the vehicle is in the dock well or being towed.

7-45. Jumper Cables. Jumper cables eliminate the problems associated with hardwiring the van to the receptacles boxes. The jumpers allow the van to be moved and also provide the capability of charging the vehicle batteries directly from the van with an extra set of charging cables if necessary.

7-46. Battery Charging Van. The battery charging van (Electrical Fly-Away Van-Figure 7-10) contains the battery chargers, high-rate detector and alarm panel, and the battery charging breaker control panel. The entire battery charging process for the vehicle is remotely controlled from this area. Individual van equipment is described below.

1. BATTERY CHARGERS. The battery chargers are 440V, 3 Phase, 60Hz rectifier stacks with regulated voltage outputs, manufactured by Udylite Corporation. These units can be controlled manually or automatically to maintain desired voltage and current levels. These units also supply control voltage for the charging breaker control panel.

2. CHARGING BREAKER CONTROL PANEL. The control panel consists of four ITE type spring-centered control switches mounted in an enclosure of suitable size and used to provide open/close controls for the two battery breakers (24VDC and 120VDC) and for the two charging breakers (24VDC and 120VDC) located in the vehicle. The control voltages for the battery circuit breakers is 24VDC and for the charging breakers the control voltage is 120 VDC. Both control voltages are routed to their respective controlling units via the charging cables and monitor cable.

3. HIGH-RATE DETECTOR AND ALARM PANEL. The high-rate detector receives sensing signals from the motor-operated scanner switch located in the 120VDC battery box of the vehicle. Provisions for voltage indication and cell position indication for individual cells are made available at this unit. The high-rate alarm points are relay controlled through this unit. If a cell exceeds the preset reference voltage, the scan switch will stop at that position and a visual and audible alarm will be activated. It is then necessary to reset the alarm at the high-rate unit in order for the scan switch to continue operation. The alarm panel has the audible alarm for each battery and operable through the relay units of the high-rate detector.

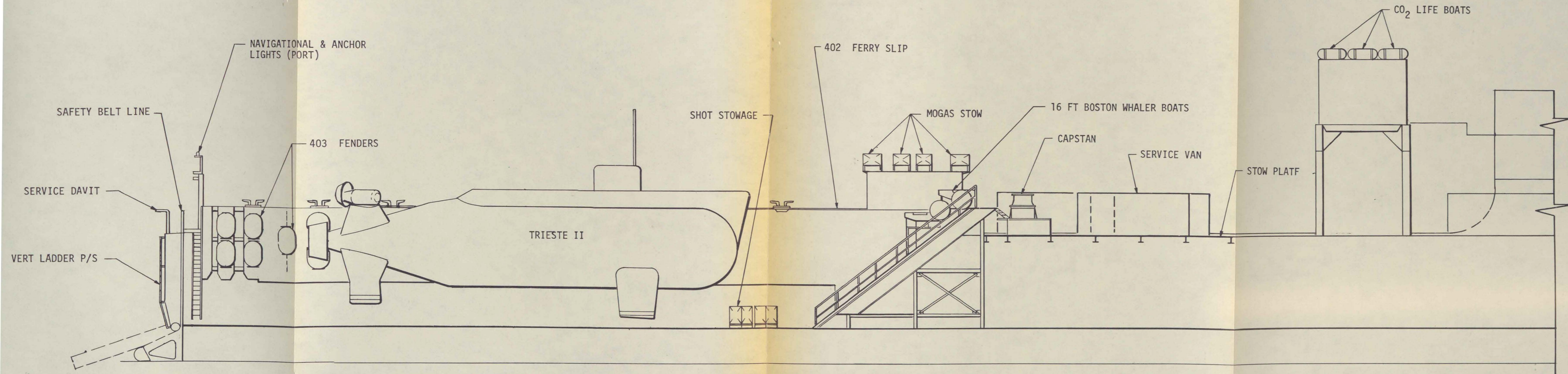

FIGURE 7-2. DOCKING WELL AND BEACH AREA

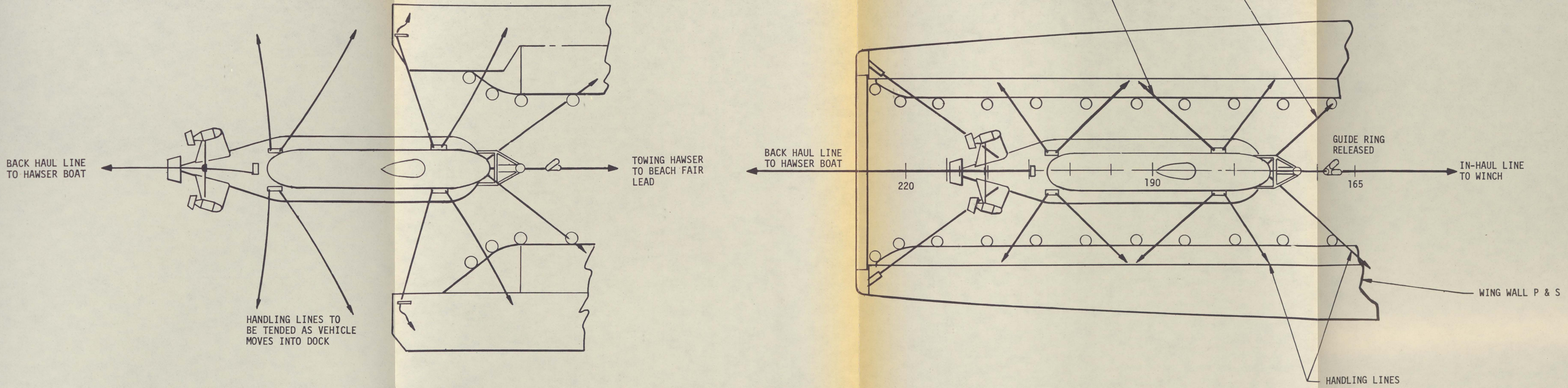

FIGURE 7-3. VEHICLE HANDLING LINES

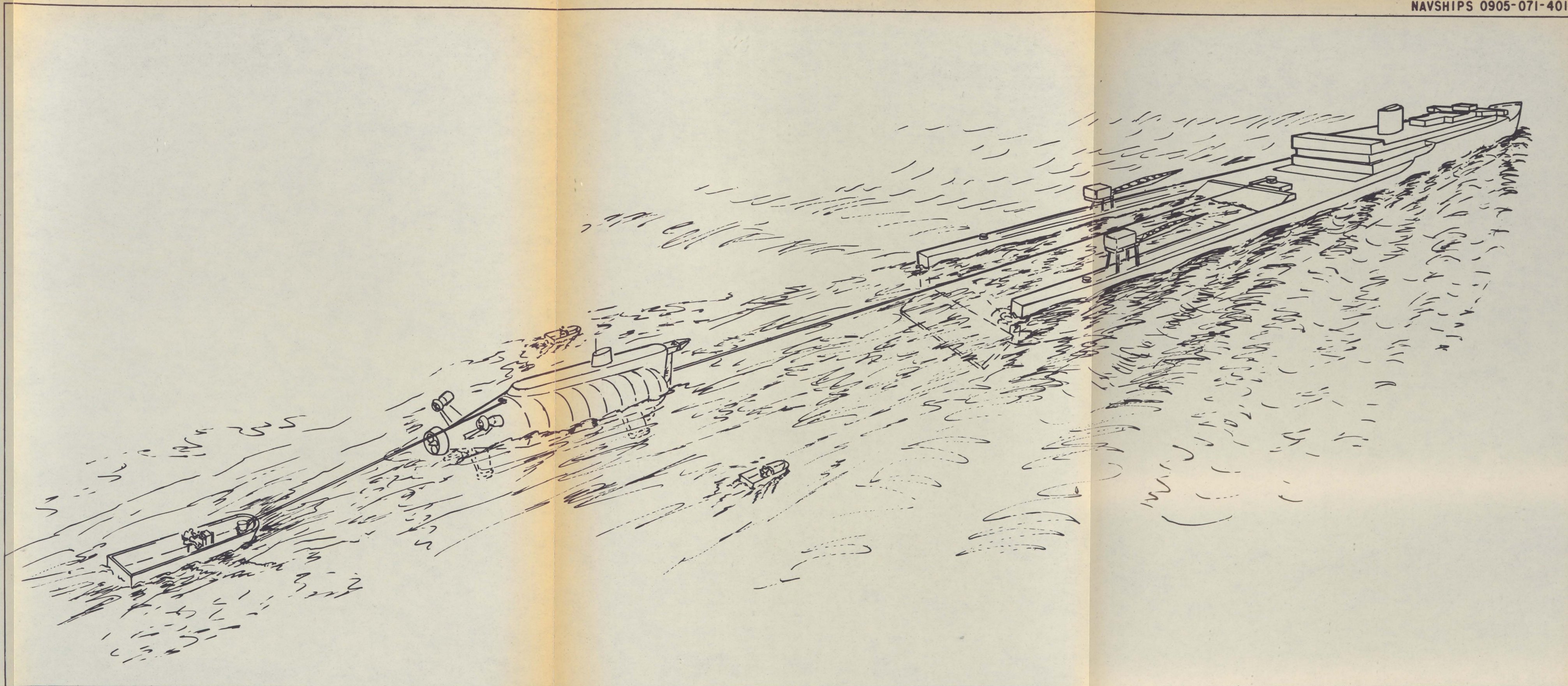

FIGURE 7-4. UNDOCKING ARRANGEMENT

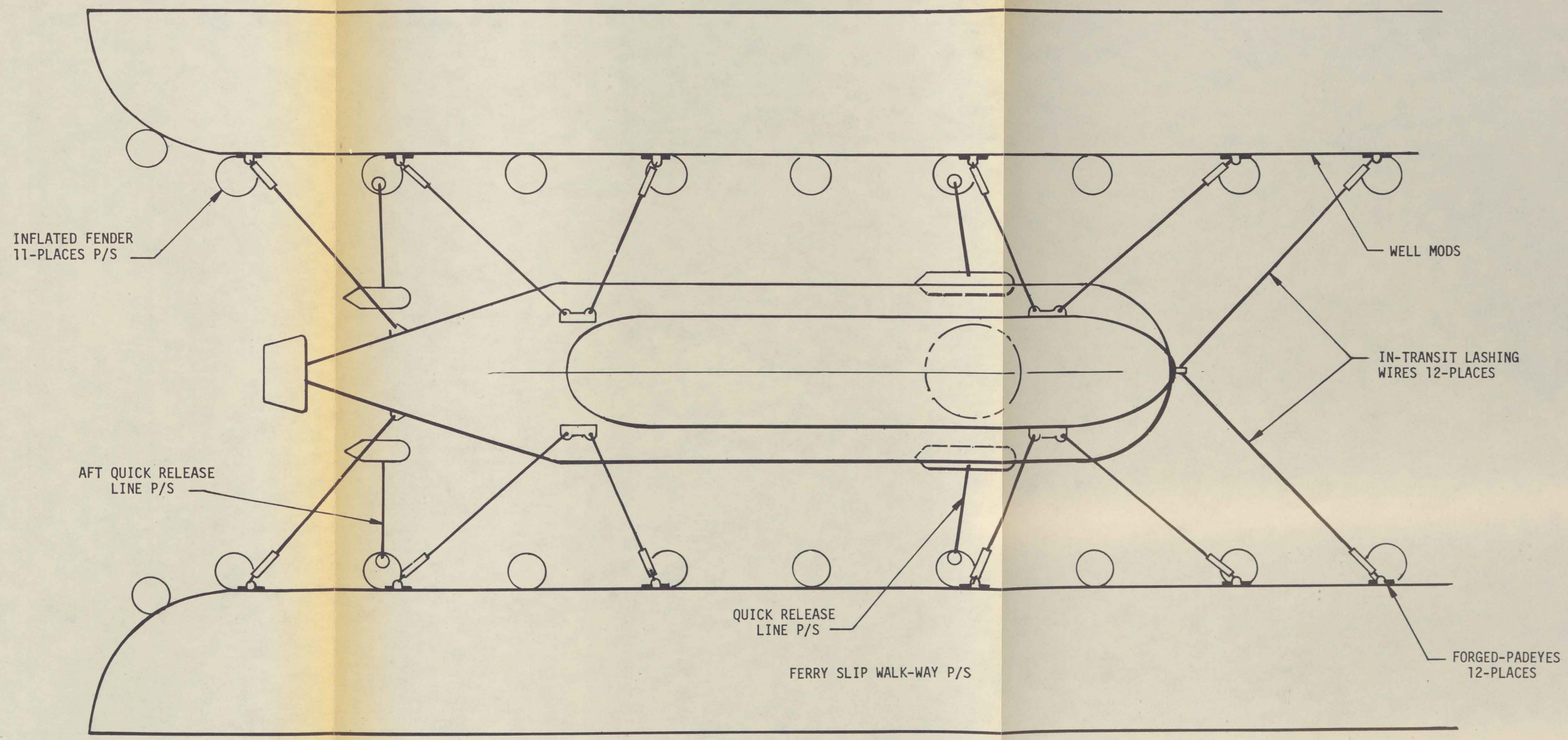
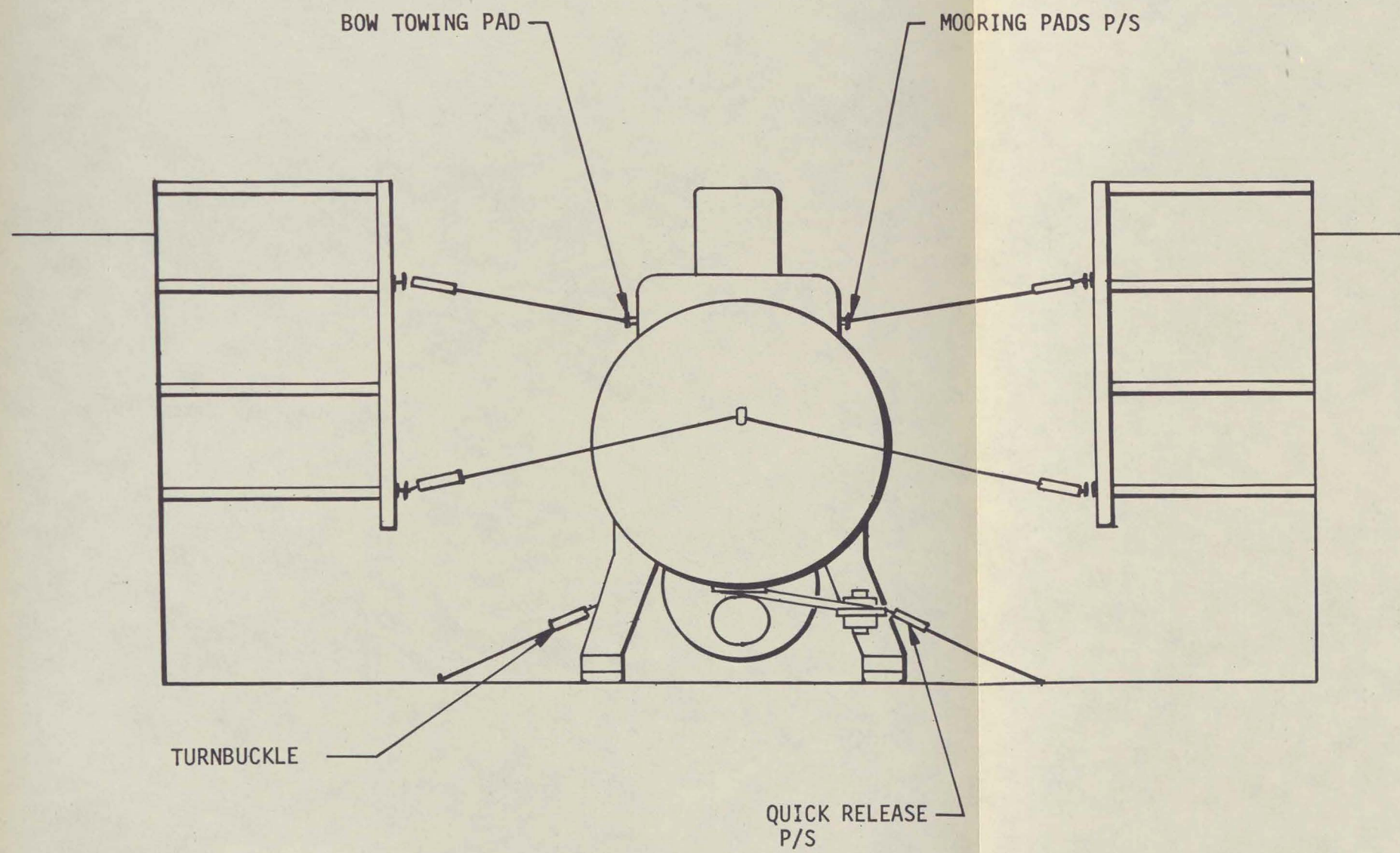

FIGURE 7-5. IN-TRANSIT LASHING ARRANGEMENTS
PLAN VIEW

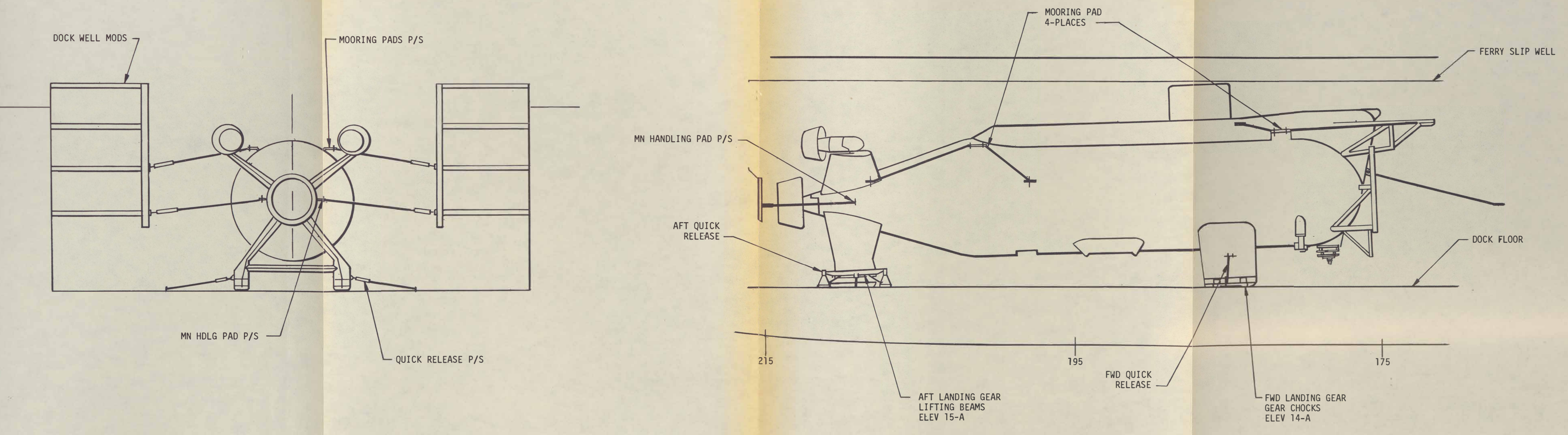

FIGURE 7-6. IN-TRANSIT LASHING ARRANGEMENTS ELEVATION

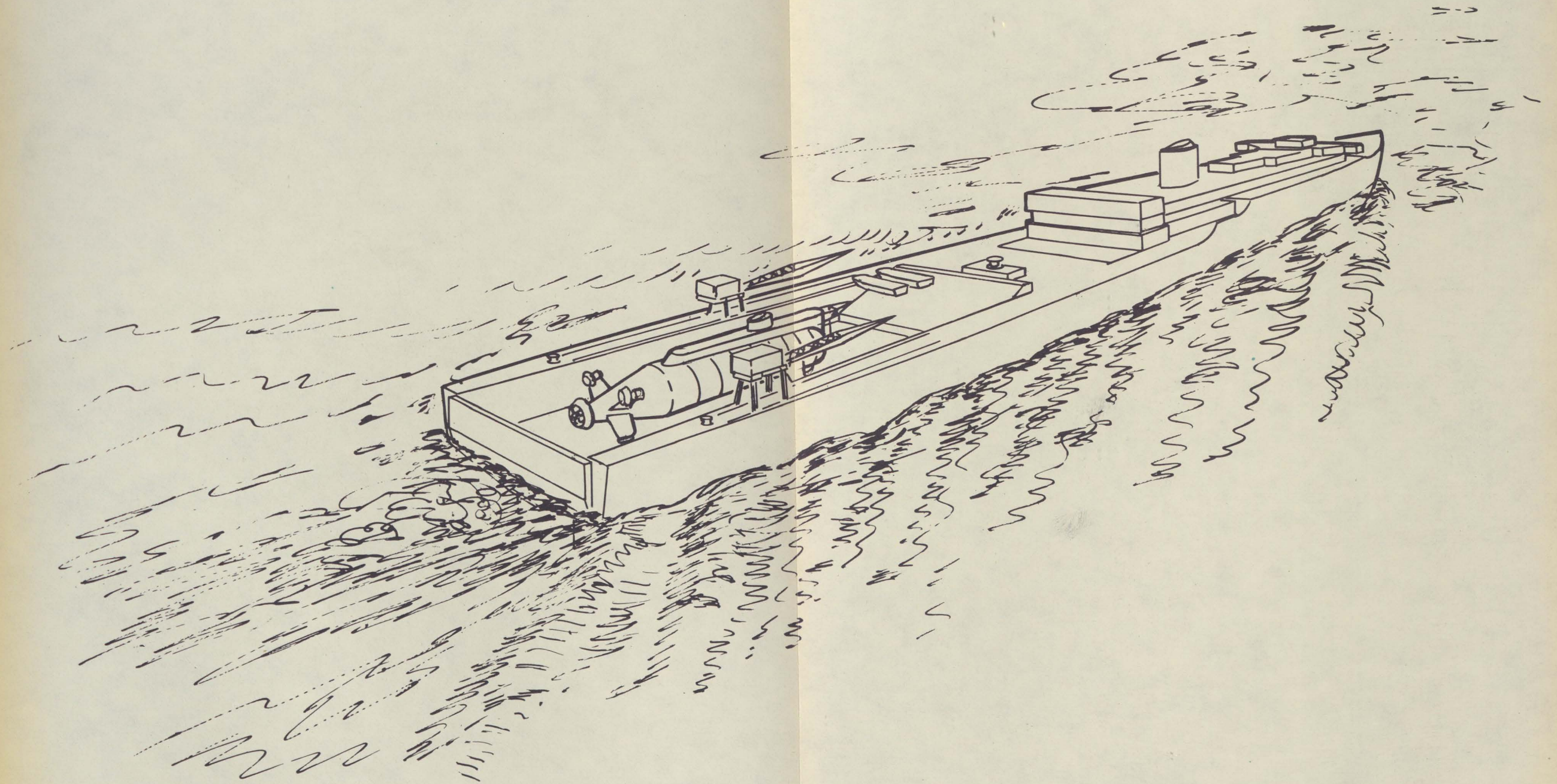

FIGURE 7-7. TRANSIT CONFIGURATION

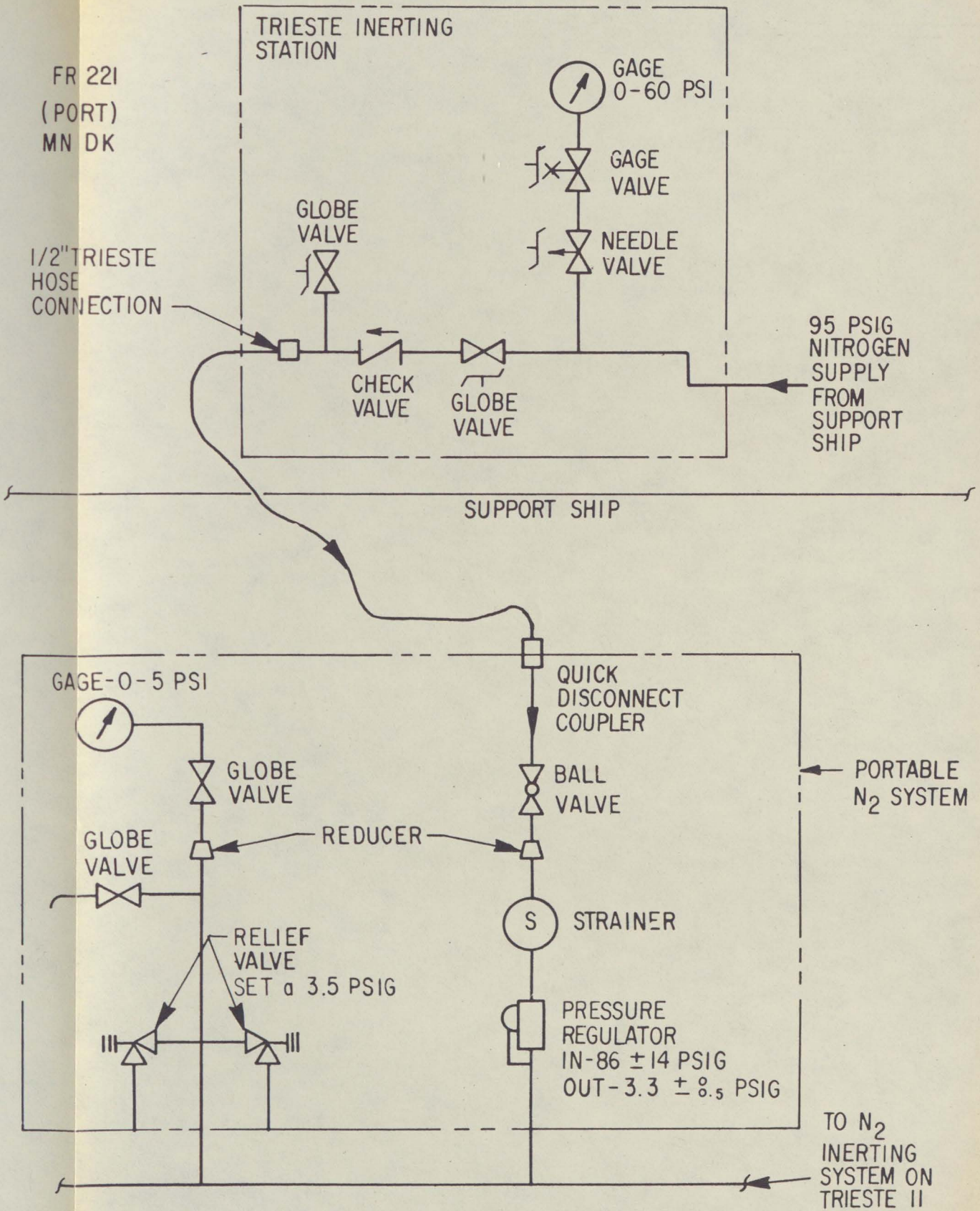

FIGURE 7-8. NITROGEN SYSTEM INTERFACE

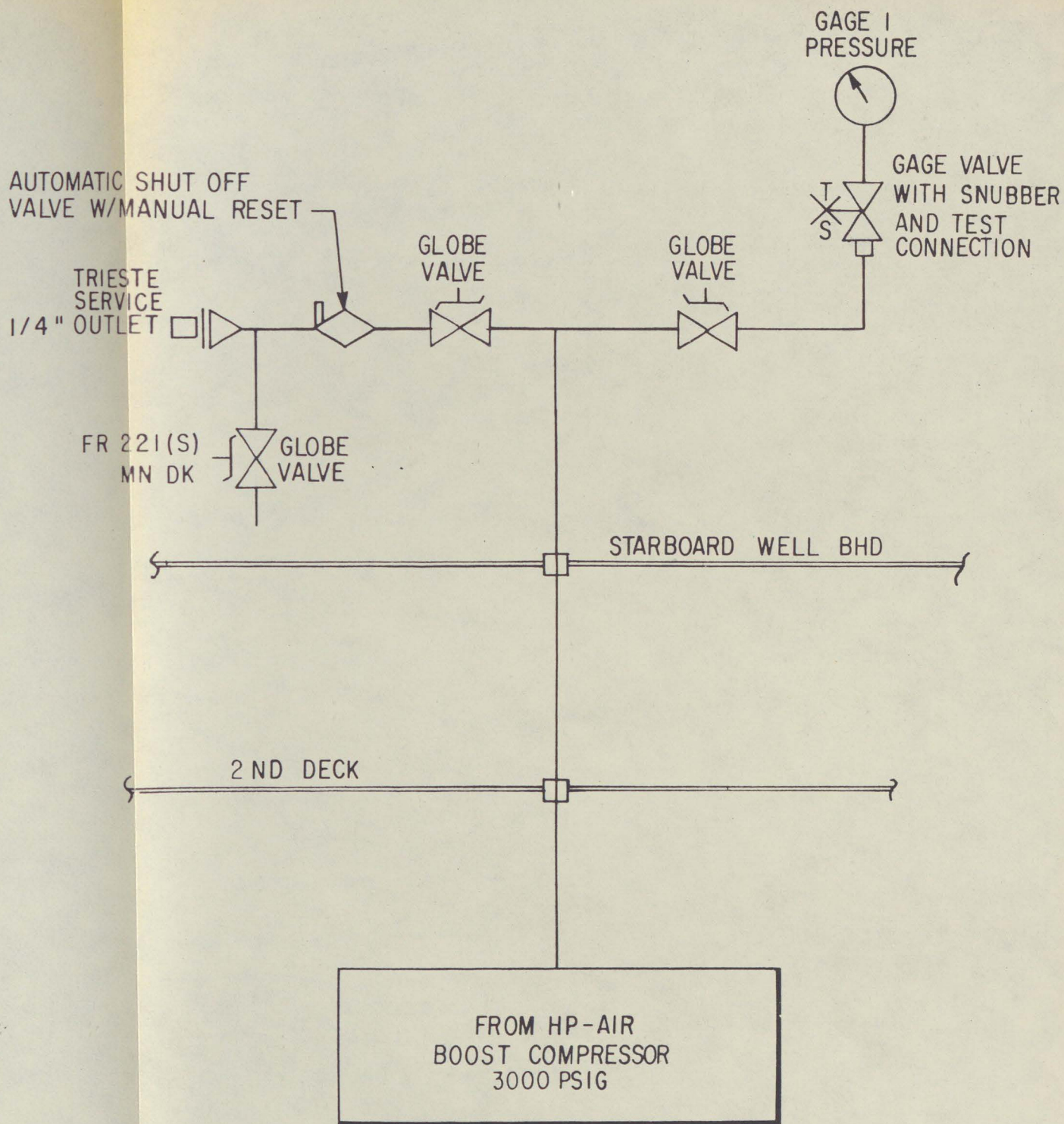

FIGURE 7-9. HIGH-PRESSURE AIR SERVICE OUTLET

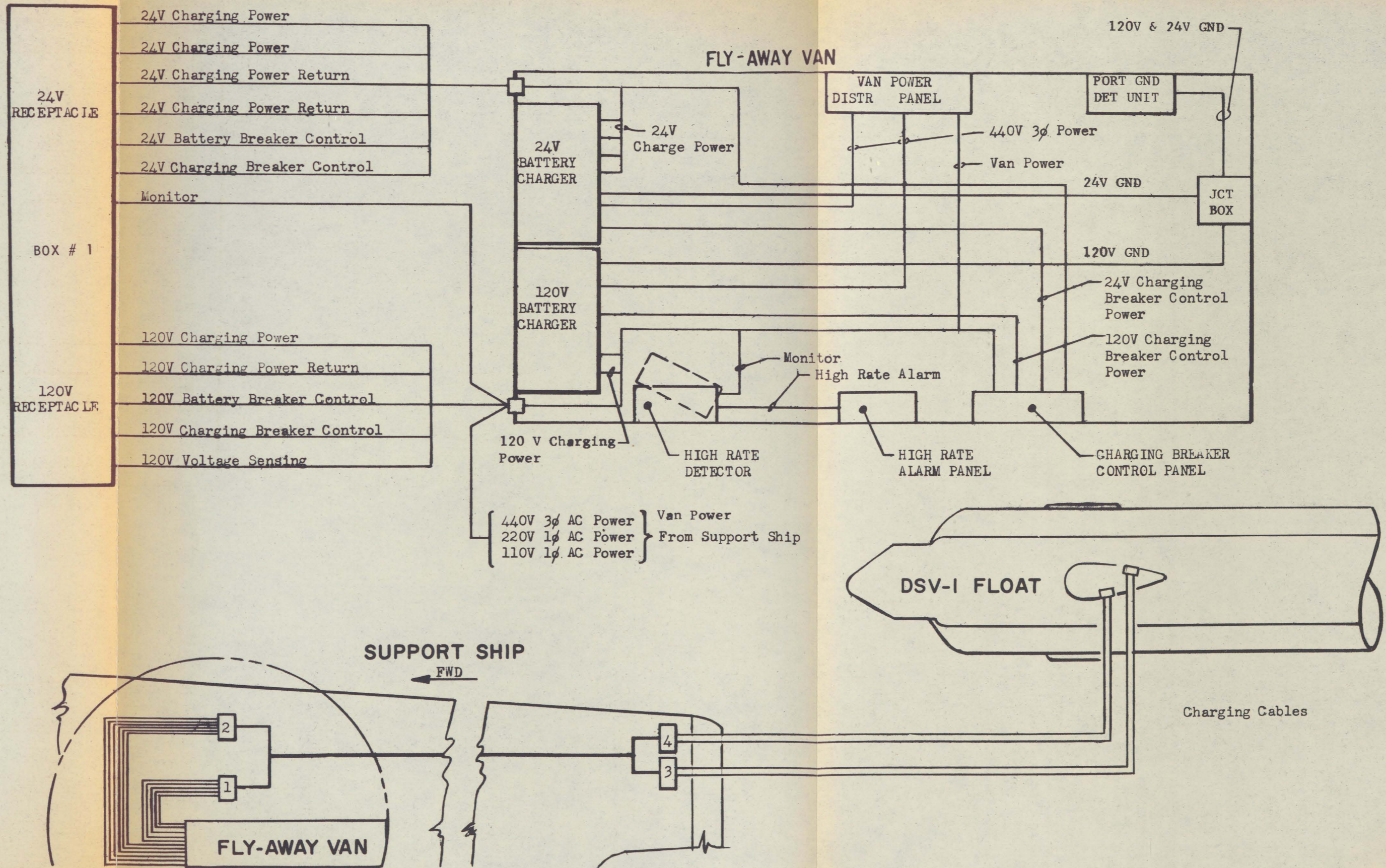

FIGURE 7-10. BATTERY CHARGING FACILITY AND CABLING

GLOSSARY 1
ABBREVIATIONS AND ACRONYMS

A

ABL - Above base line
 AC - Alternating current
 ACC - Access
 ACDM - Atmospheric carbon dioxide monitor
 ADM - Aft draft marks
 AFT - After
 AH/ah - Ampere-hour
 ALIGN - Alignment
 AMP - Amperes
 AOM - Atmospheric oxygen monitor
 AP - Aft perpendicular
 ADA - American Standards Association
 ASSY - Assembly
 ATM - Atmosphere
 AVGAS - Aviation gasoline
 AWG - American Wire Gage

B

BBL - Below base line
 BCP - Ballast control panel
 Bertram - Trade name - boat
 BL - Base line
 BLK - Block
 Boston Whaler - Commercial "Trade Name" for small whaleboat
 BQN-8 - Navigation transponder (Submarine depth sounder)

BTRY - Battery
 BTu/hr - British thermal units per hour
 B&W - Black and white

C

CB - Center buoyance
 CCW - Counter-clockwise
 cfh - Cubic feet per hour
 CG - Center gravity
 CHG - Charge
 CINCPACFLT - Commander-in-Chief, Pacific Fleet
 CL - Centerline
 CMPTR - Computer
 CMU - Computer memory unit
 CNO - Chief of Naval Operations
 CNTOR - Contactor
 CO₂ - Carbon dioxide
 COMM - Communication(s)
 COMP - Compensator
 COMSUBPAC - Commander Submarine Force, Pacific
 CONT - Control
 CPU - Computer processor unit
 CRES - Corrosive resistant steel
 CRT - Cathode ray tube
 CSDG-1 - Commander, Submarine Development Group One

ABBREVIATIONS AND ACRONYMS (Continued)

C		F	
CTFM	- Continuous transmission frequency modulated	F	- Fahrenheit
CTL	- Central	FDM	- Forward draft marks
CuNi	- Copper-nickel	FDN	- Foundation
CW	- Clockwise; continuous wave	FM	- Frequency modulator
		FMO	- Frequency modulated oscillator
D		FP	- Forward perpendicular
D/A	- Digital-to-analog	FR	- Frame
DC	- Direct current	FT	- Feet
DET	- Detector	FT ³	- Cubic feet
DIST	- Distribution	FT/MIN	- Feet per minute
DIVE	- Surface-to-bottom-to-surface excursion	FWD	- Forward
DOT	- Deep ocean transponder		
DSSP	- Deep Submergency Systems Project office	G	
DSV	- Deep submergence vehicle	GEN	- Generator
DVC	- Device	GENL	- General
DWL	- Designers water line	GND	- Ground
		gpm	- Gallons per minute
		GYRO	- Gyrocompass; gyroscope
E		H	
EBS	- Emergency breathing system	HB	- Half breadth
ECT	- Electrical compensation tank	HHX	- Hull heat exchangers
ELEC	- Electrical/electronic	hp	- Horsepower
ELEX	- Electronics/electrical	HP	- High pressure
EMER	- Emergency	HR	- Hour
EMI	- Electromagnetic interference	HTS	- High-tensile steel
EQPT	- Equipment	HYPH	- Hydrophone
EXT	- External	Hz	- Cycles per second

ABBREVIATIONS AND ACRONYMS (Continued)

I

ID - Identification
 IN - Inch
 IN³ - Cubic inch
 IND - Indicator
 INF - Information
 INTL - Internal
 INV - Inverter
 ips - Inches per second
 IT - Interrogator transponder

J

JBL - Lighting junction
 JCT - Junction

K

kHz - 1000 cycles per second
 K-Monel - Corrosion-resistant nickel alloy, type K
 kW - Kilowatt

L

LB - Pound
 lb/ft² - Pounds per square feet
 LBP - Length between perpendiculars
 L/D - Lift-to-drag ratio
 LIM - Limit
 LiOH - Lithium hydroxide
 LOA - Length over all
 LORAN - Long Range Navigation

LP - Low Pressure
 LTG - Lighting

M

MA - Main axis
 MAN - Manual
 MANIP - Manipulator
 MBL - Molded base line
 MBT - Main ballast tank
 MECH - Mechanics; mechanism
 MEM - Memory
 MHz - 1,000,000 cycles per second
 ML - Molded line
 MM/mm - Millimeter
 MOT - Motor/maximum operating Temperature
 MUX - Multiplex
 MV/mV - Millivolt
 MWF - Multiple conductor, water-tight, flexible special purpose cable

N

N₂ - Nitrogen distribution manifold
 NAND - Logical operator corresponding to not and
 NAV - Navigation
 NEL - Naval Electronics Laboratory
 NUC - Naval Underseas Center

ABBREVIATIONS AND ACRONYMS (Continued)

O		S	
O ₂	- Oxygen	SCFH	- Standard cubic feet per hour
ONR	- U.S. Office of Naval Research		
OP-23	- Operational Planning Division-23, within CNO	SCLM	- Standard cubic liters per minute
OTC	- Officer, Tactical Command	SEC	- Second
		SEQ	- Sequence
		SHIPALTS	- Ships alterations
		SIB	- Ship Information Book
		SIG	- Signal
		SLPM	- Standard liter per minute
		SND	- Sound
		SNR	- Sonar
		SSC	- Surface ship controller
		STBD	- Starboard
		SUBMISS/ SUBSUNK	- Procedure title (and) procedure for submarine search and rescue mission
		SW	- Switch/Seawater
		SYNC	- Synchronization
		SYS	- System
P		T	
PJTR	- Projector		
PMS	- Preventive maintenance system		
PNL	- Panel		
POS	- Positive		
PRESS	- Pressure		
PROCU	- Processing Unit		
PRPLN	- Propulsion		
PSI	- Pounds per square inch		
PSIG	- Pounds per square inch gage		
PT	- Point		
P/T	- Pan and Tilt		
PWR	- Power		
R		T	
RCDR	- Recorder	T/E	- Thermoelectric
RCV	- Receive	TEL	- Telephone
REF	- Reference	TIS	- Transponder interrogator sonar
RLSE	- Release	TK	- Tank
RLY	- Relay	TNG	- Training
RPM	- Revolutions per minute	Ton(long)	- 2240 pounds
RPTR	- Repeater	TV	- Television
RTN	- Return		

ABBREVIATIONS AND ACRONYMS (Continued)

U

UQC	- Underwater telephone communication system	XMTR	- Transmitter
UWTR/ U/W-	Underwater	X-Y	- Plotter (variables) designations

V

V	- Volt
VA	- Voltampere
VAC	- Volts, alternating current
VDC	- Volts, direct current
VEH	- Vehicle
VEL	- Velocity
VERT	- Vertical
vhf	- Very high frequency
VTR	- Video tape recorder

W

W	- Watts
Water Column	- Imaginary tube encompassing total area of dive and navigation (surface-to-bottom-to surface excursion). Also, arbitrary columnar parameters of anticipated descent-ascent path (excursion) that are affected by vehicle trim, water currents, etc.
WEC	- Westinghouse Electric Corporation

X

XDCR	- Transducer
XFR	- Transfer
XMT	- Transmit

GLOSSARY 2

REFERENCES

The following list of drawings and publications are provided as a bibliography and source of additional reference material for the reader. Where specific technical data or parameters are required on the systems described in this SIB, the reader should consult the reference documents which are listed generically, and in the general order of the subject's appearance in the text. The Index of Technical Manuals (ITM) for the Trieste II (DSV-1) is also recommended as an additional source of detailed technical material.

FIGURE NO.	TITLE	REFERENCE NO.
2-1	Trieste Diving System	NAVSHIPS 0905-071-4010
2-2	Deck Vent and Drain System	NAVSHIPS 0905-071-4010
2-3	Gas Drain Valve Assembly and Data	NAVSHIPS 0905-071-4010
2-4	Service and Supply Line Arrangement and Details	NAVSHIPS 0905-071-4010
2-5	Special Fittings	NAVSHIPS 0905-071-4010
2-6	HT, HTI and Access Trunk Line and Vent Details	NAVSHIPS 0905-071-4010
2-7	Valve Detail and Mechanical Linkage	NAVSHIPS 0905-071-4010
2-8		NAVSHIPS 0905-071-4010
2-9		NAVSHIPS 0905-071-4010
2-10		NAVSHIPS 0905-071-4010
2-11	Access Trunk HT Valve System	NAVSHIPS 0905-071-4010
2-12	Special Fittings	NAVSHIPS 0905-071-4010
2-13	High Pressure Air Flasks	NAVSHIPS 0905-071-4010
2-14	Salvage Valve Assembly	NAVSHIPS 0905-071-4010
2-15	Electrical System	NAVSHIPS 0905-071-4010
2-16	HT and Access Trunk Line and Vent System	NAVSHIPS 0905-071-4010

CHAPTER I - REFERENCE

REFERENCE	TITLE	NUMBER
1-1	Displacement and Other Curves	845-1705256
1-2	General Arrangement	845-1520714
1-3	Draft Marks	605-2099266
1-4	Lines and Offsets	845-1520713
1-5	Sphere Assembly and Connections and Details	845-1520122E
1-6	Strain Gage Cabling-Connections and Details	112-2665939
1-7	Sphere Strapping	113-1705241
1-8	Operating Manual	
1-9	Sphere Mods	845-1705294
1-10	Bulkheads Transverse and Longitudinal	114-1520701
1-11	Shell plating and Longitudinals	100-1-20702
1-12	Bow Structure	101-1520703
1-13	Stern Plating	115-1705240
1-14	Superstructure	111-1520704
1-15	Fairwater	111-1705242

CHAPTER II - REFERENCE

REFERENCE	TITLE	NUMBER
2-1	Compensation System	DSV1-504-1520707
2-2	Compensation Valve	DSV1-810-2099275
2-3	Special Fittings	DSV1-515-1705293
2-4	Compensation Valve Feeder Tube Assembly and Details	DSV1-515-1705289
2-5	Maneuvering Valve	DSV1-810-2099276
2-6	Gasoline Filling and Pumping System, Piping Arrangement	DSV1-504-1520708
2-7	Gasoline Tank and Vent Drain System, Piping Arrangement	DSV1-504-1520709
2-8	Service and Supply Hose Arrangement and Details	DSV1-513-2665937
2-9	Compensating System Piping Arrangement	DSV1-504-1520707
2-10	AVGAS Inerting System Piping Arrangement and Details	DSV1-533-4536501
2-11	AVGAS Inerting System Portable Equipment and L/M	DSV1-533-4536502
2-12	Nitrogen System Piping Arrangement	AGDS2-553-4422728
2-13	AVGAS Tank Vent and Drain System	DSV1-504-1520709
2-14	Gas Drain Valves Assembly and Details	DSV1-845-1528094
2-15	Service and Supply Hose Arrangement and Details	DSV1-513-2665937
2-16	Special Fittings	DSV1-515-1705293
2-17	MBT, ECT and Access Trunk Blow and Vent System	DSV1-513-1520720
2-18	Valve Reach Rods and Mechanical Linkage	DSV1-516-1705282
2-19		DSV1-513-1520710
2-20		DSV1-508-1520712
2-21	Access Trunk HP Blow System	DSV1-513-1520711
2-22	Special Fittings	DSV1-515-1705293
2-23	High Pressure Air Flasks	DSV1-501-2096072
2-24	Solenoid Valve Housing	DSV1-115-2096082
2-25	Electrical Systems Plan	DSV1-410-1705278
2-26	ECT and Access Trunk Flood and Drain System	DSV1-518-1520712

CHAPTER II - REFERENCE (Cont'd)

REFERENCE	TITLE	NUMBER
2-27	Sphere Recess and Access Trunk	DSV1-115-1520700
2-28	ECT and Access Trunk Flood and Drain System	DSV1-508-1520712
2-29	Equipment Dropping Gear Structure	DSV1-528-2705250
2-30	Special Fittings	DSV1-515-1705293
2-31	AVGAS Inerting System - Piping Arrangement and Detail	DSV1-553-4536502
2-32	AVGAS Inerting System - Portable Equipment and L/M	DSV1-513-4536502
2-33	Service and Supply Hose Arrangement and Detail	DSV1-513-2665937
2-34	N2 System Piping Arrangement	AGDS2-553-4422728
2-35	Electrical Compensator Piping Test	DSV1-504-T019
2-36	Electrical Compensator Piping Diagram	DSV1-504-1705280
2-37	ECT Piping Accessories	DSV1-516-1705277
2-38	Compensating Tube	DSV1-516-2099258
2-39	Compensator Installation Assembly	DSV1-516-2099259
2-40	MBT, ECT and access trunk blow and vent system	DSV1-513-1520710
2-41	Westinghouse Equipment Compensation System	DSV1-516-1705297
2-42	Fluid Compensator, Manipulator System of 14 July 1967 and Drawing No. Q6-8-3 Title R2X 8 inch Bore x 19-3/4 inch stroke	WEC Technical Note No. 154
2-43	5000 inch ³ Bellows Compensator	WEC Dwg. No. 9370326
2-44	700 and 1300 inch ³ Bellows Compensator	WEC Dwg. No. 9370194
2-45	Trail Rope Winch - Installation, Operation, and Maintenance Winch and Cable Tension Sensor System 11650-101. Electro-Kinetics Corporation, Torrance, California.	
2-46	WEC Compensation Piping	DSV1-516-1705297
2-47	Compensator, Depth Hydraulic Pressure	WEC Dwg. No. 579R785
2-48	Landing Gear Shock Mitigation	DSV1-113-2665942
2-49	Service and Supply Hose Arrangement and Detail	DSV-1-513-2665937

CHAPTER III - REFERENCE

REFERENCE	TITLE	NUMBER
3-1	Main Battery Assembly	302-1520717
3-2	Battery Boxes	200-1705287
3-3	Battery Monitoring System Wiring Diagram	302-1520706
3-4	24-Volt Power Distribution System Cabling Diagram	401-2099246
3-5	Wireways in Battery Tank Installation Details	302-2099248
3-6	24-Volt and 120-Volt Battery Circuit Breaker A&D	302-2099243
3-7	24-Volt Distribution Panel Enclosure A&D	302-2099242
3-8	24-Volt Distribution Panel Assembly and Wiring	302-2099241
3-9	120-Volt and 24-Volt Battery Circuit Breaker Enclosure A&D	302-1705262
3-10	24-Volt and 120-Volt Charging Panels Assembly and Wiring	401-2099252
3-11	Penetrators #1 to #11 Pin Connections Wiring Schedule	302-1705270
3-12	24-Volt and 120-Volt Charging Breaker A&D	401-2099251
3-13	T-II High Pressure Penetrator Hydrostatic Test	PIT-T-E22267
3-14	Main Battery Assembly	302-1520717
3-15	Battery Boxes	200-1705287
3-16	Battery Monitoring System	302-1520706
3-17	120-Volt Power Distribution System Cabling	401-2099246
3-18	External Wireways Installation Details and L/M	302-1705266
3-19	120-Volt Distribution Panel Enclosure Assembly and Details	401-2099245
3-20	Interior Wire List	302-4536509
3-21	Interior Cable Harness Diagram	302-4536510
3-22	Exterior Wire List	302-4536511
3-23	Power Distribution Schematic	302-4536550
3-24	Master Power Panel Schematic	302-4536548
3-25	Master Power Panel Assembly	302-4536549

CHAPTER III - REFERENCE (Cont'd)

REFERENCE	TITLE	NUMBER
3-26	Port and Starboard Power Panel Assembly and Details	302-4536552
3-27	Port and Starboard Power Panel Schematic	302-4536553
3-28	Internal AC and DC Power Distribution	302-4536561
3-29	Penetrator Wiring Panel Assembly and Details	206-4536518
3-30	Unit 700A87 Ampere Hour Meter Assembly	3919C46
3-31	Electrical and Electronic System Cabling and Connections	302-1705278
3-32	Interior Wire List	302-4536509
3-33	Multiplexing System Cable Diagram	401-4536535
3-34	AC Power Panel Schematic	302-4536557
3-35	24-VDC Computer Battery Box	P-S7-1055
3-36	Sphere Internal Arrangements	529-4420897
3-37	Master Power Panel Schematic	302-4536548
3-38	Power Distribution Schematic	302-4536550
3-39	Electrical and Electronic System Cabling and Connections	302-1705278
3-40	Interior Wire List	302-4536509
3-41	Internal AC and DC Power Distribution	302-4536561
3-42	Electrical and Electronic System Cabling and Connections	302-1705278
3-43	Interior Wire List	302-4536509
3-44	AC/DC Internal Power Distribution Cable Diagram	302-4536561
3-45	Ballast Control Panel Assembly	2234-42456
3-46	Low Voltage Detector Schematic	412-4536598
3-47	Yardney Electric High Detector Schematic	YEC E-87362-11671
3-48	Scanner Switch Wiring Diagram	YEC E-87362-11669
3-49	Propulsion Control Panel Schematic	Dwg DSV1-302-4536545
3-50	Propulsion System Cabling Diagram	Dwg DSV1-401-4536534
3-51	G. E. Propulsion Motor Mods	Dwg DSV1-302-2099279
3-52	Technical Information Manual, Propulsion Control Panel	

CHAPTER III - REFERENCE (Cont'd)

REFERENCE	TITLE	NUMBER
3-53	Multiplex System Cabling Diagram	DSV1-401-4536535
3-54	DSV-1 Lighting Patters	DSV1-303-4536517
3-55	Operation and Maintenance Manual for Gas Dis-charge Lamps, TRIESTE II (DSV-1), Hydro Products	
3-56	Operation and Maintenance Manual for Incandescent Lamps, TRIESTE II (DSV-1), Hydro Products	
3-57	Instruction Manual for Benthos 2000W Deep Sea Flash	
3-58	Navigation Lights Assembly and Detail	DSV1-400-4536573
3-59	Lighting Control Panel Technical Information Manual	
3-60	Lighting Control Panel Schematic	DSV1-303-4536546
3-61	Operation and Maintenance Manual for Ballast Unit, Multi-vapor 400W, TRIESTE II (DSV-1), Hydro Products	
3-62	Operation and Service Manual for Power Regulator Model SR-2000, Aerospace Avionics	
3-63	Schematic Lighting Contactor Bottle #1	DSV1-401-4536562
3-64	Schematic Lighting Contactor Bottle #2	DSV1-401-4536563
3-65	Operator's Manual for TRIESTE II Maintenance Trainer	
3-66	K 10,500 Trail Ball Winch and Cable Tension Sensor System for Bathyscaph -- TRIESTE II (DSV-1) Instrument and Control System.	
3-67	Ballast Dropping Gear and Foundations	121-1705243
3-68	External Wireways Installation Details and List of Material	302-1705266
3-69	Release Magnet Assembly and Details	508-2099262
3-70	Ballast Control Panel Assembly and Schematic	2234-42456

CHAPTER IV - REFERENCE

REFERENCE	TITLE	NUMBER
4-1	Mark 27, MOD. O Gyrocompass Equipment	NAVSHIPS 0924-007-5010
4-2	Operation-Maintenance Manual for Model 500 CTFM Scanning and Navigation Sonar	NAVSHIPS
4-3	Electrical and Electronic System Cabling and Connections	401-1705278
4-4	CTFM Sonar Switch Bottle Schematic	412-4536593
4-5	Hydro Products, Operation Instruction Manual, Model 404 Depth Sensor	
4-6	Hydro Products Co., Model 402 Depth Dock Module P. O. Box 10766 San Diego 10 California USA	
4-7	Transponder SET, Sonar, Homing AN/BQN-A	NAVSHIPS 0967-303-4010
4-8	Instruction Manual for Deep Sea Velocimeter- Model 1030-105 NUS Corporatin Underwater System Divison Paramus, New Jersey 07652	
4-9	Communications Panel 400AXT Schematic	4534998
4-10	Technical Manual, Communications Unit Model 400 AXT	
4-11	TV Camera Control Panel Schematic	DSV1-401-4536537
4-12	Pan and Tilt Control and Indicator Panel Schematic	DSV1-400-4536566
4-13	Operation and Maintenace Instructions Underwater Television Camera Model TC-125-T2, Hydro Products	
4-14	Operation and Maintenance Instructions Underwater Television Camera Model TC-150-MIL-ST- Z-T, Dillingham (Hydro Products)	
4-15	Operation and Maintenance Instructions Pan and Tilt Unit Model RP-3, Hydro Products	
4-16	Operation and Maintenance Manual for TRIESTE II (DSV-1) TV Synchronization Generator, Sperry SMD	

CHAPTER IV - REFERENCE (Cont'd)

REFERENCE	TITLE	NUMBER
4-17	Interim Instruction Manual T-II (DSV-1) Television Monitors, Westinghouse Electric Corporation Marine Operations Division T-II Support	
4-18	Sony Service Manual AV-3400 Videocorder	
4-19	Operation and Maintenance Instructions Deep Sea Photographic Camera Model PC-785, Hydro Products	
4-20	Operation and Maintenance Instructions Underwater Electronic Strobe Model PF-735	
4-21	Schematic Diagram Lighting Control Panel	DSV1-303-4536546
4-22	Technical Information Manual Lighting Control Panel	

CHAPTER V - REFERENCE

REFERENCE	TITLE	NUMBER
5-1	Technical Manual for Thermoelectric Environmental Control and Life Support System, Westinghouse Electric Corporation, Underseas Division	A42601RX1E - BA323
5-2	Oxygen System Diagram, Arrangement and Details	DSV1-553-4536560
5-3	Emergency Breathing System Mask Modules	DSV1-553-4421142

CHAPTER VI - REFERENCE

REFERENCE	TITLE	NUMBER
6-1	Valve Reach Rods and Mechanical Linkage	DSV1-516-1705282
6-2	ECT, and Access Trunk Flood and Drain System	DSV1-508-1520710
6-3	MBT, ECT and Access Trunk Blow and Vent System Piping Arrangement	DSV1-513-1520712
6-4	Equipment Dropping Gear Structure Modification and Details	DSV1-528-1705250
6-5	Ballast Dropping Gear and Fdn	DSV1-121-1705243
6-6	Hoist Winch Assy	934J155
6-7	T. M. for Trail Ball Winch and Cable Tension Sensor System	GB-14-1001 Sperry Publication
6-8	Volume 5 Part 2 FBM Developmental System External Control Mechanism (U) Manipulator System	

CHAPTER VII - REFERENCE

REFERENCE	TITLE	NUMBER
7-1	Handling and Tie Down Arrangements and Details	DSV1-601-2099264
7-2	Diagram Gasoline System	AGDS-2-542-4422732
7-3	Gas Pump and Service Room P/A and L/M	AGDS-2-542-4422734
7-4	Gas Pump and Service Room P/A and L/M	AGDS-2-542-4422735
7-5	Diagram, N ₂ System	AGDS-2-553-4422727
7-6	N ₂ System Piping Arrangement	AGDS-2-553-4422728
7-7	N ₂ System B/M	AGDS-2-553-4435734
7-8	Power System Modifications Incidental to Accomplishment of SHIPALTS AGDS-1 and AGDS-2	AGDS-2-302-4536351
7-9	Procurement Specification, Battery Charging Cables	DSV1-302-4536572
7-10	Tender Charging Facilities Mods	T11 302-1705275
7-11	Battery Monitoring System Wiring Diagram	DSV1-302-1520706